

# METROPOLITAN COAL LONGWALLS 305-307

## BUILT FEATURES MANAGEMENT PLAN



## METROPOLITAN COAL

### LONGWALL 305-307

## BUILT FEATURES MANAGEMENT PLAN

### Transport for NSW

ME-TSE-MNP-0088

#### Revision Status Register

Section/Page/ Annexure	Revision Number	Amendment/Addition	Distribution	DPE Approval Date
All	LW305-307 BFMP_RMS-R01-A	Original	DPIE, RMS (Technical Committee)	-
	LW305-307 BFMP_RMS-R01-B	Revision to address minor comments from RMS	DPIE, RMS (Technical Committee)	16 March 2020
All	LW305-307 BFMP_RMS-R01-C	Updated to reflect 50 m extension of Longwall 307	DPIE	13 August 2021
All	LW305-307 BFMP_TfNSW-R01-D	Update to incorporate entity change RMS to TfNSW & monitoring arrangements for LW306 & LW307	DPE, TfNSW (Technical Committee)	

February 2022

**AUTHORISATION OF MANAGEMENT PLAN**

**Authorised on behalf of TfNSW**

**Authorised on behalf of Metropolitan Coal**

**Original BFMP LW305-307 authorised by Martin Cocca**

**Changes Recommended for Revision D by:**

Technical Committee,

.....

Date : .....

**Changes Approved by**

Cyril Gunaratne

Jon Degotardi

Position: Pavement Maintenance Planner,  
Southern Region

Technical Services Manager

.....

.....

Date : .....

Date : .....

Metropolitan Coal – LW305 - 307 Built Features Management Plan – Transport for NSW		
Revision No. BFMP_TfNSW-R01-D	ME-TSE-MNP-0088	i
Document ID: Built Features Management Plan – TfNSW		

## TABLE OF CONTENTS

1	INTRODUCTION	5
	1.1 PURPOSE AND SCOPE	5
	1.2 STRUCTURE OF THE BFMP-TFNSW	11
2	BFMP-TFNSW REVIEW AND UPDATE	12
	2.1 DISTRIBUTION REGISTER	12
3	STATUTORY REQUIREMENTS	13
	3.1 EP&A ACT APPROVAL	13
	3.2 LICENCES, PERMITS AND LEASES	15
	3.3 OTHER LEGISLATION	15
4	REVISED ASSESSMENT OF POTENTIAL ENVIRONMENTAL CONSEQUENCES	16
	4.1 EXTRACTION LAYOUT	16
	4.2 OVERVIEW – SUBSIDENCE PREDICTIONS AND IMPACT ASSESSMENTS	16
	4.2.1 Risk Assessment	19
	4.3 BRIDGE 1 – OLD PRINCES HIGHWAY UNDERPASS (SOUTHERN)	20
	4.4 BRIDGE 2 – OLD PRINCES HIGHWAY UNDERPASS	20
	4.5 CAWLEY ROAD OVERBRIDGE	21
	4.6 CARRIAGEWAY	21
	4.7 CULVERTS AND DRAINAGE STRUCTURES	22
	4.8 M1 PRINCES MOTORWAY CUTTINGS	22
	4.9 VARIABLE MESSAGE SIGN STRUCTURES AND ROADSIDE FURNITURE	23
5	PERFORMANCE MEASURES AND INDICATORS	23
	5.1 PERFORMANCE MEASURES	23
	5.2 PERFORMANCE INDICATORS	23
	5.2.1 Bridge Distortion and Cracking	24
	5.2.2 M1 Princes Motorway Pavement Deformation	24
	5.2.3 Cuttings and Faults	25
	5.2.4 Culverts	25
6	BASELINE DATA	25
	6.1 GENERAL	25
	6.2 BRIDGE 2 – OLD PRINCES HIGHWAY UNDERPASS	25
	6.3 CAWLEY ROAD OVERBRIDGE	25
	6.4 M1 PRINCES MOTORWAY PAVEMENT	26
	6.5 CUTTINGS	26
	6.6 CULVERTS	26
	6.7 GROUND MONITORING	28
7	MONITORING	28
	7.1 GENERAL	28
	7.2 BRIDGE MONITORING METHODS	28
	7.3 MONITORING OF BRIDGE 2 – OLD PRINCES HIGHWAY UNDERPASS	30
	7.3.1 Relative 3D Survey	30
	7.3.2 FBG Sensor Measurements	34
	7.3.3 Survey Frequency	36
	7.3.4 FBG Monitoring Frequency	36
	7.3.5 Visual Inspections	37
	7.4 MONITORING OF CAWLEY ROAD OVERBRIDGE	37
	7.4.1 Relative 3D Survey	37
	7.4.2 Survey Frequency	37
	7.4.3 Visual Inspections	38
	7.5 ROAD WORKS	38

	7.5.1	Ground Monitoring	38
	7.5.2	TFNSW Road Mounted Monitoring Systems and Visual Monitoring	38
	7.5.3	Cuttings	38
	7.5.4	Culverts	39
7.6		MONITORING PROGRAM	39
7.7		SUBSIDENCE PARAMETERS	44
	7.7.1	Ground Monitoring	44
	7.7.2	Bridge Monitoring	44
7.8		SUBSIDENCE IMPACTS	45
	7.8.1	Bridge Impacts	45
	7.8.2	Pavement Impacts	46
	7.8.3	Impacts to Cuttings	46
	7.8.4	Impacts to Culverts	46
7.9		ENVIRONMENTAL CONSEQUENCES	46
8		MANAGEMENT MEASURES	47
	8.1	GENERAL	47
	8.2	BRIDGES	47
	8.3	ROAD PAVEMENTS	47
	8.4	CUTTINGS	47
	8.5	CULVERTS	48
9		CONTINGENCY PLAN	48
	9.1	CONTINGENCY MEASURES	49
10		TARP – MANAGEMENT TOOL	50
11		FUTURE EXTRACTION PLANS	66
12		ANNUAL REVIEW AND IMPROVEMENT OF ENVIRONMENTAL PERFORMANCE	66
13		INCIDENTS	67
14		COMPLAINTS	67
15		NON-COMPLIANCE WITH STATUTORY REQUIREMENTS	68
16		REFERENCES	69

## LIST OF TABLES

Table 1	Technical Committee
Table 2	Management Plan Requirements
Table 3	Provisional Extraction Schedule
Table 4	Summary of Bridge 2 and Cawley Road Overbridge Details along the M1 Princes Motorway
Table 5	Incremental Relative Opening, Closing and Mid-Ordinate Deviation at Approximately 1,020 Metres Distance from the Active Longwall 305
Table 6	Incremental Relative Opening, Closing and Mid-Ordinate Deviation at Approximately 1.67 Kilometres Distance from the Active Longwall 305
Table 7	TFNSW Rock Cutting Details

Metropolitan Coal – LW305 - 307 Built Features Management Plan – Transport for NSW		
Revision No. BFMP_TfNSW-R01-D	ME-TSE-MNP-0088	Page ii
Document ID: Built Features Management Plan - TfNSW		

Table 8	Bridge 2 - 3D Survey Monitoring Locations
Table 9	BFMP-TFNSW Monitoring Program Overview
Table 10	Contingency Measures – TFNSW Assets
Table 11	Trigger Action Response Plan – Bridge 2 (Old Princes Highway Underpass)
Table 12	Trigger Action Response Plan – Cawley Road Overpass
Table 13	Trigger Action Response Plan – Pavement
Table 14	Trigger Action Response Plan – Cuttings
Table 15	Trigger Action Response Plan – Culverts

## LIST OF FIGURES

Figure 1	Longwalls 305-307 and Project Underground Mining Area
Figure 2	Longwalls 305-307 Layout
Figure 3	Longwalls 305-307 and Project Underground Mining Area – Aerial Photograph
Figure 4	Environmental Management Structure
Figure 5	Roads and Maritime Services Assets
Figure 6	Subsidence Monitoring Layout
Figure 7	Bridge 2 - Column and Blade Wall Plan View
Figure 8	Bridge 2 - Abutment A – Relative 3D Monitoring Locations
Figure 9	Bridge 2 - Abutment B – Relative 3D Monitoring Locations
Figure 10	Bridge 2 - Pier 1 – Relative 3D Monitoring Locations
Figure 11	Bridge 2 - Pier 2 – Relative 3D Monitoring Locations
Figure 12	Bridge 2 - Deck Girders – Elevation 1 – Relative 3D Monitoring Locations
Figure 13	Bridge 2 - Deck Girders – Elevation 2 – Relative 3D Monitoring Locations
Figure 14	Bridge 2 - Deck Girders – Elevation 3 – Relative 3D Monitoring Locations
Figure 15	Bridge 2 - Deck Girders – Elevation 4 – Relative 3D Monitoring Locations
Figure 16	Bridge 2 - FBG Sensor Layout – Abutment and Pier Headstocks
Figure 17	Bridge 2 - FBG Tiltmeter Layout – Pier Columns
Figure 18	Cawley Road Overbridge – Survey Monitoring Points

## LIST OF APPENDICES

Appendix 1	MSEC (2016) Metropolitan Colliery - Proposed Longwalls 301 to 303 - Subsidence Predictions and Impact Assessments for the Roads and Maritime Services Infrastructure, dated 6 September 2016
Appendix 2	MSEC (2019) Metropolitan Colliery - Proposed Longwall 304 - Subsidence Predictions and Impact Assessments for the Roads and Maritime Services Infrastructure
Appendix 3	MSEC (2019) Metropolitan Colliery - Proposed Longwalls 305-307 - Subsidence Predictions and Impact Assessments for the Roads and Maritime Services Infrastructure

Metropolitan Coal – LW305 - 307 Built Features Management Plan – Transport for NSW		
Revision No. BFMP_TfNSW-R01-D	ME-TSE-MNP-0088	Page iii
Document ID: Built Features Management Plan - TfNSW		

Appendix 4	Glossary of Terms TfNSW and Definitions
Appendix 5	Metropolitan Colliery Longwall Mining - LW301-303 Risk Assessment as Applied to RMS Assets
Appendix 6	Metropolitan Colliery Longwall Mining - LW304-306 Risk Assessment as Applied to RMS Assets
Appendix 7	Metropolitan Colliery Longwall Mining - LW305-307 Risk Assessment as Applied to RMS Assets
Appendix 8	Built Features Management Plan - Subsidence Impact Register
Appendix 9	Contingency Plan Procedure and Decision Trees
Appendix 10	AECOM Memorandum – Metropolitan Coal LW304 Bridge 2 Trigger Review

## 1 INTRODUCTION

The Metropolitan Coal Mine is owned and operated by Metropolitan Coal Pty Ltd (Metropolitan Coal), which is a wholly owned subsidiary of Peabody Energy Australia Pty Ltd (Peabody). The Metropolitan Coal Mine is located adjacent to the township of Helensburgh, approximately 30 kilometres (km) north of Wollongong in New South Wales (NSW) (Figure 1).

Metropolitan Coal was granted approval for the Metropolitan Coal Project (the Project) under section 75J of the New South Wales (NSW) *Environmental Planning and Assessment Act 1979* (EP&A Act) on 22 June 2009. A copy of the Project Approval is available on the Peabody website (<http://www.peabodyenergy.com>).

The Project comprises the continuation, upgrade and extension of underground coal mining operations (Longwalls 20-27 and Longwalls 301-317) and surface facilities at Metropolitan Coal. Longwalls 305-307 are situated to the west of Longwalls 301-304 and define the next mining sub-domain within the Project underground mining area (Figures 1 to 3). Longwall 311 on will be subject to future Extraction Plans.

### 1.1 PURPOSE AND SCOPE

In accordance with Condition 6(f), Schedule 3 of the Project Approval, this Built Features Management Plan – Transport for NSW (BFMP-TfNSW) has been developed to manage the potential consequences of Longwalls 305-307 extraction on the TfNSW assets.

The relationship of this BFMP-TfNSW to the Metropolitan Coal Environmental Management Structure is shown on Figure 4.

This BFMP-TfNSW includes post-mining monitoring and management of TfNSW assets subject to the previously approved Metropolitan Coal Longwall 304 Extraction Plan.

The TfNSW assets to which this BFMP-TfNSW applies are shown in Figure 5. These include:

- Bridge works:
  - bridge structures (TfNSW reference BN616-southbound and BN617-northbound) at the Old Princes Highway Underpass [referred to herein as 'Bridge 2'], located approximately 1,020 metres (m) south-east of Longwall 305; and
  - bridge structures (TfNSW reference BN615) at the Cawley Road<sup>1</sup> Overbridge, located approximately 1.67 kilometres (km) north-east of Longwall 305.
- Road works:
  - carriageway pavement, located from approximately 1,040 m east of the southern end of Longwall 305 to 1.1 km east of the northern end of Longwall 305;
  - cuttings (TfNSW slope numbers: 10425, 10426, 10427, 10428, 13560, 13561, 13562 and 13563) up to maximum height of 20 m;
  - embankments;
  - drainage and drainage structures (including kerbs, gutters, pits and culverts with pipes of varying diameters from 375 millimetres (mm) to 1,800 mm); and
  - TfNSW roadside furniture.

<sup>1</sup> Also referred as Cawleys Road.

Metropolitan Coal –305 - 307 Built Features Management Plan – Transport for NSW		
Revision No. BFMP_TfNSW-R01-D	ME-TSE-MNP-0088	Page 5
Document ID: Built Features Management Plan - TfNSW		

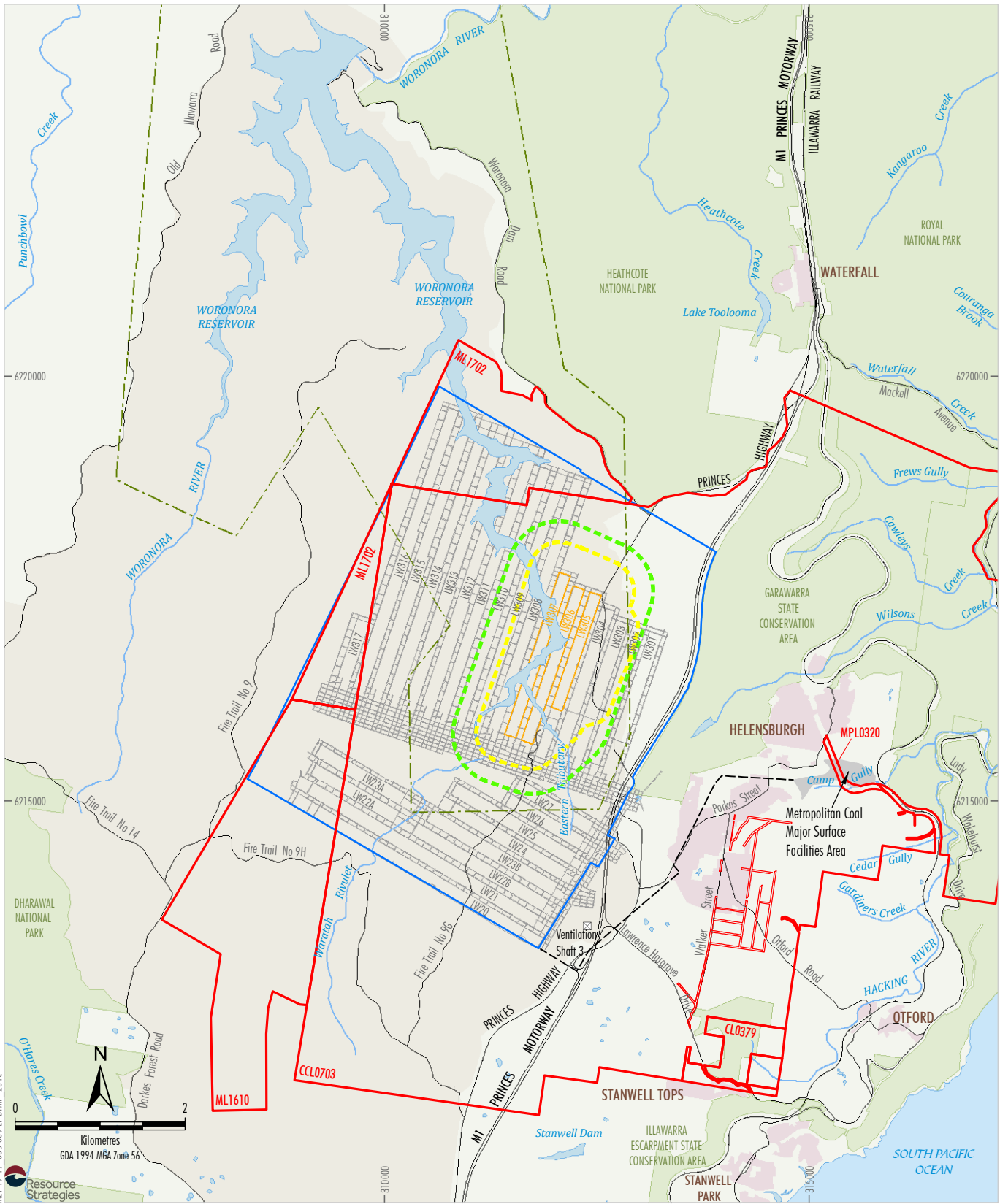

- LEGEND**
- Mining Lease Boundary
  - Woronora Special Area
  - Railway
  - Project Underground Mining Area  
Longwalls 20-27 and 301-317
  - Longwalls 305-307 Secondary Extraction
  - Longwalls 305-307 35° Angle of Draw and/or  
Predicted 20 mm Subsidence Contour
  - 600 m from Longwalls 305-307  
Secondary Extraction
  - Woronora Notification Area
  - Existing Underground Access Drive (Main Drift)

Source: Land and Property Information (2015); Department of Industry (2015); Metropolitan Coal (2019); MSEC (2019)

**Peabody**  
METROPOLITAN COAL  
Longwalls 305-307 and  
Project Underground Mining Area

**Figure 1**

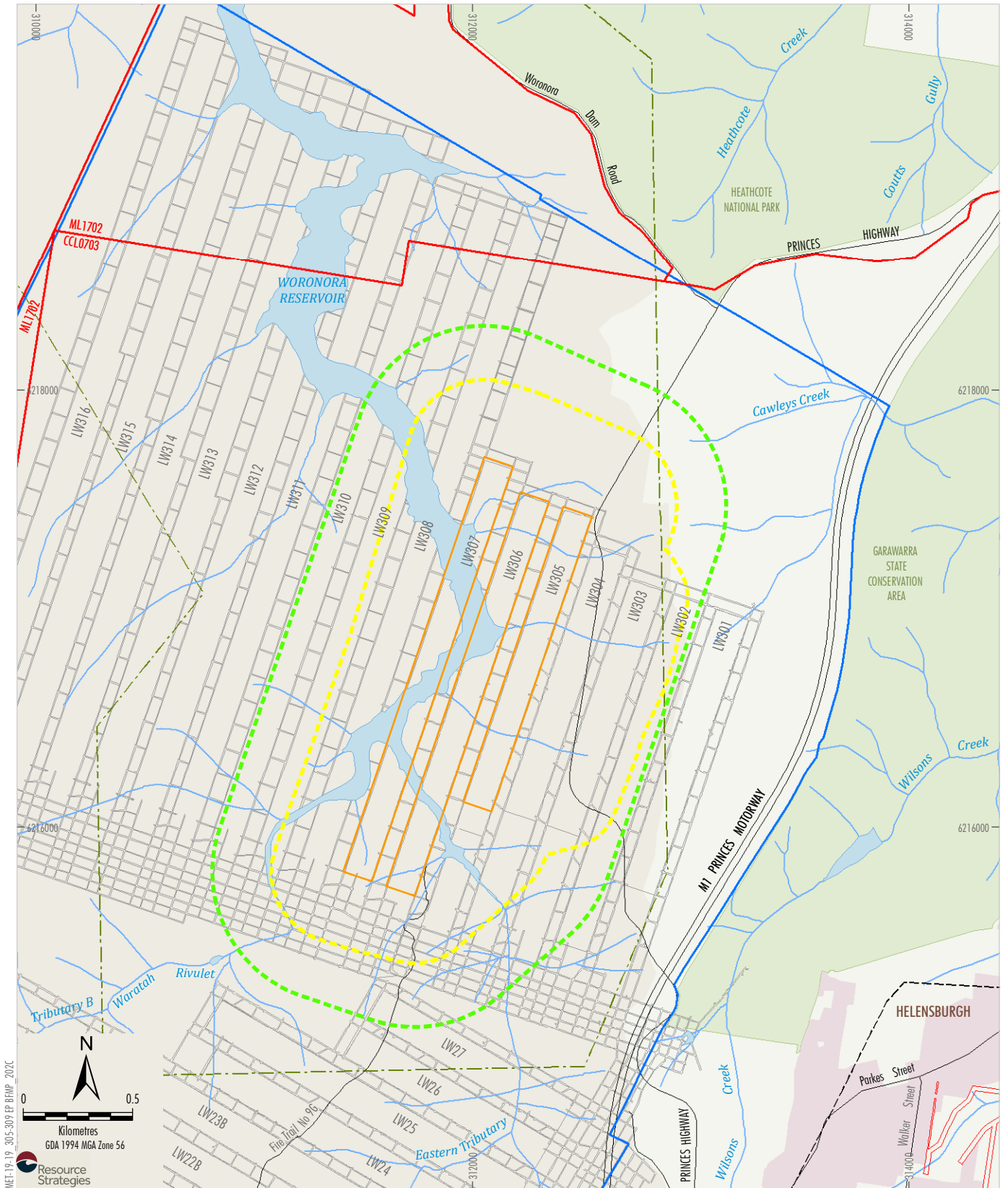

ME1-19-305-307 EP BFMP 2020  
 Resource Strategies

**LEGEND**

- Mining Lease Boundary
- Woronora Special Area
- Project Underground Mining Area  
Longwalls 20-27 and 301-317
- Longwalls 305-307 Secondary Extraction
- Longwalls 305-307 35° Angle of Draw and/or  
Predicted 20 mm Subsidence Contour
- 600 m from Longwalls 305-307  
Secondary Extraction
- Woronora Notification Area
- Existing Underground Access Drive (Main Drift)

Source: Land and Property Information (2015); Department of Industry (2015);  
 Metropolitan Coal (2019); MSEC (2019)

**Peabody**  
 METROPOLITAN COAL  
 Longwalls 305-307 Layout

**Figure 2**

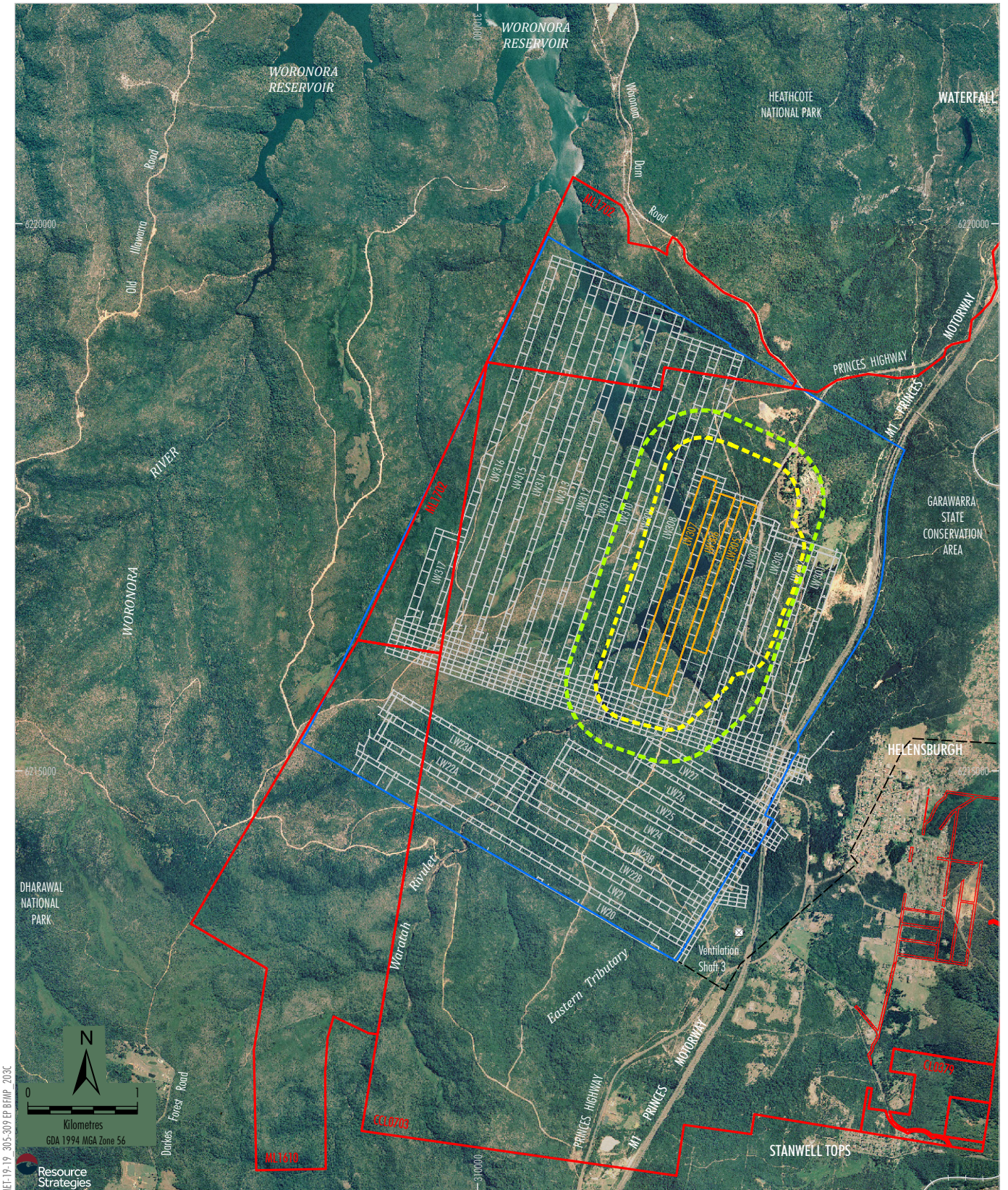

- LEGEND**
- Mining Lease Boundary
  - Railway
  - Project Underground Mining Area  
Longwalls 20-27 and 301-317
  - Longwalls 305-307 Secondary Extraction
  - Longwalls 305-307 35° Angle of Draw and/or  
Predicted 20 mm Subsidence Contour
  - 600 m from Longwalls 305-307  
Secondary Extraction
  - Existing Underground Access Drive (Main Drift)

Source: Land and Property Information (2015); Date of Aerial Photography 1998;  
Department of Industry (2015); Metropolitan Coal (2019); MSEC (2019)

**Peabody**  
METROPOLITAN COAL  
Longwalls 305-307 and  
Project Underground Mining Area-  
Aerial Photograph

**Figure 3**

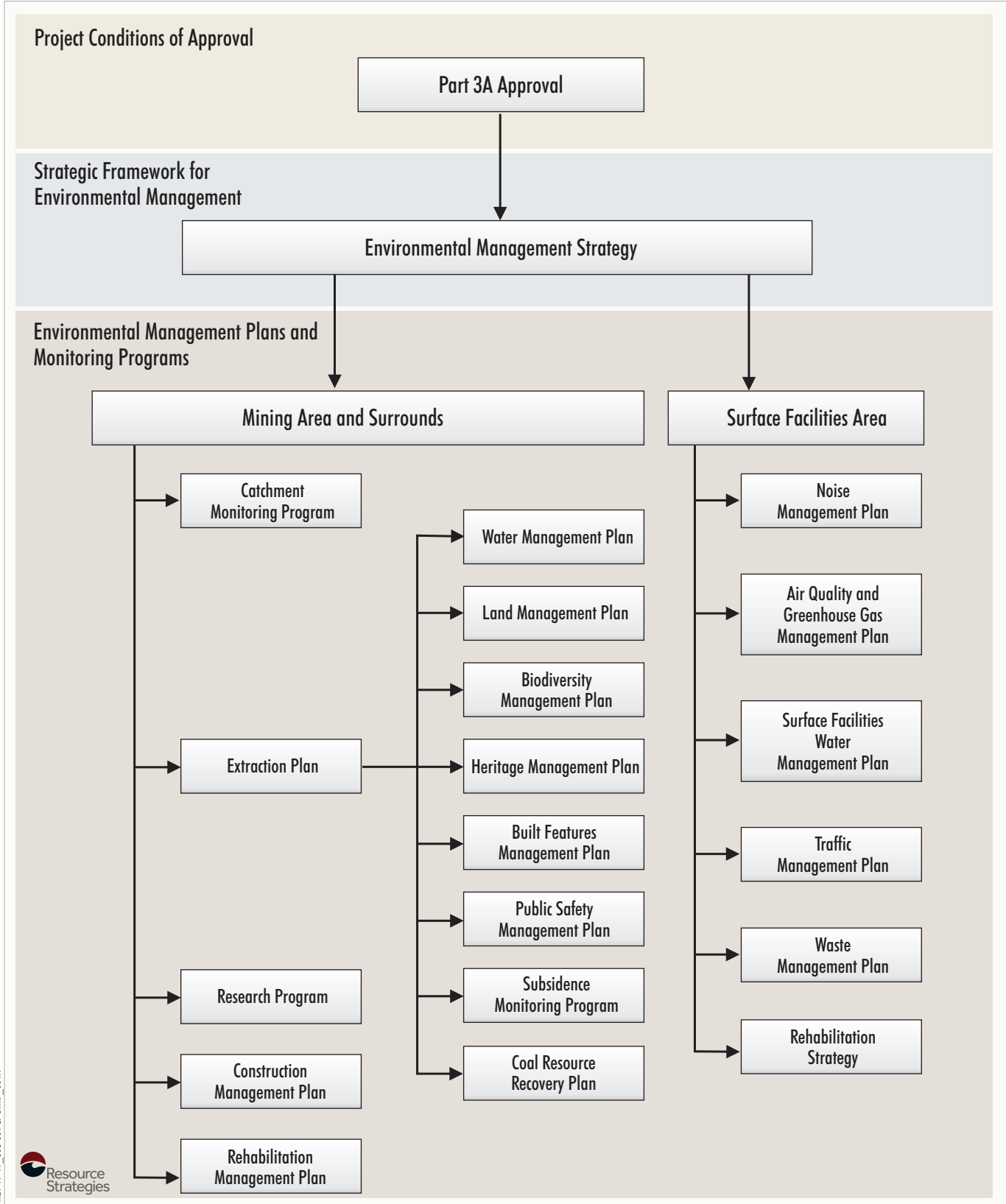

ME1-19\_305-309 EP BRMP\_001A



Figure 4



In accordance with Condition 6, Schedule 3 of the Project Approval, the suitably qualified and experienced experts that have managed the preparation of this BFMP-TFNSW, namely representatives from Mine Subsidence Engineering Consultants (MSEC) and Metropolitan Coal were endorsed by the Secretary of the Department of Planning and Environment (DP&E) (now the NSW Department of Planning and Environment<sup>2</sup> [DPE]).

This BFMP-TFNSW has been prepared with the assistance of a Technical Committee (TC) comprising representatives of the TFNSW and Metropolitan Coal together with technical specialists, AECOM, Cardno and MSEC as nominated in Table 1. This BFMP-TFNSW has been endorsed by each TC member in their area of expertise.

**Table 1**  
**Technical Committee**

<b>Organisation</b>	<b>Member</b>
TFNSW (Project Manager)	Dick Lee Shoy
TFNSW (Maintenance Planners)	Cyril Gunaratne, Dony Castro
Metropolitan Coal – Primary Contact	Jon Degotardi
Mine Subsidence Engineering Consultants (MSEC)	Peter DeBono
AECOM (Technical Director)	Henk Buys
Cardno (Senior Principal Bridges)	Richard Woods
NSW Police	May attend as Observer
Subsidence Advisory NSW	Matthew Montgomery

## 1.2 STRUCTURE OF THE BFMP-TFNSW

The remainder of the BFMP-TFNSW is structured as follows:

- Section 2: Describes the review and update of the BFMP-TFNSW.
- Section 3: Outlines the statutory requirements applicable to the BFMP-TFNSW.
- Section 4: Provides a revised assessment of the potential subsidence impacts and environmental consequences for Longwalls 305-307.
- Section 5: Details the performance measures and indicators that will be used to assess the Project.
- Section 6: Provides the detailed baseline data.
- Section 7: Describes the monitoring program.
- Section 8: Describes the management measures that will be implemented.
- Section 9: Provides a contingency plan to manage any unpredicted impacts and their consequences.
- Section 10: Describes the Trigger Action Response Plan (TARP) management tool.
- Section 11: Describes the program to collect sufficient baseline data for future Extraction Plans.
- Section 12: Describes the annual review and improvement of environmental performance.

<sup>2</sup> The former Department of Planning, Industry and Environment (DPIE) was renamed to the Department of Planning and Environment (DPE) on 21 December 2021. References to DPIE have been retained throughout the remainder of this document.

- Section 13: Outlines the management and reporting of incidents.
- Section 14: Outlines the management and reporting of complaints.
- Section 15: Outlines the management and reporting of non-compliances with statutory requirements.
- Section 16: Lists the references cited in this BFMP-TFNSW.

## 2 BFMP-TFNSW REVIEW AND UPDATE

In accordance with Condition 4, Schedule 7 of the Project Approval, BFMP-TFNSW will be reviewed within three months of the submission of:

- an audit under Condition 8, Schedule 7;
- an incident report under Condition 6, Schedule 7;
- an annual review under Condition 3, Schedule 7; and
- if necessary, revised to the satisfaction of the Director-General (now Secretary) of the DPIE, to ensure the plan is updated on a regular basis and to incorporate any recommended measures to improve environmental performance.

This BFMP will also be reviewed within three months of approval of any Project modification and if necessary, revised to the satisfaction of the DPIE.

The revision status of this plan is indicated on the title page of each copy of the BFMP-TFNSW. The distribution register for controlled copies of the BFMP-TFNSW is described in Section 2.1.

Revisions to any documents listed within this BFMP-TFNSW will not necessarily constitute a revision of this document.

### 2.1 DISTRIBUTION REGISTER

In accordance with Condition 10, Schedule 7 'Access to Information', Metropolitan Coal will make the BFMP-TFNSW publicly available on the Peabody website. A hard copy of the BFMP-TFNSW will also be maintained at the Metropolitan Coal site.

Metropolitan Coal recognises that various regulators have different distribution requirements, both in relation to whom documents should be sent and in what format. An Environmental Management Plan and Monitoring Program Distribution Register has been established in consultation with the relevant agencies and infrastructure owners that indicates:

- to whom the Metropolitan Coal plans and programs, such as the BFMP-TFNSW, will be distributed;
- the format (i.e. electronic or hard copy) of distribution; and
- the format of revision notification.

Metropolitan Coal will make the Distribution Register publicly available on the Peabody website.

Metropolitan Coal will be responsible for maintaining the Distribution Register and for ensuring that the notification of revisions is sent by email or post as appropriate.

Metropolitan Coal –305 - 307 Built Features Management Plan – Transport for NSW		
Revision No. BFMP_TFNSW-R01-D	ME-TSE-MNP-0088	Page 12
Document ID: Built Features Management Plan - TfNSW		

In addition, Metropolitan Coal employees with local computer network access will be able to view the controlled electronic version of this BFMP-TFNSW on the Metropolitan Coal local area network. Metropolitan Coal will be responsible for maintaining controlled copies, ensuring the most recent version is maintained on Metropolitan Coal’s computer system and the Peabody website.

### 3 STATUTORY REQUIREMENTS

Metropolitan Coal’s statutory obligations are contained in:

- (i) the conditions of the Project Approval;
- (ii) relevant licences and permits, including conditions attached to mining leases; and
- (iii) other relevant legislation.

These are described below.

#### 3.1 EP&A ACT APPROVAL

Condition 6(f), Schedule 3 of the Project Approval requires the preparation of a BFMP as a component of Extraction Plan(s) for second workings. Project Approval Condition 6(f), Schedule 3 states:

**SECOND WORKINGS**

**Extraction Plan**

6. *The Proponent shall prepare and implement an Extraction Plan for all second workings in the mining area to the satisfaction of the Director-General. This plan must:*

...

(f) *include a:*

...

- *Built Features Management Plan, which has been prepared in consultation with the owner of the relevant feature, to manage the potential environmental consequences of the Extraction Plan on any built features;*

...

In addition, Condition 2, Schedule 7 and Condition 7, Schedule 3 of the Project Approval outline management plan requirements that are applicable to the preparation of the BFMP-TFNSW. Table 2 indicates where each component of the conditions is addressed within this BFMP-TFNSW.

**Table 2  
Management Plan Requirements**

Project Approval Condition	BFMP-TFNSW Section
<p><b>Condition 2 of Schedule 7</b></p> <p>2. The Proponent shall ensure that the management plans required under this approval are prepared in accordance with any relevant guidelines, and include:</p> <p>a) detailed baseline data;</p> <p>b) a description of:</p> <ul style="list-style-type: none"> <li>• the relevant statutory requirements (including any relevant approval, licence or lease conditions);</li> <li>• any relevant limits or performance measures/criteria;</li> <li>• the specific performance indicators that are proposed to be used to judge the performance of, or guide the implementation of, the project or any management measures;</li> </ul> <p>c) a description of the measures that would be implemented to comply with the relevant statutory requirements, limits, or performance measures/criteria;</p> <p>d) a program to monitor and report on the:</p> <ul style="list-style-type: none"> <li>• impacts and environmental performance of the project;</li> <li>• effectiveness of any management measures (see c above);</li> </ul> <p>e) a contingency plan to manage any unpredicted impacts and their consequences;</p> <p>f) a program to investigate and implement ways to improve the environmental performance of the project over time;</p> <p>g) a protocol for managing and reporting any:</p> <ul style="list-style-type: none"> <li>• incidents;</li> <li>• complaints;</li> <li>• non-compliances with statutory requirements; and</li> <li>• exceedances of the impact assessment criteria and/or performance criteria; and</li> </ul> <p>h) a protocol for periodic review of the plan.</p>	<p align="center">Section 6</p> <p align="center">Section 3</p> <p align="center">Section 5 Section 5.2</p> <p align="center">Sections 7, 8, 9 and 10</p> <p align="center">Sections 7, 8 and 12</p> <p align="center">Section 9 and Appendix 9</p> <p align="center">Sections 7 and 12</p> <p align="center">Section 13</p> <p align="center">Section 14</p> <p align="center">Section 15</p> <p align="center">Section 9 and Appendix 9</p> <p align="center">Section 2</p>
<p><b>Condition 7 of Schedule 3</b></p> <p>7. In addition to the standard requirements for management plans (see condition 2 of schedule 7), the Proponent shall ensure that the management plans required under condition 6(f) above include:</p> <p>a) a program to collect sufficient baseline data for future Extraction Plans;</p> <p>b) a revised assessment of the potential environmental consequences of the Extraction Plan, incorporating any relevant information that has been obtained since this approval;</p> <p>c) a detailed description of the measures that would be implemented to remediate predicted impacts; and</p> <p>d) a contingency plan that expressly provides for adaptive management.</p>	<p align="center">Section 11</p> <p align="center">Section 4</p> <p align="center">Section 8</p> <p align="center">Section 9 and Appendix 9</p>

### 3.2 LICENCES, PERMITS AND LEASES

In addition to the Project Approval, all activities at or in association with Metropolitan Coal will be undertaken in accordance with the following licences, permits and leases which have been issued or are pending issue:

- The conditions of mining leases issued by the NSW Division of Resources and Geoscience (DRG) (now Mining, Exploration and Geoscience [MEG]), under the NSW *Mining Act 1992* (e.g. Consolidated Coal Lease [CCL] 703, Mining Lease [ML] 1610, ML 1702, Coal Lease [CL] 379 and Mining Purpose Lease 320).
- The *Metropolitan Coal Mining Operations Plan 1 October 2021 to 30 September 2023* approved by the Resources Regulator.
- The conditions of Environment Protection Licence (EPL) No. 767 issued by the NSW Environment Protection Authority (EPA) under the NSW Protection of the Environment Operations Act 1997. Revision of the EPL will be required prior to the commencement of Metropolitan Coal activities that differ from those currently licensed.
- The prescribed conditions of specific surface access leases within CCL 703 for the installation of surface facilities as required.
- Water Access Licences (WALs) issued by the NSW Department of Industry – Water (now DPIE – Water) under the NSW *Water Management Act 2000*, including WAL 36475 under the *Water Sharing Plan for the Greater Metropolitan Region Groundwater Sources 2011* and WAL 25410 under the *Water Sharing Plan for the Greater Metropolitan Region Unregulated River Water Sources 2011*.
- Mining and workplace health and safety related approvals granted by the Resources Regulator and WorkCover NSW.
- Supplementary approvals obtained from WaterNSW for surface activities within the Woronora Special Area (e.g. fire road maintenance activities).

### 3.3 OTHER LEGISLATION

Metropolitan Coal will conduct the Project consistent with the Project Approval and any other legislation that is applicable to an approved Part 3A Project under the EP&A Act.

The following Acts may be applicable to the conduct of the Project (Helensburgh Coal Pty Ltd [HCPL], 2008)<sup>3</sup>:

- *Biodiversity Conservation Act 2016*;
- *Biosecurity Act 2015*;
- *Contaminated Land Management Act 1997*;
- *Crown Land Management Act 2016*;
- *Dams Safety Act 1978*;
- *Dangerous Goods (Road and Rail Transport) Act 2008*;
- *Energy and Utilities Administration Act 1987*;

<sup>3</sup> The list of potentially applicable Acts has been updated to reflect changes to the Acts that were in force at the time of submission of the Metropolitan Coal Project Environmental Assessment (Project EA) (HCPL, 2008).

Metropolitan Coal –305 - 307 Built Features Management Plan – Transport for NSW		
Revision No. BFMP_TFNSW-R01-D	ME-TSE-MNP-0088	Page 15
Document ID: Built Features Management Plan - TfNSW		

- *Fisheries Management Act 1994;*
- *Mining Act 1992;*
- *Protection of the Environment Operations Act 1997;*
- *Rail Safety (Adoption of National Law) Act 2012;*
- *Roads Act 1993;*
- *Water Act 1912;*
- *Water Management Act 2000;*
- *Water NSW Act 2014;*
- *Work Health and Safety Act 2011; and*
- *Work Health and Safety (Mines and Petroleum Sites) Act 2013.*

Relevant licences or approvals required under these Acts will be obtained as required.

## 4 REVISED ASSESSMENT OF POTENTIAL ENVIRONMENTAL CONSEQUENCES

### 4.1 EXTRACTION LAYOUT

Longwalls 305-307 and the area of land within 600 m of Longwalls 305-307 secondary extraction are shown on Figures 1 and 2. Longwall extraction occurs from north to south. The Longwall 305 layout includes a 138 m panel width (void), a 45 m tailgate pillar width and a 70 m main gate pillar width. The longwall layout of Longwalls 306 and 307 includes 138 m panel widths (void) and 70 m pillars (solid). The provisional extraction schedule for Longwalls 305-307 is provided in Table 3.

**Table 3**  
**Provisional Extraction Schedule**

Longwall	Estimated Start Date	Estimated Duration	Estimated Completion Date
Longwall 305	April 2020	8 Months	November 2020
Longwall 306	June 2021	11 Months	April 2022
Longwall 307	May 2022	9 Months	January 2023

The future Extraction Plans will consider the cumulative subsidence effects, subsidence impacts and/or environmental consequences. Note that the total cumulative predicted subsidence effects, subsidence impacts and/or environmental consequences at the completion of the Project are considered in the Metropolitan Coal Project EA (Project EA) (HCPL, 2008) and the Preferred Project Report (HCPL, 2009).

### 4.2 OVERVIEW – SUBSIDENCE PREDICTIONS AND IMPACT ASSESSMENTS

The TFNSW assets relevant to the extraction of Longwalls 305-307 are illustrated in Figure 5. The revised predicted subsidence movements due to Longwalls 305-307 have been provided by MSEC (2019) (Appendix 3) and are summarised below.

The M1 Princes Motorway is located to the east of Longwall 305 and will not be directly mined beneath by Longwalls 305-307. The nearest point from the Longwalls 305-307 to the M1 Princes Motorway is approximately 1,040 metres (m) from finishing end of Longwall 305. A series of cuttings and embankments up to a maximum height of approximately 20 m are also located along the M1 Princes Motorway. There are a number of culverts that cross the M1 Princes Motorway, east of the Study Area. In addition to the culverts, there are also a number of other drainage structures, such as kerbs, gutters, pits and drainage pipes.

Bridge 2 (where a program of high accuracy monitoring has been implemented by the Technical Committee) is located approximately 1,020 m from Longwall 305.

Cawley Road Overbridge is located 1.67 km from the northern end of Longwall 305.

At over 1,020 m from Longwalls 305-307, the TFNSW assets are located outside of the Study Area and are not expected to experience measurable conventional vertical subsidence, tilts, curvatures or strains (i.e. less than the expected limits of survey accuracy) (MSEC, 2019).

There is, however, the potential for low level far-field horizontal movements (up to 40 mm at distances greater than 1,020 m, based on a 95% confidence level from a database of observed far-field horizontal movements in the Southern Coalfield) and non-conventional movements to occur at the TFNSW built features. It is noted that these low-level movements comprise a large portion of expected survey accuracy.

A drainage line crosses beneath the M1 Princes Motorway approximately 1,020 m to the east of the finishing end of Longwall 305. A second drainage line is located approximately 1,350 m from Longwall 305 to the north. At these distances, the culverts are not predicted to experience valley related movements, with movements less than the expected limits of survey accuracy.

Valley closure is not expected to occur in the cuttings along the M1 Princes Motorway, however, minor closure movements could be observed due to potential horizontal movements.

The features along the M1 Princes Motorway considered to be most sensitive to relative movements arising from far-field effects are Bridge 2 (at the location where the Old Princes Highway passes below the M1 Princes Motorway) and Cawley Road Overbridge.

Details of Bridge 2 are provided in Table 4. Based on far-field horizontal movement data, the predicted incremental relative opening and closing and mid ordinate deviation have been used to assess differential horizontal movement of the ground at Bridge 2 and their respective probabilities of exceedance are provided in Table 5.

For Bridge 2, the predicted incremental relative open or closing movement at a 1 in 2,000 probability is 20 mm and 21 mm, respectively and the predicted mid-ordinate deviation is 18 mm.

Metropolitan Coal – 305 - 307 Built Features Management Plan – Transport for NSW		
Revision No. BFMP_TFNSW-R01-D	ME-TSE-MNP-0088	Page 17
Document ID: Built Features Management Plan - TfNSW		

**Table 4**  
**Summary of Bridge 2 and Cawley Road Overbridge Details along the M1 Princes Motorway**

Bridge Name	TFNSW Name	TFNSW Chainage from Sydney	Nearest Longwall	Approximate Distance to nearest longwall (m)
Old Princes Highway Underpass 2 (Bridge 2)	Twin Bridges over Old Princes Highway BN616 on S/B carriageway BN617 on N/B carriageway	30 miles 1,326 feet (48 km 684.5 m)	301	330
Cawley Road Overbridge	BN615	28 miles 1,350 feet (45.47 km south of Sydney)	301	1,430

**Table 5**  
**Incremental Relative Opening, Closing and Mid-Ordinate Deviation at Approximately 1,020 Metres Distance from the Active Longwall 305**

	1 in 20 Probability of Exceedance (95% Confidence Level)	1 in 100 Probability of Exceedance (99% Confidence Level)	1 in 2000 Probability of Exceedance (99.95% Confidence Level)
Opening	5 mm	9 mm	20 mm
Closing	5 mm	9 mm	21 mm
Mid-Ordinate Deviation	8 mm	12 mm	18 mm

While located at a distance of 1.67 km from the northern end of Longwall 305, the predicted incremental relative opening and closing and mid ordinate deviation (based on far-field horizontal movements) have been used to assess differential horizontal movement of the ground at the Cawley Road Overbridge and their respective probability are provided in Table 6.

**Table 6**  
**Incremental Relative Opening, Closing and Mid-Ordinate Deviation at Approximately 1.67 Kilometres Distance from the Active Longwall 305**

	1 in 20 Probability of Exceedance (95% Confidence Level)	1 in 100 Probability of Exceedance (99% Confidence Level)	1 in 2000 Probability of Exceedance (99.95% Confidence Level)
Opening	4 mm	7 mm	14 mm
Closing	5 mm	9 mm	19 mm
Mid-Ordinate Deviation	7 mm	10 mm	16 mm

For Cawley Road Overbridge, the predicted incremental relative open and closing movement at a 1 in 2,000 probability of exceedance is 14 mm and 19 mm respectively and the predicted mid-ordinate deviation is 16 mm.

MSEC (2016) also identified potential movements at geological faults in cuttings (Appendix 1).

#### 4.2.1 Risk Assessment

In accordance with the *Guidelines for the Preparation of Extraction Plans* (DP&E and DRE, 2015) a risk assessment was conducted on 25 August 2016 for Longwalls 301-303, on 18 September 2018 for Longwalls 304-306 and on 20 August 2019 for Longwalls 305-307 by Arup Risk Consulting with representatives from the Technical Committee (TFNSW) (Appendices 5, 6 and 7).

The TFNSW assets considered in the risk assessment included:

- Bridge 2 – BN616 (southbound) and BN617 (northbound);
- Cawley Road Overbridge – BN615;
- carriageway;
- culverts;
- kerb;
- cuttings;
- embankments;
- roadside furniture;
- drains;
- Variable Message Sign (VMS); and
- other structures such as power lines (which are not TFNSW assets but failure may affect TFNSW assets).

Subsidence management procedures considered in the risk assessment included:

- High Accuracy Fibre Optic Monitoring System - Fibre Bragg Grating (FBG);
- Real time absolute monitoring system – Global Navigation Satellite System (GNSS);
- Conventional Survey/Visual Inspections;
- Management Measures; and
- Contingency Measures.

The Longwalls 305-307 risk assessment used the risk register from previous studies (Longwalls 304-306, 301-303, 23-27 and 20-22) as a basis of discussion. In summary, a total of 18 risk events were identified during the workshop, of which 11 were not considered to present a credible risk (i.e. the level of possible impacts was not measurable).

This BFMP-TFNSW for Longwalls 305-307 addresses the events and activities identified in the risk assessment workshop and also takes into account the progression of potential mining impacts predicted from Longwalls 301-304.

The report *Metropolitan Colliery Longwall Mining – LW305-307 – Risk Assessment as Applied to RMS Assets* (Arup, 2019) is included in Appendix 7, and its details are referred to as required in the consideration of RMS (now TFNSW) assets below.

Metropolitan Coal – 305 - 307 Built Features Management Plan – Transport for NSW		
Revision No. BFMP_TFNSW-R01-D	ME-TSE-MNP-0088	Page 19
Document ID: Built Features Management Plan - TfNSW		

### 4.3 BRIDGE 1 – OLD PRINCES HIGHWAY UNDERPASS (SOUTHERN)

Bridge 1 (TFNSW Reference BN618-northbound and BN619-southbound) is considered unlikely to experience any movement of concern for Longwalls 305-307 as it is located at distances greater than 2.5 km from extraction. Bridge 1 is therefore not considered any further in this BFMP-TFNSW.

### 4.4 BRIDGE 2 – OLD PRINCES HIGHWAY UNDERPASS

At the direction of the TFNSW Technical Committee, a detailed assessment of the potential effects on Bridge 2 – Old Princes Highway Underpass of the 1 in 100 and 1 in 2000 predicted relative ground movements (Table 5) resulting from extraction of Longwalls 301-303 was carried out by Cardno.

The findings of the assessment were provided in Cardno's report titled *Investigation of Potential Effects on Underpass 2 over Princes Highway of Ground Movement Due to Mining* issued in May 2015 (Cardno, 2015a) and a supplement to that report issued in July 2015 (Cardno, 2015b). Other past reports relating to Bridge 2 are provided in the reference list (Cardno, 2008; 2009a; 2009b; 2009c; and 2013).

As for Bridge 1, it was determined that ground movement effects only needed to be considered in the Serviceability Limit State, not the Ultimate Limit State, provided that the structures have sufficient plastic capacity and this approach is in accordance with AS 5100. In the Serviceability Limit State, the control of the widths of cracks in concrete members is the primary focus.

The analysis showed that, with the effects of the 1 in 100 probability relative horizontal ground movements included, the flexural crack control provisions generally still complied with the requirements of Australian Standard (AS) 5100:2007 – *Bridge Design*. Under adverse patterns of differential ground movement, crack widths at only two sections in Abutment B could exceed the allowable limits with a maximum estimated crack width of 0.65 mm. As required by AS 5100, the abutment and pier structures would have sufficient capacity for plastic deformations under this loading. Flexural cracks of width less than 0.5 to 1mm only affect the appearance of the bridge and will not otherwise affect the strength or durability of the structure. They can readily be repaired.

However, the analysis showed that, with the effects of the 1 in 2000 probability relative horizontal ground movements included, the flexural crack widths at particular sections of the abutment and pier frames could significantly exceed allowable limits under adverse patterns of differential ground movement with the potential for stresses in reinforcement to exceed the tensile capacity of reinforcing bars. This effectively would mean failure of the concrete sections.

The assessment determined that the bridge superstructures and bearings are generally not adversely affected by differential ground movements because the articulation allows for such movements. However, it was determined that there is potential for local crushing of the girder concrete at the contact point of the dowel restraints at the piers. The short term ramifications of such limited local crushing are considered to be acceptable structurally as the girders would continue to be adequately supported and an alternative mechanism to provide horizontal restraint of the superstructure is available and has sufficient capacity.

As the crushing could develop after only a few millimetres of differential ground movement (if the pattern of ground movement is adverse) the magnitude of horizontal movement of girders relative to their supporting headstocks should be limited to 10 to 15 mm. It is noted that the bearing and dowel restraint details at Bridge 2 are different to those at Bridge 1 resulting in Bridge 2 being significantly more sensitive to forces on dowel restraints from ground movement effects.

Metropolitan Coal – 305 - 307 Built Features Management Plan – Transport for NSW		
Revision No. BFMP_TFNSW-R01-D	ME-TSE-MNP-0088	Page 20
Document ID: Built Features Management Plan - TfNSW		

Cardno was also asked by the TFNSW Technical Committee to investigate and report on the methods and implementation of monitoring of Bridge 2 to detect the effects of relative ground movements. The final version of the Monitoring Report for Bridge 2 was issued in July 2015. The report included details of the implementation of an additional system of higher accuracy distortion measurements based on the use of FBG “extensometers” (measuring change in distance between two points) and tiltmeters.

#### 4.5 CAWLEY ROAD OVERBRIDGE

At the direction of the TFNSW Technical Committee, a detailed assessment of the potential effects on Cawley Road Overbridge of the 1 in 100 and 1 in 2000 predicted relative ground movements (Table 6) resulting from extraction of Longwalls 301-303 was carried out by Cardno.

The findings of the assessment were provided in Cardno’s report titled *Investigation of Potential Effects on Cawley Road Overbridge of Ground Movement Due to Mining* issued in October 2016 (Cardno, 2016).

It should be noted that Cawley Road Overbridge is currently not in regular use and is only open to traffic in emergency situations.

As for Bridges 1 and 2, it was determined that ground movement effects only needed to be considered in the Serviceability Limit State, not the Ultimate Limit State, provided that the structures have sufficient plastic capacity and this approach is in accordance with AS 5100. In the Serviceability Limit State, the control of the widths of cracks in concrete members is the primary focus.

The assessment found that differential ground movements in the longitudinal direction of the bridge, either opening or closing, between the abutments do not result in any unacceptable effects for either the 99.95% confidence level (1 in 2000 probability) or the 99.0% confidence level (1 in 100 probability) ground movements when combined with normal in service permanent and transient loads.

The effects of differential ground movements in the transverse direction of the bridge depend on the transverse capacity of the guided sliding bearings at the abutments but these are unknown.

If the lateral capacity of the bearings is high, significant horizontal bending of the deck and transverse force on the pier could occur. However, in the worst case scenario for these effects in which the lateral capacity of the bearings is not exceeded, the effects on the deck and pier are within allowable limits.

Alternatively, if the lateral capacity of the guided sliding bearings is low, they could “fail” under differential transverse ground movements. However, “failure” of these bearings simply means that slip will occur at the interfaces near the top of the bearing. The magnitude of the slip could result in contact between the upper steel plate of the bearing and the concrete nib of the end diaphragm beam, resulting in minor spalling and possible minor distortion of the steel traffic railing and safety screen.

#### 4.6 CARRIAGEWAY

Whilst measurable conventional subsidence movements are anticipated to be very small for the M1 Princes Motorway, potential movement of fault lines may result in impacts to the pavement. The M1 Princes Motorway crosses the Metropolitan Fault approximately 500 m to the north-east of Longwall 301. Several other faults to the south-east of Longwalls 301-304 also intersect the M1 Princes Motorway at distances of approximately 340 m.

The approximate locations of the faults are illustrated in Figure 5. There are no identified geological features directly above the longwalls.

Metropolitan Coal –305 - 307 Built Features Management Plan – Transport for NSW		
Revision No. BFMP_TFNSW-R01-D	ME-TSE-MNP-0088	Page 21
Document ID: Built Features Management Plan - TfNSW		

It is possible that irregular movements could develop at the location of the faults or that anomalous movements could occur at unknown geological features as a result of the extraction of the longwalls. These have occurred in the past in the Southern Coalfield, though is less likely at these distances.

Previous impacts have occurred as a result of mining operations below the M1 Princes Motorway during the late 1970s. The majority of impacts to the pavement during mining at the Coal Cliff and Metropolitan Collieries consisted of pavement cracking. However, steps in the order of 40 mm to 80 mm in height also occurred at two locations during mining.

The first step occurred during total extraction mining at Coal Cliff Colliery and ground monitoring indicated that irregular movements had developed at this location, comprising a local upsidence bump at the impact location coupled with a localised high compressive ground strain of approximately 1.6 mm/m after the step had occurred.

The second step occurred during mining at Metropolitan Colliery where the M1 Princes Motorway crossed above a large valley at Kelly's Creek. It is considered likely that valley upsidence and closure movements developed in the base of the valley, though no ground monitoring had been installed at the valley base to confirm this. Ground monitoring along the top of the embankment (maximum height of approximately 25 m), however, measured compressive strains over a long length of the embankment.

The steps in the M1 Princes Motorway pavement occurred only at locations where mining extended below the carriageway. Whilst it is expected that there is a low risk of impacts to the M1 Princes Motorway pavement due to the extraction of Longwalls 301-304, it was agreed by the Technical Committee that monitoring along the M1 Princes Motorway would be conducted for the extraction of Longwalls 301-304 and will continue for Longwalls 305-307.

The M1 Princes Motorway pavements are located some 1,000 m or more from Longwall 305. The pavement is not expected to experience measurable conventional strain due to the extraction of Longwalls 305-307 (MSEC, 2019) (Appendix 3).

#### 4.7 CULVERTS AND DRAINAGE STRUCTURES

There are a number of culverts east of Longwalls 301-307 (Figure 5). In addition to the culverts, there are also a number of other drainage structures, such as kerbs, gutters, pits and drainage pipes. There is the potential for far-field movements and non-conventional movements to impact the culverts and other drainage structures, however these movements are expected to be of a small order (refer Appendices 1, 2 and 3). Measurable valley closure movements resulting from Longwalls 305 to 307 are not expected to occur (refer Appendices 1, 2 and 3). Hence adverse impacts on drainage structures associated with these movements are considered unlikely.

The risk assessments (Appendices 4, 5 and 6) identified that cracking of culverts that contain asbestos was a potential risk. Based on previous assessments, it was deemed very unlikely that the asbestos fibres (which are bound into the cement) would be released into the environment and be hazardous to the health and safety of the public, if cracking of the asbestos cement pipes was to occur. The proposed mitigation in the case of culverts cracking is to inspect the area of damage and to sleeve the pipe if necessary to contain the asbestos.

#### 4.8 M1 PRINCES MOTORWAY CUTTINGS

There are several rock cuttings along the M1 Princes Motorway east of Longwalls 305-307. The locations of the cuttings are shown in Figure 5.

Metropolitan Coal – 305 - 307 Built Features Management Plan – Transport for NSW		
Revision No. BFMP_TFNSW-R01-D	ME-TSE-MNP-0088	Page 22
Document ID: Built Features Management Plan - TfNSW		

There is the potential for far-field movements and non-conventional movements to impact the rock cuttings, however potential impacts and the consequences associated with these movements are considered to be very low.

The cuttings were stabilised and rerated prior to the extraction of Longwall 301 as part of the TFNSW slope maintenance program to improve their Assessed Risk Level (ARL) in accordance with the TFNSW Guide to Slope Risk Analysis (TFNSW, 2014). The stabilisation measures changed the ARL from the pre-stabilisation ARL2 to a post-stabilisation ARL3 or ARL4. During the extraction of Longwall 303 in 2018 the cuttings were reassessed as follows:

- Cutting 10425: ARL2 to ARL3;
- Cutting 13560: ARL4 to ARL3; and
- Cutting 13562: ARL4 to ARL3.

The 2018 cuttings rerating was due to natural effects and were not related to mining.

The low levels of movement expected as a result of extraction of Longwalls 305 to 307 are not expected to have any impacts on the ARL of the stabilised slopes.

#### 4.9 VARIABLE MESSAGE SIGN STRUCTURES AND ROADSIDE FURNITURE

Negligible impact is predicted for the Variable Message Sign structures and roadside furniture.

### 5 PERFORMANCE MEASURES AND INDICATORS

#### 5.1 PERFORMANCE MEASURES

The Project Approval requires Metropolitan Coal not to exceed the subsidence impact performance measures outlined in Table 1 of Condition 1, Schedule 3. The subsidence impact performance measure specified in Table 1 of Condition 1, Schedule 3 in relation to built features is:

*Safe, serviceable and repairable, unless the owner and the MSB agree otherwise in writing.*

#### 5.2 PERFORMANCE INDICATORS

A summary of the performance indicators proposed to ensure that the above performance measure is achieved include:

- measured absolute horizontal movements;
- distortion of bridge elements;
- cracking of bridge elements;
- pavement cracking and deformation;
- visual consequences of slope movement; and
- defects in culverts.

These are described in more detail below.

Metropolitan Coal –305 - 307 Built Features Management Plan – Transport for NSW		
Revision No. BFMP_TFNSW-R01-D	ME-TSE-MNP-0088	Page 23
Document ID: Built Features Management Plan - TfNSW		

Section 7 of this BFMP-TFNSW describes the monitoring that will be conducted to assess the Project against the above performance indicators. Section 8 describes the management measures that will be implemented in the event that one or more of the performance indicators are exceeded. Section 9 of this BFMP-TFNSW provides a Contingency Plan in the event the performance measure is exceeded or is considered likely to be exceeded.

### 5.2.1 Bridge Distortion and Cracking

The following limits are used for monitoring the performance of the bridges:

- absolute 3D horizontal movement of survey lines (M1 Northbound Line) of 50 mm or more at key points on the ground near the bridge;
- relative movement of 5 mm or more between any two points monitored by the conventional survey system;
- relative movement of 2 mm<sup>4</sup> or more between any two points monitored by the FBG sensor system; and
- crack in concrete elements exceeding 0.2 mm width.

The above limits were adopted to provide a reasonable indicator of ground movements, including differential movements, and distortion of the bridge as a result of extraction of the longwalls. Should any of these limits be exceeded, structural analysis along with more detailed monitoring would be used to assess the ongoing performance of the bridges. Following the completion of Longwall 303, a review of the absolute 3D horizontal movement of survey lines was undertaken by the TFNSW technical committee. In the absence of other reliable absolute horizontal movements, the real time GNSS monitoring site GNSS03 was being used for assessment of the absolute horizontal movements. Given the location of site GNSS03 is closer to the extracted longwalls than Bridge 2, an assessment of the GNSS03 records was carried out, resulting in revising the absolute horizontal movement to 50 mm<sup>5</sup> (Appendix 10).

The monitoring systems, locations and frequency are outlined in Section 7.

### 5.2.2 M1 Princes Motorway Pavement Deformation

The performance indicators for the pavement include:

- a measured compressive ground strain of greater than 0.5 mm/m;
- pavement cracking;
- deterioration in ride quality; and
- defects in minor structures such as kerbs and gutters, pits, etc.

<sup>4</sup> At TCM2-21MC, 3 August 2021, the Technical Committee reviewed the monthly monitoring records on subsidence impacts for Longwalls 305 and 306 over a 14 month period and agreed that the FBG system on Bridge 2 was no longer required and decommissioning was appropriate. The 2 mm indicator was applicable for Longwalls 305 and 306 up to 3 August 2021.

<sup>5</sup> AECOM memorandum, 20 Aug 2019, provided to TFNSW Technical Committee, *Metropolitan Coal LW304 Trigger review – Bridge 2 trigger review*, 60546746.

Metropolitan Coal –305 - 307 Built Features Management Plan – Transport for NSW		
Revision No. BFMP_TFNSW-R01-D	ME-TSE-MNP-0088	Page 24
Document ID: Built Features Management Plan - TfNSW		

### 5.2.3 Cuttings and Faults

The performance indicators for the cuttings include:

- a measured ground strain of greater than 0.5 mm/m;
- rock falls;
- cracking or visual deterioration at the rock face; and
- visual displacement at joints.

### 5.2.4 Culverts

The performance indicators for the culverts include:

- visual displacement at joints;
- cracks in culverts; and
- ponding.

## 6 BASELINE DATA

### 6.1 GENERAL

The reports on the baseline data will be made available in accordance with the distribution register outlined in Section 2.1.

### 6.2 BRIDGE 2 – OLD PRINCES HIGHWAY UNDERPASS

An inspection of the Bridge 2 structure to record its existing (baseline) condition was conducted prior to the commencement of Longwall 20. The baseline condition of this bridge was confirmed by further inspections in 2013, 2015 and 2016 prior to Longwall 301 extraction.

The conventional survey monitoring points were installed on this bridge prior to the commencement of Longwall 20. Then initial (baseline) relative 3D survey was carried out in February 2011. A further survey was conducted prior to the commencement of Longwall 301 in 2016. End of panel surveys were completed following extraction of Longwalls 301, 302, 303 and 304.

### 6.3 CAWLEY ROAD OVERBRIDGE

An inspection of the Cawley Road Overbridge was conducted prior to extraction of Longwall 301.

Conventional survey monitoring points are installed on this bridge and the initial (baseline) relative 3D survey was carried out prior to extraction of Longwall 301. End of panel surveys were completed following extraction of Longwalls 301, 302 and 303.

Metropolitan Coal –305 - 307 Built Features Management Plan – Transport for NSW		
Revision No. BFMP_TFNSW-R01-D	ME-TSE-MNP-0088	Page 25
Document ID: Built Features Management Plan - TfNSW		

## 6.4 M1 PRINCES MOTORWAY PAVEMENT

Ground monitoring pegs are established along the M1 Princes Motorway in accordance with the ground monitoring plan, which is described below. The ground monitoring pegs were surveyed by 3D survey methods prior to the commencement of Longwall 301.

The existing pavement condition will be assessed from data obtained using the TFNSW RoadCrack, Gipsicam and Laser Profilometer pavement assessment systems which are conducted in accordance with the TFNSW inspection program.

In addition to the pavement assessment system, a visual inspection of the kerbs and gutters, pits signs and other road infrastructure was carried out by the TFNSW to provide an assessment of the baseline of condition of these features prior to the extraction of Longwall 301.

## 6.5 CUTTINGS

There are several rock cuttings along the M1 Princes Motorway (Figure 5). A summary of the TFNSW rock cuttings is provided in Table 7.

Stabilisation of the cuttings has been carried out as part of the TFNSW slope maintenance program prior to extraction of Longwall 301. Post stabilisation slope risk assessments in accordance with the TFNSW Guide to Slope Risk Analysis (TFNSW, 2014) form the baseline survey for these slopes.

**Table 7**  
**TFNSW Rock Cutting Details**

TFNSW Slope Number	Length (m)	Maximum Slope Height (m)	Average Slope Angle (degrees)
10425	188	9	66
10426	503	15	55
10427	452	14	55
10428	192	9	65
13560	231	8	70
13561	599	13	62
13562	531	18	70
13563	202	17	65

## 6.6 CULVERTS

TFNSW conducted a site inspection of the culverts prior to commencement of Longwall 301 to establish the condition of the culverts. The inspection included:

- recording of existing cracks;
- recording of other defects and general condition;
- two dimensional image records of the affected structures; and
- condition of the access roads with specific attention to surface cracks.

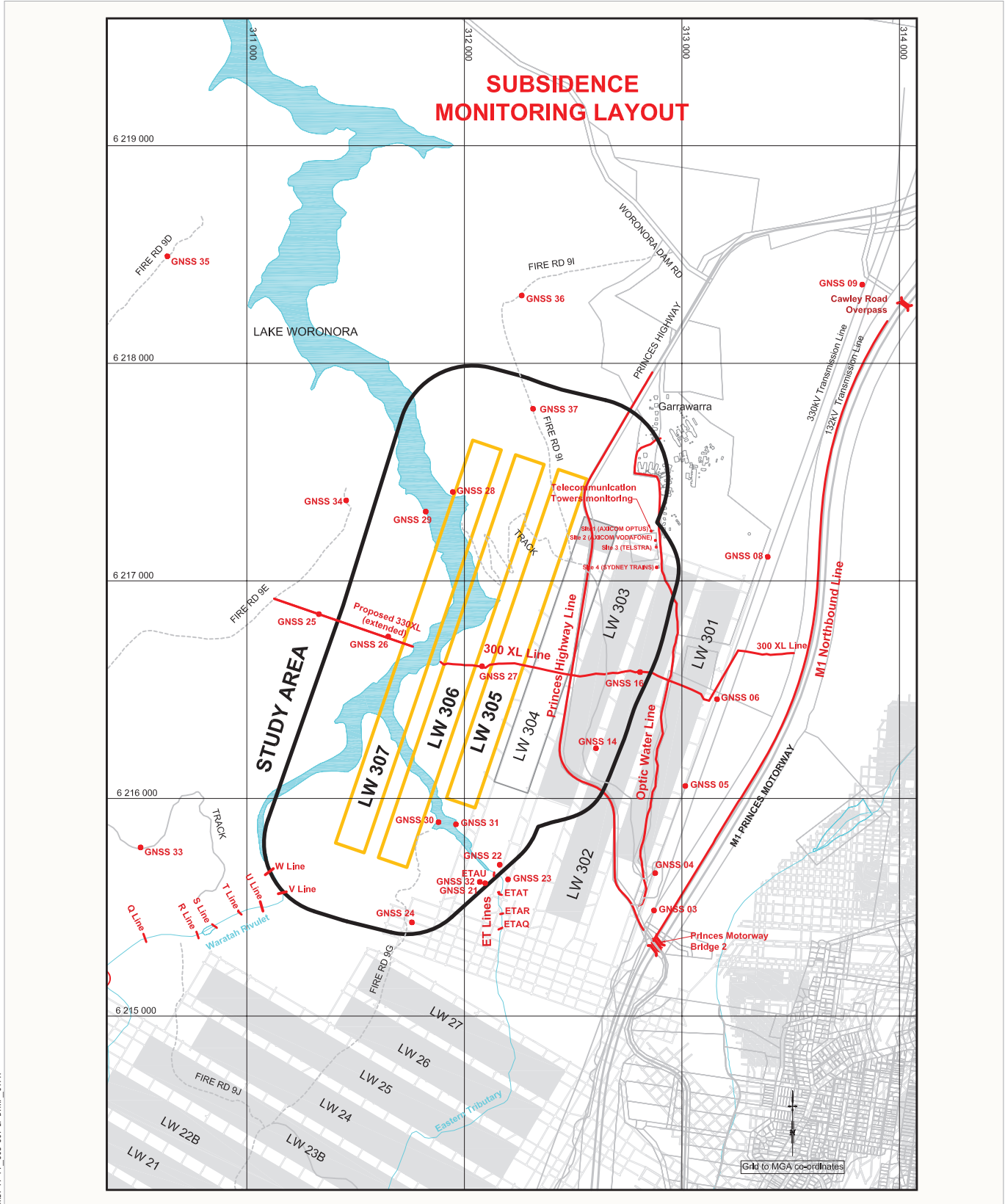

Source: MSEC (2019)

Figure 6

## 6.7 GROUND MONITORING

The details of ground monitoring are provided in Metropolitan Coal Longwalls 305-307 Subsidence Monitoring Program (SMP). The monitoring locations include:

- 3D monitoring along the M1 Princes Motorway (Northbound Line<sup>6</sup>);
- 3D monitoring along the transmission tower easement (Towers); and
- 3D monitoring of 300 XL Line.
- GNSS monitoring at key locations on the motorway corridor (Northbound)

The locations of established monitoring are shown in Figure 6.

## 7 MONITORING

### 7.1 GENERAL

A number of monitoring and inspection programs will be undertaken during mining, which are described in this section.

The results of monitoring and inspections will be reported to the Technical Committee within 48 hours of gathering the monitoring or inspection data.

All performance indicators and monitoring frequency would be reviewed by the Technical Committee in the event that performance indicators are exceeded.

Where relevant, inspections of subsidence impacts will include photographic record of the impacts for comparison with baseline photographic records.

The TFNSW or their delegates will conduct the various visual inspections. Metropolitan Coal will be notified of the timing of inspections and accompany the TFNSW or delegates if considered necessary. All personnel will complete necessary inductions or orientation relevant to the tasks required.

### 7.2 BRIDGE MONITORING METHODS

As for Bridge 1 during the mining of Longwalls 20 to 27, Bridge 2 and Cawley Road Overbridge will be monitored by visual inspections and by measurements to determine the distortion of, and movements within, the structures.

<sup>6</sup> The M1 Motorway ground monitoring points were discontinued after final survey on 29 October 2021 (during Longwall 306) prior to scheduled pavement resurfacing works. It was considered reasonable by the Technical Committee to discontinue with the terrestrial monitoring method due to a prolonged period of no discernible subsidence, mining moving further away and the possible range of future subsidence movements diminishing further.

Baseline visual inspections are carried out to identify any defects in the bridge that are present before ground movements due to mining can occur. Further visual inspections are carried out at key stages during longwall mining and when measurements taken indicate that ground movements may have caused adverse effects on the bridge. A baseline visual inspection of Bridges 1 and 2 was carried out before commencement of Longwall 20 and before commencement of Longwall 23. A further inspection of Bridge 2 and the initial baseline inspection of Cawley Road Overbridge was carried out prior to the extraction of Longwall 301.

As for Bridge 1, measurements of Bridge 2 and Cawley Road Overbridge to determine distortion and movements will include conventional survey of targets fixed to key points on the structures to determine relative movement between those points. These relative 3D survey measurements will be undertaken using an automated total station to an accuracy of  $\pm 2.5$  mm. Relative 3D movements between each point and every other point on the same structure will be calculated from the survey measurements. Shade air temperatures will be recorded during any bridge survey to give an indication of change in temperature of the bridge structure, and hence thermal expansion.

Absolute 3D survey measurements of at least one key point on or fixed to the ground near each bridge will be taken to determine the overall movement of the bridge site. The absolute 3D survey will be undertaken using total station survey methods to an accuracy of  $\pm 12$  mm, or using a real time survey system that tracks absolute movements in real time (see below under heading **Real-Time Monitoring**).

The absolute movements of the bridge sites from these surveys will be used to determine the commencement and frequency of relative 3D surveys on the basis that differential ground movement can only occur if there is significant absolute movement of the site.

Because the accuracy of the conventional 3D survey of targets is significantly less than desirable for the detection of structural distortions, an additional measurement system has been set up on Bridge 2. This system uses high accuracy FBG sensors to measure the change in distance between key points on the bridge. The FBG sensor “cables” are suspended between their attachment points on the bridge, within protective conduits. The accuracy of length change measurement is better than 0.1mm.

While far more accurate than conventional survey, it is only feasible to monitor relative movement of some of the key points on the bridge using the FBG sensor system.

When of sufficient (triggered) magnitude, relative 3D movements between each point and every other point, calculated from the survey and FBG sensor measurements will be fed into the structural computer model of the bridge to determine whether the ground movement effects, in combination with other “in service” design loads and effects on the bridge (both existing permanent and potential transient) would have unacceptable consequences (excessive crack widths, crushing of concrete, etc).

The FBG system was decommissioned during the extraction of Longwall 306 after consideration of some 14 months of monitoring results by the Technical Committee (TC2-21, 3 August 2021) that deemed it was no longer required because of comparable results from the GNSS unit operating in tandem with the FBG system. Absolute monitoring continues at Bridge 2 with the GNSS system.

### **Real-Time Monitoring**

Metropolitan Coal trialled a new survey monitoring system during the extraction of Longwall 301 and Longwall 302 to provide single point real time absolute movements with higher accuracy and consistencies than traditional survey methods. A review by the Technical Committee confirmed the system effectiveness and endorsed the use of real time monitoring in the BFMP-TFNSW as an additional management tool particularly effective when considering TARP triggers.

Metropolitan Coal – 305 - 307 Built Features Management Plan – Transport for NSW		
Revision No. BFMP_TFNSW-R01-D	ME-TSE-MNP-0088	Page 29
Document ID: Built Features Management Plan - TfNSW		

Shown in Figure 6, GNSS stations are installed nearby Bridge 2 and Cawley Road Bridge, additionally a line of GNSS stations provide real time data parallel to Longwall 301 and between the motorway and Longwall 301

### 7.3 MONITORING OF BRIDGE 2 – OLD PRINCES HIGHWAY UNDERPASS

#### 7.3.1 Relative 3D Survey

The system for relative 3D survey of this bridge using conventional survey equipment was installed prior to the commencement of Longwall 20. Subsequently, improvements to the survey monitoring system were identified and implemented to provide better quality survey results, particularly for the ground targets.

The locations of the bridge monitoring points (targets) are illustrated in Figures 7 to 15 and are summarised in Table 8.

It is noted that it has not been possible to achieve the ideal arrangement of monitoring points in which there would be points attached at each pier and abutment foundation. These are buried a significant distance below the ground surface. The diagrams have been drawn for Bridge 1. At Bridge 2, the pier pad footings are much closer to the ground surface so targets near the bottom of columns (suffix C) are much closer to the pad footings than indicated.

**Table 8**  
**Bridge 2 - 3D Survey Monitoring Locations**

Carriageway	Location	Abutment A	Pier 1	Pier 2	Abutment B
North Bound Carriageway	South Column or Blade Wall	1H, 1D, 1D2	17H, 17D1, 17D2, 17C, 17G	25H, 25D1, 25D2, 25C, 25G	9H, 9D1, 9D2, 12.5G
	Internal Column or Blade Wall	-	18H, 18C, 18G	26H, 26C, 26G	-
	Internal Column or Blade Wall	-	19H, 19C, 19G	27H, 27C, 27G	-
	North Column or Blade Wall	4H, 4D1, 4D2, 4.5G	20H, 20D1, 20D2, 20C, 20G	28H, 28D1, 28D2 28C, 28G	12H, 12D1, 12D2, 12.5G
South Bound Carriageway	South Column or Blade Wall	5H, 5D, 4.5G	21H, 21D1, 21D2, 12G	29H, 29D1, 29D2, 29C, 29G	13H, 13D
	Internal Column or Blade Wall	-	22H, 22C, 22G	30H, 30C, 30G	-
	Internal Column or Blade Wall	-	23H, 23C, 23G	31H, 31C, 31G	-
	North Column or Blade Wall	8H, 8D	24H, 24D1, 24D2, 24C, 24G	32H, 32D1, 32D2 32C, 32G	16H, 16D

Notes:

H = face of headstock (facing old Princes Highway).

D = Deck girder – outside face on the bottom flange.

C = Column – close to ground level.

G = Ground adjacent to pier column or blade wall.

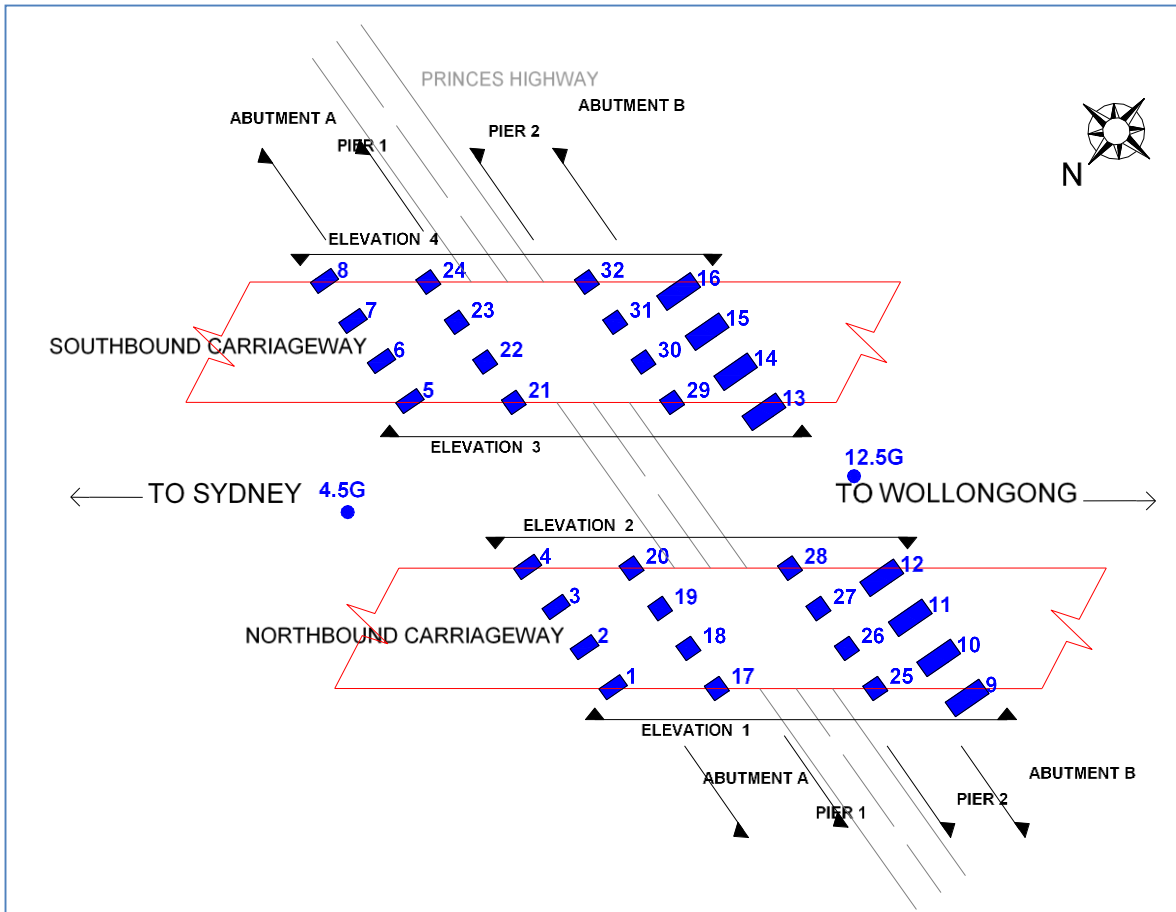

Figure 7: Bridge 2 - Column and Blade Wall Plan View

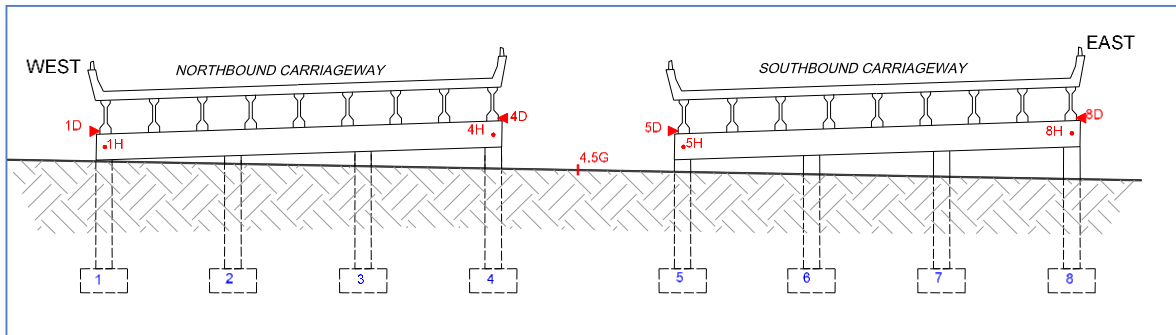

Figure 8: Bridge 2 - Abutment A – Relative 3D Monitoring Locations

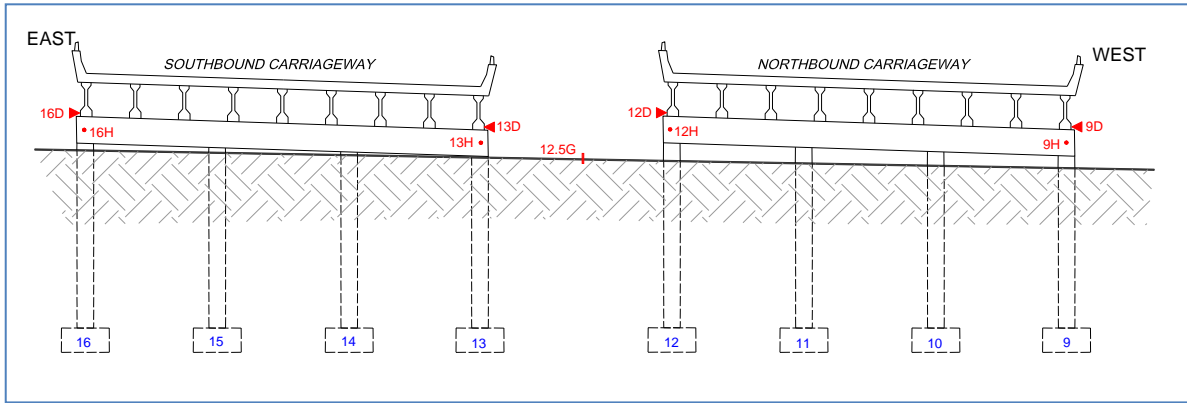

Figure 9: Bridge 2 - Abutment B – Relative 3D Monitoring Locations

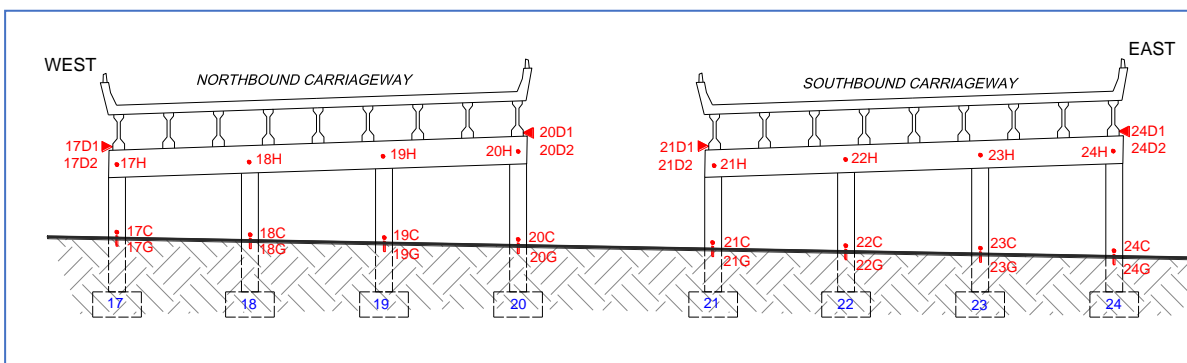

Figure 10: Bridge 2 - Pier 1 – Relative 3D Monitoring Locations

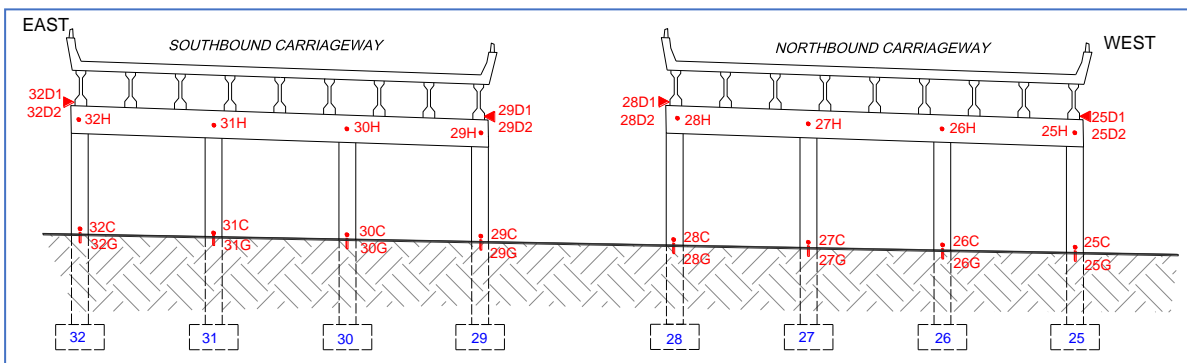

Figure 11: Bridge 2 - Pier 2 – Relative 3D Monitoring Locations

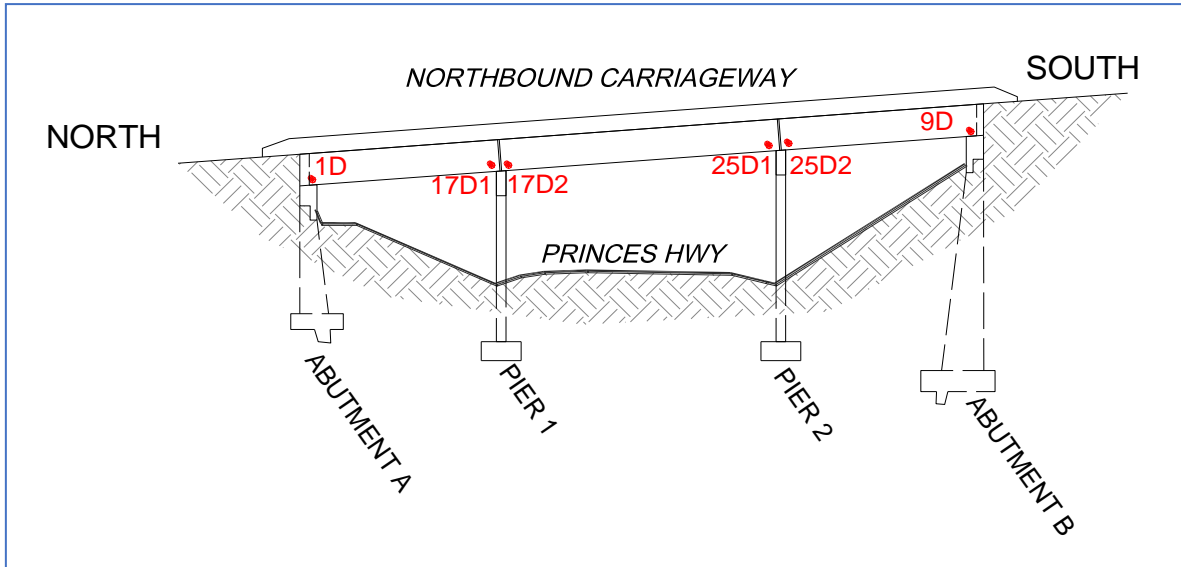

Figure 12: Bridge 2 - Deck Girders – Elevation 1 – Relative 3D Monitoring Locations

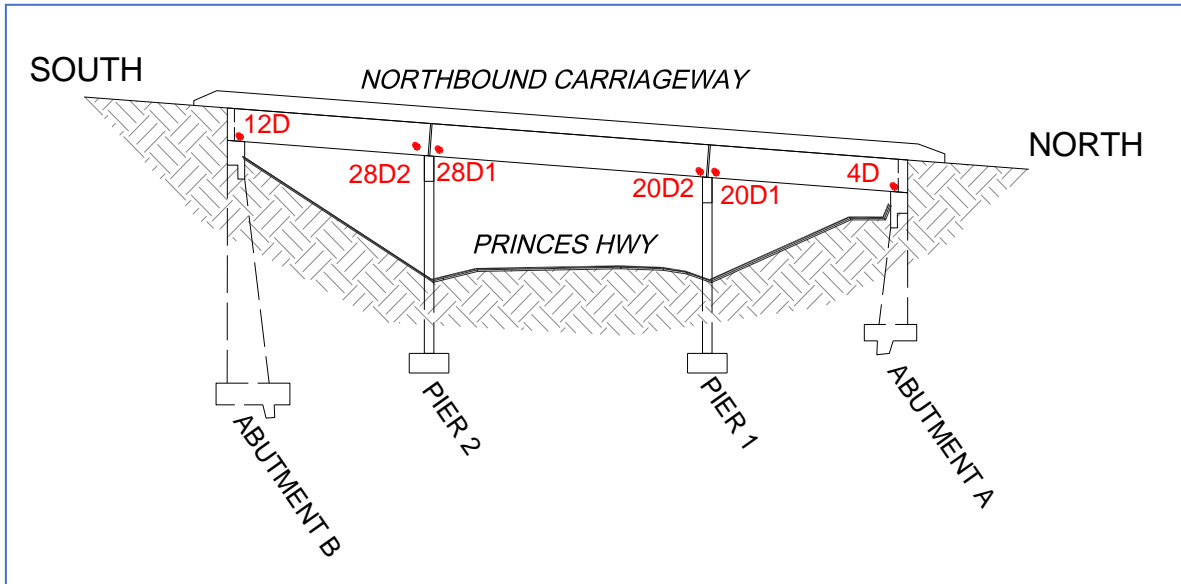

Figure 13: Bridge 2 - Deck Girders – Elevation 2 – Relative 3D Monitoring Locations

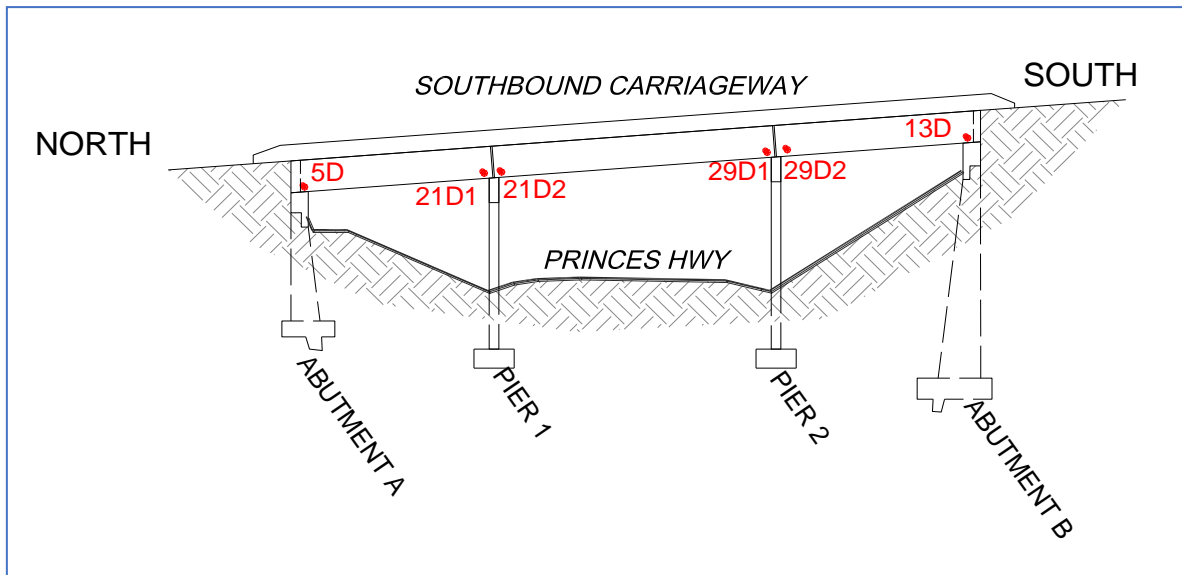

Figure 14: Bridge 2 - Deck Girders – Elevation 3 – Relative 3D Monitoring Locations

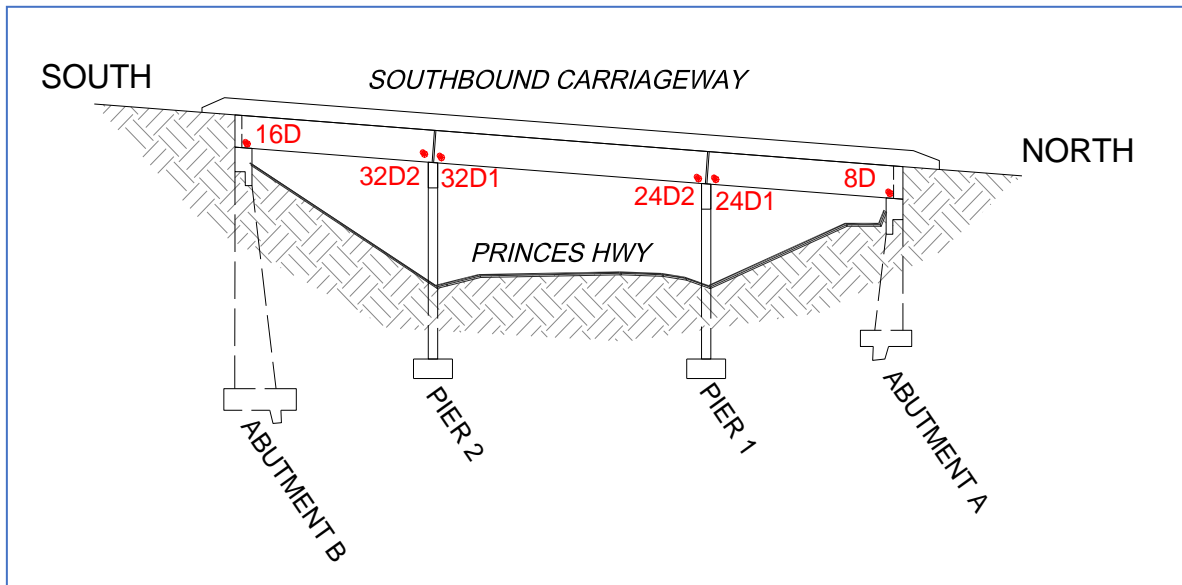

Figure 15: Bridge 2 - Deck Girders – Elevation 4 – Relative 3D Monitoring Locations

### 7.3.2 FBG Sensor Measurements

The Technical Committee decided that a system for high accuracy measurement of structure distortions using FBG sensors should be installed to monitor the relative horizontal movement between points at the end of each pier and abutment headstock and the transverse tilts of one outer column at each pier. Monitoring of in-plane and out-of-plane distortions of the pier frames using FBG "extensometer" sensors was considered impractical to implement and monitoring of relative movements of other key points on the structure using these sensors was not physically possible.

Although only a limited number of key points on the bridge could be monitored using this system, it was considered to be beneficial because the high accuracy would allow early detection of small relative ground movements which could then be monitored more closely using all available methods.

The FBG sensor layout for monitoring the relative horizontal movement between points at the end of each pier and abutment headstock is shown on Figure 16. The FBG tiltmeter layout is shown on Figure 17.

From the change in length of each of the sensors shown in Figure 16, the horizontal movement of each attachment point, in the X and Y coordinate directions can be calculated mathematically. Those movements can then be fed into the computer model of the structure for assessment of the effects of the movement. Note that the capture of FBG sensor readings is largely automated.

The frequency of readings has been adjusted to suit monitoring requirements with consideration to diurnal and seasonal trends, and has been conditioned to filter out changes due to traffic effects.

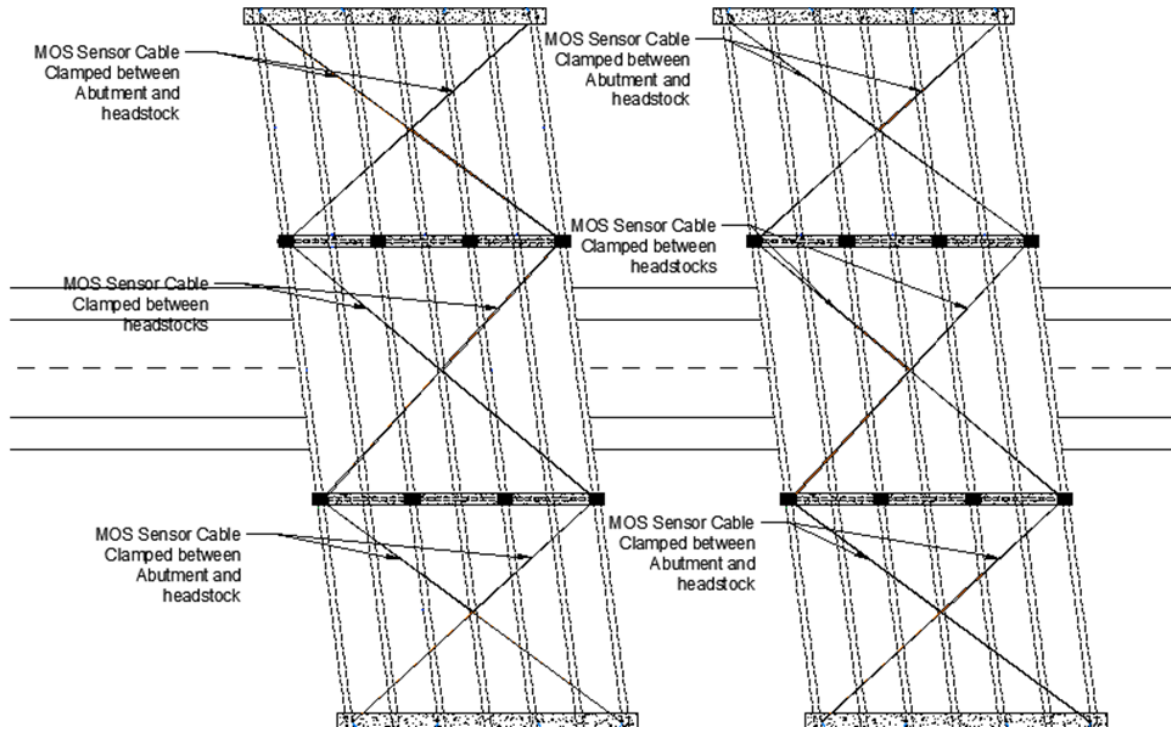

**Figure 16: Bridge 2 - FBG Sensor Layout – Abutment Pier Headstocks**

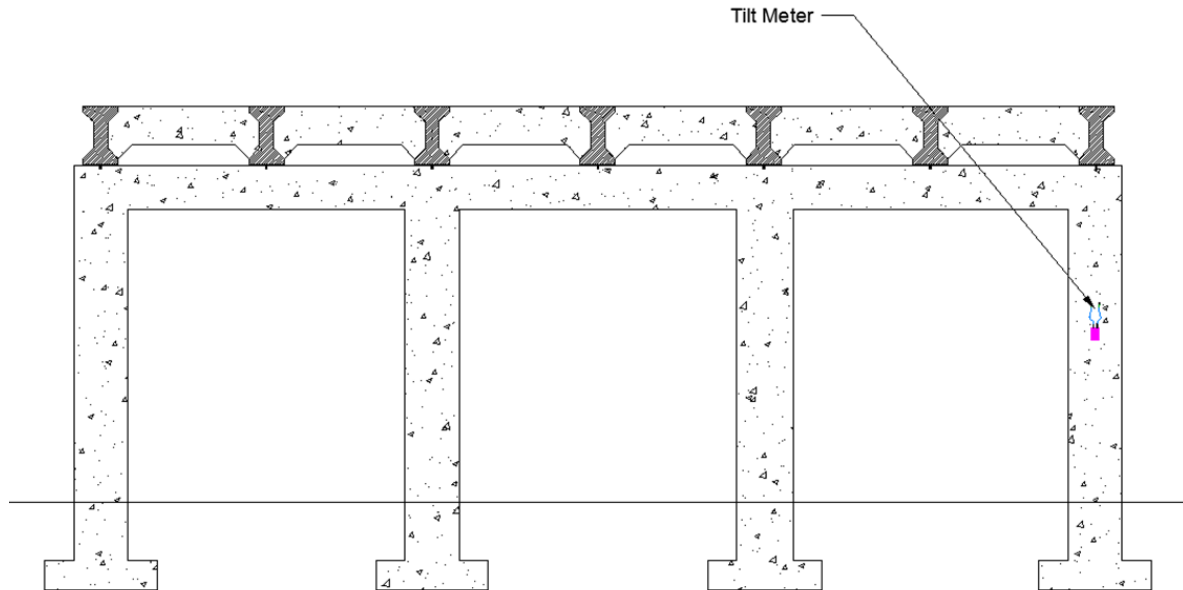

**Figure 17: Bridge 2 - FBG Tiltmeter Layout – Pier Columns**

### 7.3.3 Survey Frequency

Re-survey of Bridge 2 targets will occur:

- prior to extraction of Longwall 305; and if
- absolute horizontal movement of survey station - GNSS Site#3 near Bridge 2, indicate more than 50 mm of horizontal movement;

Monitoring frequency of Bridge 2 will be reviewed if:

- absolute horizontal movement of survey station - GNSS Site#3 near Bridge 2, indicate more than 50 mm of horizontal movement;
- FBG sensor monitoring detects significant distortion of the structure;
- visual inspection indicates cracking; or
- if otherwise determined in consultation with the Technical Committee.

It is envisaged by the Technical Committee that the frequency of conventional survey monitoring, after 50 mm of absolute movement is measured at GNSS Site#3 or significant structure distortion is detected by the FBG sensor system, will be increased to weekly. The frequency may be reduced if the FBG sensor system readings indicate that relative ground movements are developing slowly.

### 7.3.4 FBG Monitoring Frequency

The FBG sampling frequency during extraction of Longwall 305-306 will be three readings per week, although weekly readings are considered sufficient, even if significant relative ground movements are occurring.

The FBG monitoring frequency will be increased if determined in consultation with the Technical Committee.

Metropolitan Coal – 305 - 307 Built Features Management Plan – Transport for NSW		
Revision No. BFMP_TFNSW-R01-D	ME-TSE-MNP-0088	Page 36
Document ID: Built Features Management Plan - TfNSW		

### 7.3.5 Visual Inspections

The most recent visual inspection of Bridge 2 was carried out in March 2020 for end of panel Longwall 304 and prior to the commencement of this BFMP 305-307. The conclusion of this inspection was that there was no evidence of any recent impact on the structures that could be attributed to the mining of LW304.

Visual inspection of Bridge 2 will be conducted at the completion of Longwall 307 or otherwise if determined in consultation with the Technical Committee.

## 7.4 MONITORING OF CAWLEY ROAD OVERBRIDGE

### 7.4.1 Relative 3D Survey

The system for relative 3D survey of this bridge using conventional survey equipment was installed prior to the commencement of Longwall 301.

The locations of the bridge monitoring points (targets) are illustrated in Figure 18.

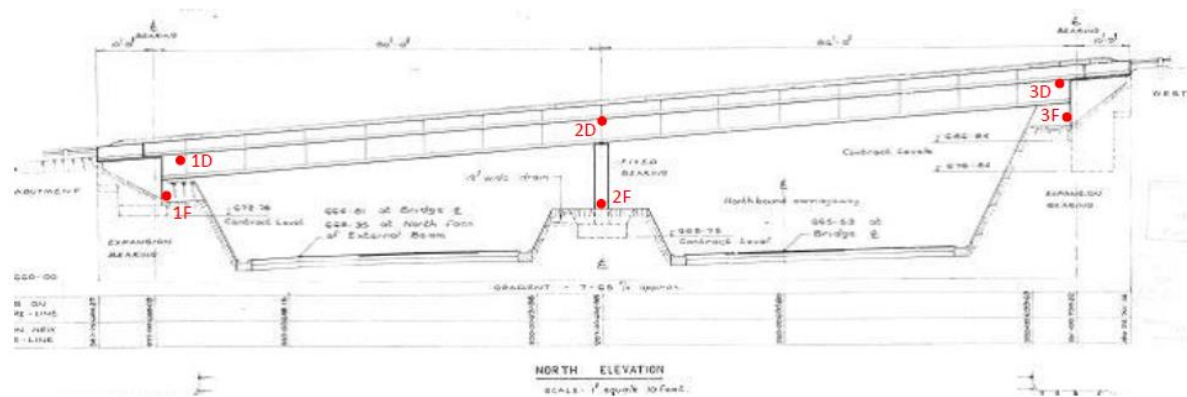

**Figure 18: Cawley Road Overbridge – Survey Monitoring Points**

### 7.4.2 Survey Frequency

Survey of Cawley Road Overbridge targets will occur:

- prior to extraction of Longwall 305 (baseline survey); and
- within 3 months of the completion of Longwall 307.

Monitoring frequency of Cawley Road Overbridge will be reviewed if:

- absolute horizontal movement of survey station GNSS Site #9 indicate more than 30 mm of horizontal movement;
- visual inspection indicates cracking; or
- if otherwise determined in consultation with the Technical Committee.

It is envisaged by the Technical Committee that the frequency of conventional survey monitoring, after 30 mm of absolute movement is measured, will be increased to weekly.

Metropolitan Coal – 305 - 307 Built Features Management Plan – Transport for NSW		
Revision No. BFMP_TFNSW-R01-D	ME-TSE-MNP-0088	Page 37
Document ID: Built Features Management Plan - TfNSW		

### 7.4.3 Visual Inspections

A visual inspection was conducted prior to the extraction of Longwall 301. The most recent visual inspection of Cawley Road Overbridge was carried out in March 2020 for end of panel Longwall 304.

Visual inspection of Cawley Road Overbridge will be conducted at the completion of Longwall 304 and Longwall 307 or otherwise if determined in consultation with the Technical Committee.

## 7.5 ROAD WORKS

The following monitoring will be undertaken during the mining of Longwalls 305-307.

### 7.5.1 Ground Monitoring

The M1 Princes Motorway Northbound monitoring line will be surveyed within 3 months following the completion of each longwall. The Technical Committee will analyse data from other monitoring lines to assist in assessing the requirement for increased monitoring frequency of the Northbound Line. Otherwise the frequency of ground monitoring lines is as follows:

- M1 Princes Motorway (Northbound Line): prior to Longwall 305, and after the completion of each longwall<sup>7</sup>.
- Cross line (300 XL Line): prior to Longwall 305, and after the completion of each of Longwall.
- Real time absolute 3D monitoring at GNSS stations located between the motorway and Longwall 301.

### 7.5.2 TFNSW Road Mounted Monitoring Systems and Visual Monitoring

The pavement condition will be assessed from data obtained using the TFNSW RoadCrack, Gipsicam and Laser Profilometer pavement assessment systems in accordance with the TFNSW inspection program. More frequent assessments would be conducted if determined in consultation with the Technical Committee.

A site inspection of the pavement, kerbs and gutters, pits, signs and other road infrastructure will be carried out by the TFNSW following the completion of each longwall or more frequently if determined in consultation with the Technical Committee.

Regular visual inspections will be conducted during mining by representatives of the TFNSW as part of the TFNSW Network Safety Inspections. These inspections are carried out by a dedicated inspector twice weekly and any observed defects that represent a safety hazard will be reported to the Technical Committee.

### 7.5.3 Cuttings

It was agreed by the Technical Committee that the risk of impacts to the cuttings and embankments along the M1 Princes Motorway was very low and slopes will be treated only when a change in their condition is noted.

<sup>7</sup> M1 Motorway ground monitoring points were discontinued during Longwall 306 after monthly monitoring reports for Longwalls 305 and 306 continually showed survey results within nominated triggers. It was considered reasonable by the Technical Committee to discontinue with the terrestrial monitoring method following resheeting of M1 in this area and replace with remote GNSS monitoring of higher accuracy at key locations along the corridor.

Visual monitoring is undertaken to assess potential movement and or impacts to the cuttings. A site inspection of the cuttings will be conducted following the completion of each longwall, or more frequently if determined in consultation with the Technical Committee. The site inspection will be conducted by representative(s) from the TFNSW If, following any cutting inspection, there are any observable changes in the cutting face, a further risk assessment of that cutting is to be carried out. Treatment, if required will be based on the revised risk assessment. After completion of the treatment the cutting will be rated in accordance with the TFNSW Guide to Slope Risk Analysis (TFNSW, 2014).

Real time survey information is collected from the adjacent Transmission GNSS Sites. This survey data along with visual inspections are reviewed by the Technical Committee geotechnical and mining engineering specialists to assess the need for a survey of the M1 Northbound Line or an inspection of the cuttings. The Technical Committee, may as a result of the review, determine that survey of all or part of the M1 Northbound Line be carried out or that inspections be carried on some or all of the cuttings.

Regular visual inspections will be conducted during mining by representatives of the TFNSW as part of the TFNSW Network Safety Inspections. These inspections are carried out by a dedicated inspector twice weekly and any observed defects that represent a safety hazard will be reported to the Technical Committee.

#### 7.5.4 Culverts

TFNSW will conduct a site inspection of the culverts (using CCTV) following the completion of Longwall 311, i.e. at five times depth of cover or 2.5 km from the culverts or more frequently if determined in consultation with the Technical Committee. The inspection will include:

- recording of existing cracks;
- recording of other defects and general condition;
- two dimensional image records of the affected structures; and
- condition of the access roads with specific attention to surface cracks.

#### 7.6 MONITORING PROGRAM

The monitoring outlined above in this Section will be implemented to monitor the impacts of the Project on the TFNSW assets. Table 9 summarises the BFMP-TFNSW monitoring components.

Metropolitan Coal –305 - 307 Built Features Management Plan – Transport for NSW		
Revision No. BFMP_TFNSW-R01-D	ME-TSE-MNP-0088	Page 39
Document ID: Built Features Management Plan - TfNSW		

**Table 9**  
**BFMP-TFNSW Monitoring Program Overview**

Program	Aspect	Method	How	Why	Timing	Frequency
Baseline	Ground	Survey	Adjacent subsidence line points at approximately 20 m spacing	Establish base conditions	Prior to Longwall 301 extraction	Completed
	Bridge 2 (Old Princes Highway Underpass)	FBG	Changes in length of FBG sensors and tilts of FBG tiltmeters	To determine the range of movements due to environmental effects, (diurnal and seasonal).	Program of varying (diurnal and seasonal) sampling rates.	
	Cawley Road Overbridge	Survey (Absolute)	Survey reference pillar	Establish base condition	Prior to Longwall 301 extraction	Completed
		Survey (Relative 3D)	Survey all bridge monitoring points	Establish base condition	Prior to Longwall 301 extraction	Completed
	Transmission Towers & Bridges	GNSS (Absolute)	Real time continuous monitoring at GNSS Sites 3, 4, 5, 6, 8, & 9	Establish base conditions	Longwall 301 extraction	Completed
	Cuttings	Condition Report (visual inspection)	Cuttings along the M1 Princes Motorway as described in Table 7 and shown on Figure 5	Establish base condition	Prior to Longwall 301 extraction	Completed
	Culverts	Condition Report		Establish base condition	Prior to Longwall 301 extraction	Completed
	Pavement and Other	Condition Report (visual inspection)	Asphaltic concrete surface	Establish base condition	Prior to Longwall 301 extraction	Completed
Kerbs, gutters and pits			Establish base condition	Prior to Longwall 301 extraction	Completed	
Signs or other road infrastructure			Establish base condition	Prior to Longwall 301 extraction	Completed	

Note: Baseline monitoring of all TFNSW assets will be carried out as outlined in Section 6.

**Table 9 (Continued)**  
**BFMP-TFNSW Monitoring Program Overview**

Program	Aspect	Method	How	Why	Timing	Frequency
During Mining	Ground	Survey	M1 subsidence line points at approximately 20 m spacing	Monitor subsidence effects during mining (subsidence, tilt, tensile strain, compressive strain, horizontal movement)	At the completion of Longwalls 305 and 306 or earlier if agreed by Technical Committee	Once per Longwall 305, 306
	Bridge 2 (Old Princes Highway Underpass)	GNSS (Absolute 3D)	Absolute 3D movement at GNSS site #3 (Section 7.3.3)	To measure absolute ground movement and hence potential for relative movement of bridge elements	Real-time (continuous) monitoring	Daily measurement
						Monthly reporting to Technical Committee
		Survey (Relative 3D)	Relative 3D movements of all bridge monitoring points	To measure distortion of structure	If GNSS#3 records absolute movement greater than 50mm	If triggered by GNSS unit then weekly until TC agrees frequency
		FBG	Changes in length of FBG sensors and tilts of FBG tiltmeters	To measure distortion of structure	From commencement of Longwall 305 to midpoint of Longwall 306	Weekly measurements with quarterly reporting to Technical Committee for the stated longwalls
	Visual Inspection for impacts on:		To identify development of, or changes in existing:	At the completion of Longwall 307	Greater frequency if determined in consultation with the Technical Committee	
<ul style="list-style-type: none"> <li>• Abutments.</li> <li>• Pier frames.</li> <li>• Elastomeric bearings.</li> <li>• Soffits of girders.</li> <li>• Deck expansion joints.</li> <li>• Steel traffic barrier joints.</li> <li>• Other areas of substructure and adjoining areas including concrete paths, stairs, and slope protection.</li> </ul>						
Cawley Road Overbridge	GNSS (Absolute 3D)	Absolute 3D movement of GNSS Site #9 (Section 7.4.2)	To measure absolute ground movement and hence potential for relative movement of bridge elements	Real-time (continuous) monitoring	Daily measurement	
					Monthly reporting to Technical Committee	

**Table 9 (Continued)**  
**BFMP-TFNSW Monitoring Program Overview**

Program	Aspect	Method	How	Why	Timing	Frequency
During Mining (Cont.)	Cawley Road Overbridge (Cont.)	Survey (Relative 3D)	Relative 3D movements of all bridge monitoring points	To measure distortion of structure	At the completion of Longwalls 305 and 306 or earlier if agreed by Technical Committee	Once per Longwalls 305 and 306
		Visual inspection for impacts on: <ul style="list-style-type: none"> <li>Abutments.</li> <li>Pier blade wall.</li> <li>Tetron bearings.</li> <li>Deck expansion joints.</li> <li>Steel traffic barrier and safety screen joints.</li> </ul>	To identify development of, or changes in existing: <ul style="list-style-type: none"> <li>Surface cracks.</li> <li>Closing or opening of joints.</li> <li>Distortion or damage to Tetron bearings.</li> </ul>	At the completion of Longwall 309 (2.5 km away from Cawley Road Bridge)	Greater frequency if determined in consultation with the Technical Committee	
	Cuttings	Visual inspection for impacts on: <ul style="list-style-type: none"> <li>Cuttings along the M1 Princes Motorway as described in Table 7 and shown on Figure 5.</li> </ul>	To identify: <ul style="list-style-type: none"> <li>Changes in cutting condition, including opening of cracks, spalling.</li> <li>Changes in groundwater seepage or surface water flows.</li> <li>Rockfalls.</li> <li>Changes in TFNSW risk ranking.</li> </ul>	At the completion of Longwall 307	Greater frequency if determined in consultation with the Technical Committee	
		Network Safety Inspection (TFNSW)		During the extraction of Longwalls 305, 306 and 307	Twice Weekly	

**Table 9 (Continued)**  
**BFMP-TFNSW Monitoring Program Overview**

Program	Aspect	Method	How	Why	Timing	Frequency
<b>During Mining (Cont.)</b>	Culverts	CCTV inspection for impacts on internal surfaces		To identify changes to the visible surfaces of the culverts including cracking, buckling, shearing, and collapse	At the completion of Longwall 310 (2.25 km away from culverts)	
					More frequent if determined in consultation with the Technical Committee	
	Pavement and Other	Visual inspection for impacts on: <ul style="list-style-type: none"> <li>Asphaltic concrete surface.</li> <li>Kerbs, gutters and pits.</li> <li>Signs or other road infrastructure.</li> </ul>		To identify development of, or changes in existing: <ul style="list-style-type: none"> <li>Asphaltic concrete surface including cracks, buckling and stepping.</li> <li>Kerbs and gutters including cracking, buckling and joint movement.</li> </ul>	At the completion of Longwall 307 around defect at FW 217.15	Once
						More frequent if determined in consultation with the Technical Committee
					Network Safety Inspection (TFNSW)	During the extraction of Longwalls 305, 306, and 307
	RoadCrack, Gipsicam and Laser Profilometer pavement assessment systems (TFNSW)	TFNSW inspection program				
<b>Post Mining</b>	Bridge 2 (Old Princes Highway Underpass)	Condition Report		Determine level of impact of mining (if any)	Within 3 months of the completion of Longwall 307 (or as otherwise agreed by the Technical Committee)	Once
	Cawley Road Overbridge	Condition Report		Determine level of impact of mining (if any)	Within 3 months of the completion of Longwall 307 (or as otherwise agreed by the Technical Committee)	Once

The frequency of monitoring will be reviewed either:

- in accordance with the Annual Review outlined in Section 12; or
- if triggered as a component of the Contingency Plan as outlined in Section 9.

## 7.7 SUBSIDENCE PARAMETERS

### 7.7.1 Ground Monitoring

Subsidence parameters (i.e. subsidence, tilt, tensile strain, and compressive strain) associated with ground movement will be measured in accordance with the Longwalls 305-307 SMP. The ground monitoring locations are illustrated in Figure 6.

In summary, surveys will be conducted to measure subsidence movements in three dimensions using a total station survey instrument. Subsidence parameters (i.e. subsidence, tilt, tensile strain and compressive strain) will be calculated along subsidence lines that have been positioned across the general landscape, including:

- M1 Princes Motorway (Northbound Line); and
- Cross line (300 XL).

With the exception of the direct survey of subsidence parameters along the M1 Princes Motorway, the subsidence parameters obtained from other ground monitoring surveys will be used for assessment of potential subsidence movements at the bridges or along the M1 Princes Motorway road pavement.

Automated continuous GNSS monitoring of the adjacent 330 kV transmission towers are carried out during mining and data from this monitoring system will be considered in the review of subsidence movements nearby the M1 Princes Motorway. The Technical Committee, may as a result of the review, direct that survey of all or part of the M1 Northbound Line be carried out or that inspections be carried on some or all of the cuttings.

### 7.7.2 Bridge Monitoring

Bridge monitoring parameters are the potential distortional movements within the bridge structure resulting from the extraction of Longwalls 305-307. The monitoring systems to measure these parameters include surveying of targets fixed to key points on the bridges, and FBG sensors (extensometers and tiltmeters) for Bridge 2 only. These are described in 7.2 to 7.4 above.

Metropolitan Coal has installed real-time survey monitoring as an additional management tool that tracks absolute movements on a continuous basis at both bridges. The real-time data has been validated by the Technical Committee during the mining of Longwall 301 and 302 to provide information on the absolute movement of the ground nearby each bridge and inform the decision for other higher frequency monitoring.

Metropolitan Coal –305 - 307 Built Features Management Plan – Transport for NSW		
Revision No. BFMP_TFNSW-R01-D	ME-TSE-MNP-0088	Page 44
Document ID: Built Features Management Plan - TfNSW		

## 7.8 SUBSIDENCE IMPACTS

### 7.8.1 Bridge Impacts

It is generally not possible to assess the impacts of relative ground movements on the bridges directly from the distortions of the bridges measured by the monitoring systems. This is because the ground movements could cause unacceptable stresses well before the effects of those stresses become visible. The pre-existing stresses in bridge elements from permanent loads (self weight etc) combined with those from relative ground movements may not be sufficient to cause an “overstress”. However, the addition of stresses from other transient loads and effects (vehicle loading, braking, wind, temperature, etc.) that could be applied at any time may be sufficient to instantly cause an overstress and so must be taken into account.

The method of assessing the impacts of relative ground movements on bridges is to carry out a structural analysis of the bridge using computer modelling. The distortions of the structure from ground movement, measured using the monitoring systems, are applied in those structural models to determine the component of total stress at each critical location in the structure that is due to relative ground movement. The analysis will determine stress magnitudes at various locations from permanent loads, relative ground movement and future transient effects.

The analysis can therefore determine when the effects of relative ground movement are reaching permissible limit such that the combined stress from all three load types (pre-existing, ground movements and future transient) are combined. It may be necessary to take action to prevent unacceptable impacts on the bridge well before any impact is visible, and this will be determined in consultation with the Technical Committee following its consideration of the structural analysis outcome of relative movements on Bridge 2.

Visual inspections of the bridge structures will be conducted by representative(s) from the TfNSW and the Technical Committee (e.g. Cardno) to assess any defects that have apparently resulted from the ground movements due to extraction of Longwalls 305-307.

For Bridge 2, inspections will include the following bridge elements and areas:

- visible surfaces of abutments – front and top surfaces of abutment headstocks, inside face of curtain walls where visible and faces of blade walls at the junction with the headstock (where they are exposed);
- visible surfaces of pier frames – all faces of each column (above ground) and four sides of headstock;
- elastomeric bearings at the abutments and piers;
- soffits of girders around the bearings at piers (where excessive force from dowels would result in cracking); and
- deck expansion joints and steel traffic barrier joints at the abutments.

Other areas of the substructure should also be inspected generally with particular attention to locations where the substructure abuts and is hard against rigid pavement, concrete stairs and slope protection, etc.

For Cawley Road Overbridge, inspections will include the following bridge elements and areas:

- visible surfaces of abutments;
- visible surfaces of pier blade wall;

Metropolitan Coal – 305 - 307 Built Features Management Plan – Transport for NSW		
Revision No. BFMP_TFNSW-R01-D	ME-TSE-MNP-0088	Page 45
Document ID: Built Features Management Plan - TfNSW		

- Tetron bearings at the abutments; and
- deck expansion joints and steel traffic barrier joints at the abutments.

### 7.8.2 Pavement Impacts

In addition to monitoring of subsidence parameters for the M1 Princes Motorway road pavement, subsidence impacts will be assessed along the pavement using the TFNSW RoadCrack, Gipsicam and Laser Profilometer pavement assessment systems.

Visual inspections of the road pavement, kerbs and gutters, pits, signs and other road infrastructure will be carried out by representative(s) from the TFNSW to assess changes from the baseline condition as a result of the extraction of Longwalls 305-307. Twice weekly drive through visual inspections will also be conducted as part of the TFNSW Network Safety Inspections with particular focus on impacts in the vicinity of the faults.

Subsidence impacts will be monitored using the above methods for both carriageways of the pavement extending from Bridge 2 to Cawley Road Overbridge.

### 7.8.3 Impacts to Cuttings

Visual monitoring would be undertaken to assess potential movement and/or impacts to the cuttings resulting from the extraction of Longwalls 305-307. Twice weekly drive through visual inspections will also be conducted as part of the TFNSW Network Safety Inspections.

If, following any cutting inspection, there are any observable changes in the cutting face, a further risk assessment of that cutting is to be carried out. Treatment, if required will be based on the revised risk assessment. After completion of the treatment the cutting will be rated in accordance with the RMS Guide to Slope Risk Analysis (RMS, 2014).

### 7.8.4 Impacts to Culverts

Visual inspection of the culverts will be carried out using CCTV to provide an assessment of the condition of the culverts. The inspection will be carried out by representative(s) from the TFNSW. The inspection will include:

- recording of existing cracks;
- recording of other defects and general condition;
- video records of the affected structures; and
- condition of the access roads with specific attention to surface cracks.

## 7.9 ENVIRONMENTAL CONSEQUENCES

Metropolitan Coal and TFNSW will compare the results of the subsidence impact monitoring against the built features performance indicators. In the event that the observed subsidence impacts exceed the performance indicators, Metropolitan Coal and TFNSW will assess the consequences of the exceedance in accordance with the management measures outlined in Section 8. In the event that the performance measures are exceeded or are considered likely to be exceeded in the absence of contingent actions, then the Contingency Plan described in Section 9 will be implemented.

Metropolitan Coal – 305 - 307 Built Features Management Plan – Transport for NSW		
Revision No. BFMP_TFNSW-R01-D	ME-TSE-MNP-0088	Page 46
Document ID: Built Features Management Plan - TfNSW		

## 8 MANAGEMENT MEASURES

### 8.1 GENERAL

A number of general management measures in relation to TFNSW assets are applicable. These include:

- review of scope and frequency of monitoring;
- site inspections;
- review by relevant specialists;
- initiate traffic management procedures;
- review of the potential factors contributing to the exceedance of the performance trigger including review of subsidence measurements and predictions; and
- review effectiveness of management measures.

### 8.2 BRIDGES

Potential management measures that can be implemented for Bridge 2 and Cawley Road Overbridge include repair of cracked elements where the crack width is within the acceptable limit. This can be carried out after ground movements due to mining have ceased as their presence during mining does not affect to safe operation of the bridge.

At Cawley Road Overbridge, replacement of guided sliding bearings at abutments could also be carried out.

### 8.3 ROAD PAVEMENTS

A number of potential management measures in relation to the M1 Princes Motorway pavement are considered to be applicable. These include:

- mill and replace pavement layers;
- slotting; and
- crack sealing.

During the risk assessment conducted for Longwalls 301-303, it was also noted that the planned re-surfacing of the carriageway by TFNSW to remediate general road use wear and tear would be able to be scheduled after Longwall 303, which would provide an opportunity to remediate the road if any pavement damage was caused by the mining activities, as well as general road use wear and tear. Monitoring during and after the completion of mining Longwall 304 did not identify any pavement damage. It is anticipated that the planned re-surfacing will proceed 2021, however the timing may be subject to change and will be determined by the TFNSW.

### 8.4 CUTTINGS

A number of potential management measures in relation to cuttings are considered to be applicable. These include:

- rock bolting;

Metropolitan Coal – 305 - 307 Built Features Management Plan – Transport for NSW		
Revision No. BFMP_TFNSW-R01-D	ME-TSE-MNP-0088	Page 47
Document ID: Built Features Management Plan - TfNSW		

- scaling;
- shotcreting;
- installation of rockfall mesh;
- installation of barriers; and
- trimming of the cut face.

## 8.5 CULVERTS

A number of potential management measures in relation to culverts are considered to be applicable. These include:

- point repairs;
- lining;
- grouting; and
- culvert replacement.

## 9 CONTINGENCY PLAN

In the event that the observed subsidence parameters or impacts exceed or are considered likely to exceed the performance measures detailed in Section 5 of this BFMP-TFNSW, Metropolitan Coal will implement the following Contingency Plan (Appendix 9):

- The observation will be reported to the Metropolitan Coal Technical Services Manager within 24 hours.
- The observation will be recorded in the Built Features Management Plan – Subsidence Impact Register (Appendix 8) consistent with the monitoring program described in Section 7 of this BFMP-TFNSW.
- Metropolitan Coal will report any exceedance of the performance measure to the DPIE and the TFNSW as soon as practicable after Metropolitan Coal becomes aware of the exceedance.
- Metropolitan Coal and the TFNSW will assess public safety and where appropriate implement safety measures in accordance with the Metropolitan Coal Longwalls 305-307 Public Safety Management Plan and the NSW *Road Transport Act 2013*.
- Metropolitan Coal will conduct an investigation to evaluate the potential contributing factors. The investigation will:
  - include the re-survey of relevant subsidence monitoring lines;
  - compare and critically analyse measured versus predicted subsidence parameters;
  - review measured subsidence parameters against the observed impact; and
  - review the SMP and update the program where appropriate.
- Metropolitan Coal will identify an appropriate course of action with respect to the identified impact(s), in consultation with specialists, relevant agencies, and the TFNSW. For example:
  - proposed contingency measures;
  - a program to review the effectiveness of the contingency measures; and

Metropolitan Coal –305 - 307 Built Features Management Plan – Transport for NSW		
Revision No. BFMP_TFNSW-R01-D	ME-TSE-MNP-0088	Page 48
Document ID: Built Features Management Plan - TfNSW		

- consideration of modification to the mine layout under circumstances where unacceptable impacts to the bridges or pavements would otherwise be unmanageable.
- Contingency measures will be developed in consideration of the specific circumstances of the issue and the assessment of consequences. Contingency measures include those described in Section 8 and Section 9.1.
- Metropolitan Coal will submit the proposed course of action to the DPIE for approval.
- Metropolitan Coal will implement the approved course of action to the satisfaction of the DPIE.

In accordance with Condition 6, Schedule 6 of the Project Approval, Metropolitan Coal will provide a suitable offset to compensate for the impact to the satisfaction of the Secretary of DPIE if either the contingency measures implemented by Metropolitan Coal have failed to remediate the impact or the Secretary determines that it is not reasonable or feasible to remediate the impact.

### 9.1 CONTINGENCY MEASURES

Contingency measures will be developed in consideration of the specific circumstances of the feature (e.g. the location, nature and extent of the impact, and the assessment of environmental consequences).

Contingency measures that could be considered in the event that the performance measure for the relevant asset is exceeded (e.g. damaged beyond repair) are summarised in Table 10. The decision trees for the contingency measures are shown in Appendix 9.

In the remote event traffic diversions are required due to subsidence impacts, an alternate travel route along the Old Princes Highway may be available (subject to consultation and agreement with Wollongong City Council). This route may therefore be available for the period required to effect such contingency measures summarised in Table 10.

**Table 10  
Contingency Measures – TFNSW Assets**

Environmental Consequence	Contingency Measures	
	Measure	Description
General	-	<ul style="list-style-type: none"> <li>• Reconfigure mining geometry.</li> <li>• Reduce rate of extraction.</li> </ul>
Impact on:		
Bridges	Replace bridge.	<ul style="list-style-type: none"> <li>• Complete replacement of the bridge with a new bridge structure.</li> <li>• Erect temporary bridge.</li> <li>• Staged replacement.</li> </ul>
	Stabilise bridge.	<ul style="list-style-type: none"> <li>• Erect temporary bridge props/supports.</li> <li>• Contraflow arrangements using one of the two bridges.</li> </ul>
M1 Princes Motorway road pavement	Major repairs.	<ul style="list-style-type: none"> <li>• Major reconstruction of a section of the motorway.</li> </ul>
Cuts and Fills	Stabilisation measures.	<ul style="list-style-type: none"> <li>• Reconstruct the cutting or fill.</li> </ul>
Culverts	Replacement.	<ul style="list-style-type: none"> <li>• Reconstruct the culvert.</li> </ul>

## 10 TARP – MANAGEMENT TOOL

The framework for the various components of the BFMP-TFNSW are summarised in the BFMP-TFNSW Trigger Action Response Plans (TARPs) shown in Tables 11 to 15. The BFMP-TFNSW TARPs illustrate how the various predicted subsidence impacts, monitoring components, performance measures, and responsibilities are structured to achieve compliance with the relevant statutory requirements, and the framework for management and contingency actions.

The TARP comprises:

- baseline conditions;
- predicted subsidence impacts;
- trigger levels from monitoring to assess performance; and
- triggers that flag implementation of contingency measures.

The TARP system provides a simple and transparent snapshot of the monitoring of environmental performance and the implementation of management and/or contingency measures.

Metropolitan Coal –305 - 307 Built Features Management Plan – Transport for NSW		
Revision No. BFMP_TFNSW-R01-D	ME-TSE-MNP-0088	Page 50
Document ID: Built Features Management Plan - TfNSW		

**Table 11**  
**Trigger Action Response Plan – Bridge 2 (Old Princes Highway Underpass)**

TFNSW – Bridge 2 (Old Princes Highway Underpass)	
<i>Risk: Subsidence effect on bridge structure resulting in impact to structural integrity.</i>	
TRIGGER LEVEL	RESPONSE
<b>Level 1 - Normal</b>	
<b>Expected subsidence conditions due to Longwalls</b>	
Absolute Horizontal Movements <ul style="list-style-type: none"> <li>less than 95 mm*</li> </ul> Structural cracks less than 0.1 mm	<p><b><u>Normal Operations</u></b></p> <ul style="list-style-type: none"> <li>Bridge is safe and serviceable.</li> <li>Negligible impact to bridge structure.</li> <li>Continue monitoring activities as planned.</li> </ul> <p><b><u>Metropolitan Coal</u></b></p> <p>* Weekly survey monitoring to commence upon greater than 50 mm absolute horizontal movement at GNSS#3.</p>
<b>Level 2 - Monitor</b>	
<b>Subsidence due to Longwalls 305 to 307 more than predicted (e.g. beyond survey tolerance) and up to 1 in ~100 probability, but bridge condition normal</b>	
Absolute Horizontal Movements <ul style="list-style-type: none"> <li>between 95 and 105 mm</li> </ul> Structural cracks less than 0.1 mm	<p><b><u>Conditions: Continue operations but report on subsidence anomaly</u></b></p> <ul style="list-style-type: none"> <li>Bridge is safe and serviceable.</li> <li>Impact on bridge structure is within tolerable limits or no credible consequences.</li> </ul>
	<p><b><u>Metropolitan Coal (actions as required)</u></b></p> <ul style="list-style-type: none"> <li>Resurvey subsidence line, ground points to confirm results, and that the results are consistent with other subsidence lines.</li> <li>Inform and provide the report on subsidence results to TFNSW, NSW Principal Subsidence Engineer and Subsidence Advisory NSW.</li> </ul>
	<p><b><u>Timing / Frequency</u></b></p> <ul style="list-style-type: none"> <li>Within 3 days.</li> <li>Within 7 days.</li> </ul>
	<p><b><u>TFNSW (Technical Committee)</u></b></p> <ul style="list-style-type: none"> <li>Technical Committee subsidence specialists to review monitoring data and assess results for trends, and forecast when the Level 3 trigger might be exceeded.</li> <li>Technical Committee to consider whether:                             <ul style="list-style-type: none"> <li>to increase the frequency of survey and site inspections; and</li> <li>any mitigation measures or additional management measures are required to avoid exceeding the Level 3 trigger.</li> </ul> </li> </ul>
	<p><b><u>Timing / Frequency</u></b></p> <ul style="list-style-type: none"> <li>Within 7 days.</li> <li>Within 7 days.</li> </ul>

**Table 11 (Continued)**  
**Trigger Action Response Plan – Bridge 2 (Old Princes Highway Underpass)**

TFNSW – Bridge 2 (Old Princes Highway Underpass)		
<i>Risk: Subsidence effect on bridge structure resulting in impact to structural integrity.</i>		
TRIGGER LEVEL	RESPONSE	
<b>Level 3 - Cautionary</b>		
<b>Anomalous differential bridge movement or subsidence beyond +15% of predicted or exceedance of nominated 1 in ~100 probability</b>		
TFNSW – Bridge 2 (Old Princes Highway Underpass)	Absolute Horizontal Movements	<p><b><u>Conditions: Investigate &amp; Resolve</u></b></p> <ul style="list-style-type: none"> <li>• Bridge is safe and serviceable.</li> <li>• Indication of impact to bridge structure including structural cracks between 0.1 mm and 1.0 mm width.</li> <li>• Works to affect Old Princess Highway, not the M1 Motorway.</li> </ul>
	<ul style="list-style-type: none"> <li>• greater than 105 mm at the base</li> </ul>	
	Observable subsidence ground deformations at the bridge	<p><b><u>Metropolitan Coal (actions as required)</u></b></p> <ul style="list-style-type: none"> <li>• Notify TFNSW, NSW Principal Subsidence Engineer, Subsidence Advisory NSW, and the Technical Committee that survey results show the trigger was exceeded and provide a report on the subsidence results.</li> <li>• Provide a report to the NSW Principal Subsidence Engineer on how the Level 3 situation is being managed to keep the bridge safe and serviceable.</li> </ul>
	Structural cracks between 0.1 mm and 1.0 mm width	
	<p><b><u>Timing / Frequency</u></b></p> <ul style="list-style-type: none"> <li>• Within 24 hours.</li> <li>• Within 2 weeks.</li> </ul>	
	<p><b><u>TFNSW (Works Supervisor)</u></b></p> <ul style="list-style-type: none"> <li>• Inspect and assess condition of bridge at trigger point and general area, determine if any remedial action required, and advise Technical Committee.</li> </ul>	<p><b><u>Timing / Frequency</u></b></p> <ul style="list-style-type: none"> <li>• Within 4 hours of notification.</li> </ul>
	<p><b><u>TFNSW (Technical Committee)</u></b></p> <ul style="list-style-type: none"> <li>• Technical Committee subsidence specialists to review monitoring data and assess results for trends, and forecast when the Level 4 trigger might be reached.</li> <li>• Technical Committee to consider whether to:                             <ul style="list-style-type: none"> <li>○ increase survey and/or inspection frequencies;</li> <li>○ take any mitigation/additional management measures, including erecting temporary bridge props/supports or bringing forward the end-of-panel position, to avoid reaching the Level 4 trigger;</li> <li>○ employ a dedicated Inspector on site on full time basis; and/or</li> <li>○ suggest the need for a speed restriction or traffic diversions to TFNSW, and implement decisions following TFNSW and Metropolitan Coal concurrence.</li> </ul> </li> </ul>	<p><b><u>Timing / Frequency</u></b></p> <ul style="list-style-type: none"> <li>• Within 3 days.</li> <li>• Within 5 days.</li> </ul>

**Table 11 (Continued)**  
**Trigger Action Response Plan – Bridge 2 (Old Princes Highway Underpass)**

TFNSW – Bridge 2 (Old Princes Highway Underpass)			
<i>Risk: Subsidence effect on bridge structure resulting in impact to structural integrity.</i>			
TRIGGER LEVEL	RESPONSE		
<b>Level 4 – Restoration</b> <b>Exceedance of nominated 1 in ~2000 probability or fault occurs</b>			
TFNSW – Bridge 2 (Old Princes Highway Underpass)	Structural cracks greater than 1.0 mm width	<b><u>Implement Contingency Plan</u></b> <ul style="list-style-type: none"> <li>As per BFMP Section 9 and Appendix 9.</li> </ul>	
		<b><u>Metropolitan Coal (actions under the circumstances)</u></b> <ul style="list-style-type: none"> <li>Notify TFNSW, NSW Principal Subsidence Engineer, Subsidence Advisory NSW, and the Technical Committee of the Level 4 situation.</li> </ul>	<b><u>Timing / Frequency</u></b> <ul style="list-style-type: none"> <li>Within 2 hours.</li> </ul>
		<b><u>TFNSW (Works Supervisor)</u></b> <ul style="list-style-type: none"> <li>Notify TFNSW Traffic Commander via Transport Management Centre to immediately apply speed restriction. Phone 131 700</li> <li>Inspect and assess condition of bridge at trigger point and general area, initiate any remedial action as required, and advise Technical Committee.</li> </ul>	<b><u>Timing / Frequency</u></b> <ul style="list-style-type: none"> <li>Immediately upon notification. Phone 131 700 Transport Management Centre</li> <li>Immediate callout and arrive within 2 hours.</li> </ul>
		<b><u>TFNSW (Traffic Commander) and NSW Police</u></b> <ul style="list-style-type: none"> <li>TFNSW Traffic Commander and NSW Police apply and enforce speed restriction, and determine if a detour is necessary.</li> </ul>	<b><u>Timing / Frequency</u></b> <ul style="list-style-type: none"> <li>Immediate callout and arrive within 2 hours.</li> </ul>
		<b><u>TFNSW (Technical Committee)</u></b> <ul style="list-style-type: none"> <li>Technical Committee to review monitoring data and consider whether to:                             <ul style="list-style-type: none"> <li>increase survey and/or inspection frequencies;</li> <li>take any additional management measures, including erecting temporary bridge props/supports or bringing forward the end-of-panel position; and/or</li> <li>suggest the need for mining to be temporarily halted (if unacceptable to TFNSW);</li> </ul> </li> </ul> and implement decisions following TFNSW and Metropolitan Coal concurrence.	<b><u>Timing / Frequency</u></b> <ul style="list-style-type: none"> <li>Within 3 days.</li> </ul>

**Table 12**  
**Trigger Action Response Plan – Cawley Road Overpass**

TFNSW – Cawley Road Overpass		
<i>Risk: Subsidence effect on bridge structure resulting in impact to structural integrity.</i>		
TRIGGER LEVEL	RESPONSE	
<b>Level 1 - Normal</b>		
<b>Expected subsidence conditions due to Longwalls</b>		
Absolute Horizontal Movements <ul style="list-style-type: none"> <li>less than 20 mm</li> </ul>	<p><b><u>Normal Operations</u></b></p> <ul style="list-style-type: none"> <li>Bridge is safe and serviceable.</li> <li>Negligible impact to bridge structure.</li> <li>Continue monitoring activities as planned.</li> </ul> <p><b><u>Metropolitan Coal</u></b></p> <ul style="list-style-type: none"> <li>* Weekly survey monitoring to commence upon greater than 30 mm absolute horizontal movement at GNSS#9.</li> </ul>	
<b>Level 2 - Monitor</b>		
<b>Subsidence more than predicted (e.g. beyond survey tolerance) or 1 in ~100 probability exceedance, but bridge condition normal</b>		
Absolute Horizontal Movements <ul style="list-style-type: none"> <li>between 20 and 30 mm</li> </ul>	<p><b><u>Conditions: Continue operations but report on subsidence anomaly</u></b></p> <ul style="list-style-type: none"> <li>Bridge is safe and serviceable.</li> <li>Impact on bridge structure is within tolerable limits.</li> </ul>	
Structural cracks less than 0.1 mm	<p><b><u>Metropolitan Coal (actions as required)</u></b></p> <ul style="list-style-type: none"> <li>Resurvey bridge points to confirm results.</li> <li>Inform and provide the report on subsidence results to TFNSW, NSW Principal Subsidence Engineer and Subsidence Advisory NSW.</li> </ul>	<p><b><u>Timing / Frequency</u></b></p> <ul style="list-style-type: none"> <li>Within 3 days.</li> <li>Within 7 days.</li> </ul>
	<p><b><u>TFNSW (Technical Committee)</u></b></p> <ul style="list-style-type: none"> <li>Technical Committee subsidence specialists to review monitoring data and assess results for trends, and forecast when the Level 3 trigger might be exceeded.</li> <li>Technical Committee to consider whether:                             <ul style="list-style-type: none"> <li>to increase the frequency of survey and site inspections; and</li> <li>any mitigation measures or additional management measures are required to avoid exceeding the Level 3 trigger.</li> </ul> </li> </ul>	<p><b><u>Timing / Frequency</u></b></p> <ul style="list-style-type: none"> <li>Within 7 days.</li> <li>Within 7 days.</li> </ul>

**Table 12 (Continued)**  
**Trigger Action Response Plan – Cawley Road Overpass**

TFNSW – Cawley Road Overpass			
<i>Risk: Subsidence effect on bridge structure resulting in impact to structural integrity.</i>			
TRIGGER LEVEL	RESPONSE		
<b>Level 3 - Cautionary</b>			
<b>Anomalous differential bridge movement or subsidence beyond +15% of predicted or exceedance of nominated 1 in ~100 probability</b>			
TFNSW – Cawley Road Overpass	Absolute Horizontal Movements	<b>Conditions: Investigate &amp; Resolve</b>	
	<ul style="list-style-type: none"> <li>greater than 30 mm</li> </ul>	<ul style="list-style-type: none"> <li>Bridge is safe and serviceable.</li> </ul>	
	Observable subsidence ground deformations at the bridge	<ul style="list-style-type: none"> <li>Indication of impact to bridge structure including structural cracks between 0.1 mm and 1.0 mm width.</li> </ul>	
	If M1 Motorway absolute horizontal movement greater than 30 mm within 400 m of bridge	<b>Metropolitan Coal (actions as required)</b>	<b>Timing / Frequency</b>
	Structural cracks between 0.1 mm and 1.0 mm width	<ul style="list-style-type: none"> <li>Notify TFNSW, NSW Principal Subsidence Engineer, Subsidence Advisory NSW, and the Technical Committee that survey results show the trigger was exceeded and provide a report on the subsidence results.</li> <li>Provide a report to the NSW Principal Subsidence Engineer on how the Level 3 situation is being managed to keep the bridge safe and serviceable.</li> </ul>	<ul style="list-style-type: none"> <li>Within 24 hours.</li> <li>Within 2 weeks.</li> </ul>
		<b>TFNSW (Works Supervisor)</b>	<b>Timing / Frequency</b>
	<ul style="list-style-type: none"> <li>Inspect and assess condition of bridge at trigger point and general area, determine if any remedial action required, and advise Technical Committee.</li> </ul>	<ul style="list-style-type: none"> <li>Within 4 hours of notification.</li> </ul>	
	<b>TFNSW (Technical Committee)</b>	<b>Timing / Frequency</b>	
	<ul style="list-style-type: none"> <li>Technical Committee subsidence specialists to review monitoring data and assess results for trends, and forecast when the Level 4 trigger might be reached.</li> <li>Technical Committee to consider whether to:                             <ul style="list-style-type: none"> <li>increase survey and/or inspection frequencies;</li> <li>take any mitigation/additional management measures, including erecting temporary bridge props/supports or bringing forward the end-of-panel position, to avoid reaching the Level 4 trigger;</li> <li>employ a dedicated Inspector on site on full time basis; and/or</li> <li>suggest the need for a speed restriction or traffic diversions to TFNSW, and implement decisions following TFNSW and Metropolitan Coal concurrence.</li> </ul> </li> </ul>	<ul style="list-style-type: none"> <li>Within 3 days.</li> <li>Within 5 days.</li> </ul>	

**Table 12 (Continued)**  
**Trigger Action Response Plan – Cawley Road Overpass**

TFNSW – Cawley Road Overpass			
<i>Risk: Subsidence effect on bridge structure resulting in impact to structural integrity.</i>			
TRIGGER LEVEL	RESPONSE		
<b>Level 4 – Restoration</b> <b>Exceedance of nominated 1 in ~2000 probability or fault occurs</b>			
TFNSW – Cawley Road Overpass	Structural cracks greater than 1.0 mm width	<b><u>Implement Contingency Plan</u></b> <ul style="list-style-type: none"> <li>As per BFMP Section 9 and Appendix 9.</li> </ul>	
		<b><u>Metropolitan Coal (actions under the circumstances)</u></b> <ul style="list-style-type: none"> <li>Notify TFNSW, NSW Principal Subsidence Engineer, Subsidence Advisory NSW, and the Technical Committee of the Level 4 situation.</li> </ul>	<b><u>Timing / Frequency</u></b> <ul style="list-style-type: none"> <li>Within 2 hours.</li> </ul>
		<b><u>TFNSW (Works Supervisor)</u></b> <ul style="list-style-type: none"> <li>Notify TFNSW Traffic Commander via Transport Management Centre to immediately apply speed restriction.</li> <li>Inspect and assess condition of bridge at trigger point and general area, initiate any remedial action as required, and advise Technical Committee.</li> </ul>	<b><u>Timing / Frequency</u></b> <ul style="list-style-type: none"> <li>Immediately upon notification.</li> <li>Immediate callout and arrive within 2 hours.</li> </ul>
		<b><u>TFNSW (Traffic Commander) and NSW Police</u></b> <ul style="list-style-type: none"> <li>TFNSW Traffic Commander and NSW Police apply and enforce speed restriction, and determine if a detour is necessary.</li> </ul>	<b><u>Timing / Frequency</u></b> <ul style="list-style-type: none"> <li>Immediate callout and arrive within 2 hours.</li> </ul>
		<b><u>TFNSW (Technical Committee)</u></b> <ul style="list-style-type: none"> <li>Technical Committee to review monitoring data and consider whether to:                             <ul style="list-style-type: none"> <li>increase survey and/or inspection frequencies;</li> <li>take any additional management measures, including erecting temporary bridge props/supports or bringing forward the end-of-panel position; and/or</li> <li>suggest the need for mining to be temporarily halted (if unacceptable to TFNSW);</li> </ul> </li> </ul> and implement decisions following TFNSW and Metropolitan Coal concurrence.	<b><u>Timing / Frequency</u></b> <ul style="list-style-type: none"> <li>Within 3 days.</li> </ul>

**Table 13**  
**Trigger Action Response Plan – Pavement**

TFNSW – Pavements (Based on Incremental Movements due to Longwalls 306 and 307)		
<i>Risk: Subsidence effect on road pavement resulting in impact to structural integrity and serviceability.</i>		
TRIGGER LEVEL	RESPONSE	
<b>Level 1 - Normal</b>		
<b>Expected subsidence conditions</b>		
<ul style="list-style-type: none"> <li>Absolute Horizontal Movements less than 50 mm                             <ul style="list-style-type: none"> <li>– GNSS #3</li> <li>– GNSS #9</li> </ul> </li> <li>Relative Horizontal movement less than 15 mm between:                             <ul style="list-style-type: none"> <li>– GNSS #F208</li> <li>– GNSS #F210</li> </ul> </li> </ul>	<p><b><u>Normal Operations</u></b></p> <ul style="list-style-type: none"> <li>Road pavement is safe and serviceable.</li> <li>Negligible impact to road pavements.</li> <li>Continue monitoring activities as planned.</li> </ul>	
<b>Level 2 - Monitor</b>		
<b>Subsidence more than predicted (+15%), but road condition normal</b>		
<ul style="list-style-type: none"> <li>Absolute Horizontal Movements greater than level 1 and less than 75 mm                             <ul style="list-style-type: none"> <li>– GNSS #3</li> <li>– GNSS #9</li> </ul> </li> <li>Relative Horizontal movement greater than level 1 and less than 20 mm between:                             <ul style="list-style-type: none"> <li>– GNSS #F208</li> <li>– GNSS #F210</li> </ul> </li> </ul>	<p><b><u>Conditions: Continue operations but report on subsidence anomaly</u></b></p> <ul style="list-style-type: none"> <li>Road pavement is safe and serviceable.</li> <li>Impact on road pavement is within tolerable limits.</li> </ul>	
	<p><b><u>Metropolitan Coal (actions as required)</u></b></p> <ul style="list-style-type: none"> <li>Resurvey subsidence line and ground points to confirm results, and that the results are consistent with other subsidence lines.</li> <li>Inform and provide the report on subsidence results to TFNSW, NSW Principal Subsidence Engineer and Subsidence Advisory NSW.</li> </ul>	<p><b><u>Timing / Frequency</u></b></p> <ul style="list-style-type: none"> <li>Within 3 days.</li> <li>Within 7 days.</li> </ul>
	<p><b><u>TFNSW (Technical Committee)</u></b></p> <ul style="list-style-type: none"> <li>Technical Committee subsidence specialists to review monitoring data and assess results for trends, and forecast when the Level 3 trigger might be exceeded.</li> <li>Technical Committee to consider whether:                             <ul style="list-style-type: none"> <li>o to increase the frequency of survey and site inspections; and/or</li> <li>o any mitigation measures or additional management measures are required to avoid exceeding the Level 3 trigger.</li> </ul> </li> </ul>	<p><b><u>Timing / Frequency</u></b></p> <ul style="list-style-type: none"> <li>Within 7 days.</li> <li>Within 7 days.</li> </ul>

**Table 13 (Continued)**  
**Trigger Action Response Plan – Pavement**

TFNSW – Pavements (Based on Incremental Movements due to Longwalls 306 and 307)			
<i>Risk: Subsidence effect on road pavement resulting in impact to structural integrity and serviceability.</i>			
TRIGGER LEVEL	RESPONSE		
<b>Level 3 - Cautionary</b>			
<b>Anomalous road pavement defects or subsidence beyond +15% of predicted</b>			
<b>TFNSW – Pavements</b>	<ul style="list-style-type: none"> <li>Absolute Horizontal movement greater than Level 2 (75 mm) at either:                             <ul style="list-style-type: none"> <li>– GNSS #3</li> <li>– GNSS #9</li> </ul> </li> <li>Relative Horizontal movement greater than Level 2 (20 mm) between:                             <ul style="list-style-type: none"> <li>– GNSS #F208</li> <li>– GNSS #F210</li> </ul> </li> </ul>	<p><b><u>Conditions: Investigate &amp; Resolve</u></b></p> <ul style="list-style-type: none"> <li>Road pavement is safe and serviceable.</li> <li>Indication of impact to road pavements including observable subsidence ground deformations in/near pavement, pavement cracking, deterioration in ride quality, and defects in minor structures such as kerb &amp; gutter, pits, etc.</li> </ul>	
		<p><b><u>Metropolitan Coal (actions as required)</u></b></p> <ul style="list-style-type: none"> <li>Notify TFNSW, NSW Principal Subsidence Engineer, Subsidence Advisory NSW, and the Technical Committee that survey results show the trigger was exceeded and provide a report on the subsidence results.</li> <li>Provide a report to the NSW Principal Subsidence Engineer on how the Level 3 situation is being managed to keep the affected section of M1 safe and serviceable.</li> </ul>	<p><b><u>Timing / Frequency</u></b></p> <ul style="list-style-type: none"> <li>Within 24 hours.</li> <li>Within 2 weeks.</li> </ul>
	Horizontal movement per longwall	<p><b><u>TFNSW (Works Supervisor)</u></b></p> <ul style="list-style-type: none"> <li>Inspect and assess condition of pavement at trigger point and general area, determine if any remedial action required, and advise Technical Committee.</li> </ul>	<p><b><u>Timing / Frequency</u></b></p> <ul style="list-style-type: none"> <li>Within 4 hours of notification.</li> </ul>
	Observable subsidence ground deformations in/near pavement Pavement cracking Deterioration in ride quality Defects in minor structures such as kerbs and gutters, pits, etc	<p><b><u>TFNSW (Technical Committee)</u></b></p> <ul style="list-style-type: none"> <li>Technical Committee subsidence specialists to review monitoring data and assess results for trends, and forecast when the Level 4 trigger might be reached.</li> <li>Technical Committee to consider whether to:                             <ul style="list-style-type: none"> <li>○ increase survey and/or inspection frequencies;</li> <li>○ take any mitigation/additional management measures, including bringing forward the end-of-panel position, to avoid reaching the Level 4 trigger;</li> <li>○ employ a dedicated Inspector on site on full time basis; and/or</li> <li>○ suggest the need for a speed restriction to TFNSW, and implement decisions following TFNSW and Metropolitan Coal concurrence.</li> </ul> </li> </ul>	<p><b><u>Timing / Frequency</u></b></p> <ul style="list-style-type: none"> <li>Within 3 days.</li> <li>Within 5 days.</li> </ul>

**Table 13 (Continued)**  
**Trigger Action Response Plan – Pavement**

TFNSW – Pavements		
<i>Risk: Subsidence effect on road pavement resulting in impact to structural integrity and serviceability.</i>		
TRIGGER LEVEL	RESPONSE	
<b>Level 4 – Restoration</b>		
TFNSW – Pavements Impact to structural integrity and or serviceability of pavement occurs	<b><u>Implement Contingency Plan</u></b>	
	<ul style="list-style-type: none"> <li>As per BFMP Section 9 and Appendix 9.</li> </ul>	
	<b><u>Metropolitan Coal (actions under the circumstances)</u></b>	<b><u>Timing / Frequency</u></b>
	<ul style="list-style-type: none"> <li>Notify TFNSW, NSW Principal Subsidence Engineer, Subsidence Advisory NSW, and the Technical Committee of the Level 4 situation.</li> </ul>	<ul style="list-style-type: none"> <li>Within 2 hours.</li> </ul>
	<b><u>TFNSW (Works Supervisor)</u></b>	<b><u>Timing / Frequency</u></b>
	<ul style="list-style-type: none"> <li>Notify TFNSW Traffic Commander via Transport Management Centre to immediately apply speed restriction.</li> <li>Inspect and assess condition of pavement at trigger point and general area, initiate any remedial action as required, and advise Technical Committee.</li> </ul>	<ul style="list-style-type: none"> <li>Immediately upon notification.</li> <li>Immediate callout and arrive within 2 hours.</li> </ul>
<b><u>TFNSW (Traffic Commander) and NSW Police</u></b>	<b><u>Timing / Frequency</u></b>	
<ul style="list-style-type: none"> <li>TFNSW Traffic Commander and NSW Police apply and enforce speed restriction, and determine if a detour is necessary.</li> </ul>	<ul style="list-style-type: none"> <li>Immediate callout and arrive within 2 hours.</li> </ul>	
<b><u>TFNSW (Technical Committee)</u></b>	<b><u>Timing / Frequency</u></b>	
<ul style="list-style-type: none"> <li>Technical Committee to review monitoring data and consider whether to:                             <ul style="list-style-type: none"> <li>increase survey and/or inspection frequencies;</li> <li>mill, fill and/or cut slots;</li> <li>take any additional management measures, including bringing forward the end-of-panel position; and/or</li> <li>suggest the need for mining to be temporarily halted (if unacceptable to TFNSW);</li> </ul> </li> </ul> and implement decisions following TFNSW and Metropolitan Coal concurrence.	<ul style="list-style-type: none"> <li>Within 3 days.</li> </ul>	

**Table 14**  
**Trigger Action Response Plan – Cuttings**

TFNSW – Cuttings (Based on Incremental Movements due to Longwalls 306 and 307)		
<i>Risk: Subsidence effect on cuttings resulting in impact to stability.</i>		
TRIGGER LEVEL	RESPONSE	
<b>Level 1 - Normal</b>		
<b>Expected subsidence conditions</b>		
<ul style="list-style-type: none"> <li>Absolute Horizontal Movements less than 50 mm                             <ul style="list-style-type: none"> <li>– GNSS #3</li> <li>– GNSS #9</li> </ul> </li> <li>Relative Horizontal movement less than 15 mm between:                             <ul style="list-style-type: none"> <li>– GNSS #F208</li> <li>– GNSS #F210</li> </ul> </li> </ul>	<p><b><u>Normal Operations</u></b></p> <ul style="list-style-type: none"> <li>Cuttings are safe and serviceable.</li> <li>Negligible impact to cuttings.</li> <li>Continue monitoring activities as planned.</li> </ul>	
<b>Level 2 - Monitor</b>		
<b>Subsidence more than predicted (+15%), but cutting condition normal</b>		
<p><b>TFNSW – Cuttings</b></p> <ul style="list-style-type: none"> <li>Absolute Horizontal movements greater than level 1 and less than 75 mm                             <ul style="list-style-type: none"> <li>– GNSS #3</li> <li>– GNSS #9</li> </ul> </li> <li>Relative Horizontal movement greater than level 1 and less than 20 mm between:                             <ul style="list-style-type: none"> <li>– GNSS #F208</li> <li>– GNSS #F210</li> </ul> </li> </ul>	<p><b><u>Conditions: Continue operations but report on subsidence anomaly</u></b></p> <ul style="list-style-type: none"> <li>Cuttings are safe and serviceable.</li> <li>Impact on cuttings is within tolerable limits.</li> </ul>	
	<p><b><u>Metropolitan Coal (actions as required)</u></b></p> <ul style="list-style-type: none"> <li>Resurvey subsidence line and ground points to confirm results, and that the results are consistent with other subsidence lines.</li> <li>Inform and provide the report on subsidence results to TFNSW, NSW Principal Subsidence Engineer and Subsidence Advisory NSW.</li> </ul>	<p><b><u>Timing / Frequency</u></b></p> <ul style="list-style-type: none"> <li>Within 3 days.</li> <li>Within 7 days.</li> </ul>
	<p><b><u>TFNSW (Technical Committee)</u></b></p> <ul style="list-style-type: none"> <li>Technical Committee subsidence specialists to review monitoring data and assess results for trends, and forecast when the Level 3 trigger might be exceeded.</li> <li>Technical Committee to consider whether:                             <ul style="list-style-type: none"> <li>o to increase the frequency of survey and site inspections; and</li> <li>o any mitigation measures or additional management measures are required to avoid exceeding the Level 3 trigger.</li> </ul> </li> </ul>	<p><b><u>Timing / Frequency</u></b></p> <ul style="list-style-type: none"> <li>Within 7 days.</li> <li>Within 7 days.</li> </ul>
Metropolitan Coal – LW305 - 307 Built Features Management Plan – Transport for NSW		
Revision No. BFMP_TFNSW-R01-D		Page 60
Document ID: Built Features Management Plan - TFNSW		

**Table 14 (Continued)  
Trigger Action Response Plan – Cuttings**

TFNSW – Cuttings (Based on Incremental Movements due to Longwalls 306 and 307)		
<i>Risk: Subsidence effect on cuttings resulting in impact to stability.</i>		
TRIGGER LEVEL	RESPONSE	
<b>Level 3 - Cautionary</b>		
<b>Anomalous cutting impact/movement or subsidence beyond +15% of predicted</b>		
<b>TFNSW – Cuttings</b>  <ul style="list-style-type: none"> <li>• Absolute Horizontal movements greater than Level 2 (75 mm)                             <ul style="list-style-type: none"> <li>– GNSS #3</li> <li>– GNSS #9</li> </ul> </li> <li>• Relative Horizontal movement greater than Level 2 (20 mm)                             <ul style="list-style-type: none"> <li>– GNSS #F208</li> <li>– GNSS #F210</li> </ul> </li> </ul> Observable subsidence ground deformations in/near cutting Rock fall Cracking or visual deterioration at the rock face Visual displacement at joints	<b>Conditions: Investigate &amp; Resolve</b> <ul style="list-style-type: none"> <li>• Cuttings are safe and serviceable.</li> <li>• Indication of impact to cuttings including rock fall, cracking or visual deterioration at the rock face, or visual displacement at joints.</li> </ul>	
	<b>Metropolitan Coal (actions as required)</b> <ul style="list-style-type: none"> <li>• Notify TFNSW, NSW Principal Subsidence Engineer, Subsidence Advisory NSW, and the Technical Committee that survey results show the trigger was exceeded and provide a report on the subsidence results.</li> <li>• Provide a report to the NSW Principal Subsidence Engineer on how the Level 3 situation is being managed to keep the affected section of M1 safe and serviceable.</li> </ul>	<b>Timing / Frequency</b> <ul style="list-style-type: none"> <li>• Within 24 hours.</li> <li>• Within 2 weeks.</li> </ul>
	<b>TFNSW (Works Supervisor)</b> <ul style="list-style-type: none"> <li>• Inspect and assess condition of cutting at trigger point and general area, determine if any remedial action required, and advise Technical Committee.</li> </ul>	<b>Timing / Frequency</b> <ul style="list-style-type: none"> <li>• Within 4 hours of notification.</li> </ul>
	<b>TFNSW (Technical Committee)</b> <ul style="list-style-type: none"> <li>• Technical Committee subsidence specialists to review monitoring data and assess results for trends, and forecast when the Level 4 trigger might be reached.</li> <li>• Technical Committee to consider whether to:                             <ul style="list-style-type: none"> <li>○ increase survey and/or inspection frequencies;</li> <li>○ take any mitigation/additional management measures (e.g. rock bolting; scaling; shotcreting; installation of rockfall mesh; installation of barriers; and trimming of the cut face), including bringing forward the end-of-panel position, to avoid reaching the Level 4 trigger;</li> <li>○ employ a dedicated Inspector on site on full time basis; and/or</li> <li>○ suggest the need for a speed restriction to TFNSW, and implement decisions following TFNSW and Metropolitan Coal concurrence.</li> </ul> </li> </ul>	<b>Timing / Frequency</b> <ul style="list-style-type: none"> <li>• Within 3 days.</li> <li>• Within 5 days.</li> </ul>

**Table 14 (Continued)**  
**Trigger Action Response Plan – Cuttings**

TFNSW – Cuttings (Based on Incremental Movements due to Longwall 306 and 307)			
<i>Risk: Subsidence effect on cuttings resulting in impact to stability.</i>			
TRIGGER LEVEL	RESPONSE		
<b>Level 4 – Restoration</b>			
<b>TFNSW – Cuttings</b>	Impact occurs that creates instability in cutting that affects motorway operations	<p><b><u>Implement Contingency Plan</u></b></p> <ul style="list-style-type: none"> <li>As per BFMP Section 9 and Appendix 9.</li> </ul>	
		<p><b><u>Metropolitan Coal (actions under the circumstances)</u></b></p> <ul style="list-style-type: none"> <li>Notify TFNSW, NSW Principal Subsidence Engineer, Subsidence Advisory NSW, and the Technical Committee of the Level 4 situation.</li> </ul>	<p><b><u>Timing / Frequency</u></b></p> <ul style="list-style-type: none"> <li>Within 2 hours.</li> </ul>
		<p><b><u>TFNSW (Works Supervisor)</u></b></p> <ul style="list-style-type: none"> <li>Notify TFNSW Traffic Commander via Transport Management Centre to immediately apply speed restriction.</li> <li>Inspect and assess condition of cutting at trigger point and general area, initiate any remedial action as required, and advise Technical Committee.</li> </ul>	<p><b><u>Timing / Frequency</u></b></p> <ul style="list-style-type: none"> <li>Immediately upon notification.</li> <li>Immediate callout and arrive within 2 hours.</li> </ul>
		<p><b><u>TFNSW (Traffic Commander) and NSW Police</u></b></p> <ul style="list-style-type: none"> <li>TFNSW Traffic Commander and NSW Police apply and enforce speed restriction, and determine if a detour is necessary.</li> </ul>	<p><b><u>Timing / Frequency</u></b></p> <ul style="list-style-type: none"> <li>Immediate callout and arrive within 2 hours.</li> </ul>
		<p><b><u>TFNSW (Technical Committee)</u></b></p> <ul style="list-style-type: none"> <li>Technical Committee to review monitoring data and consider whether to:                             <ul style="list-style-type: none"> <li>increase survey and/or inspection frequencies;</li> <li>take any additional management measures (e.g. rock bolting; scaling; shotcreting; installation of rockfall mesh; installation of barriers; and trimming of the cut face), including bringing forward the end-of-panel position; and/or</li> <li>suggest the need for mining to be temporarily halted (if unacceptable to TFNSW);</li> </ul> </li> </ul> <p>and implement decisions following TFNSW and Metropolitan Coal concurrence.</p>	<p><b><u>Timing / Frequency</u></b></p> <ul style="list-style-type: none"> <li>Within 3 days.</li> </ul>

**Table 15**  
**Trigger Action Response Plan – Culverts**

TFNSW – Culverts (Based on Incremental Movements due to LW306 and LW307)		
<i>Risk: Subsidence effect on culvert structure resulting in impact to structural integrity.</i>		
TRIGGER LEVEL	RESPONSE	
<b>Level 1 - Normal</b>		
<b>Expected subsidence conditions</b>		
<ul style="list-style-type: none"> <li>Absolute Horizontal Movements less than 50 mm                             <ul style="list-style-type: none"> <li>– GNSS #3</li> <li>– GNSS #9</li> </ul> </li> <li>Relative Horizontal movement less than 15 mm between:                             <ul style="list-style-type: none"> <li>– GNSS #F208</li> <li>– GNSS #F210</li> </ul> </li> </ul>	<p><b><u>Normal Operations</u></b></p> <ul style="list-style-type: none"> <li>Culvert is safe and serviceable.</li> <li>Negligible impact to culvert structure.</li> <li>Continue monitoring activities as planned.</li> </ul>	
<b>Level 2 - Monitor</b>		
<b>Subsidence more than predicted (+15%), but culvert condition normal</b>		
<p><b>TFNSW – Culverts</b></p> <ul style="list-style-type: none"> <li>Absolute Horizontal movements greater than level 1 and less than 75 mm                             <ul style="list-style-type: none"> <li>– GNSS #3</li> <li>– GNSS #9</li> </ul> </li> <li>Relative Horizontal movement greater than level 1 and less than 20 mm between:                             <ul style="list-style-type: none"> <li>– GNSS #F208</li> <li>– GNSS #F210</li> </ul> </li> </ul>	<p><b><u>Conditions: Continue operations but report on subsidence anomaly</u></b></p> <ul style="list-style-type: none"> <li>Culvert is safe and serviceable.</li> <li>Impact on culvert structure is within tolerable limits.</li> </ul>	
	<p><b><u>Metropolitan Coal (actions as required)</u></b></p> <ul style="list-style-type: none"> <li>Resurvey subsidence line and ground points to confirm results, and that the results are consistent with other subsidence lines.</li> <li>Inform and provide the report on subsidence results to TFNSW, NSW Principal Subsidence Engineer and Subsidence Advisory NSW.</li> </ul>	<p><b><u>Timing / Frequency</u></b></p> <ul style="list-style-type: none"> <li>Within 3 days.</li> <li>Within 7 days.</li> </ul>
	<p><b><u>TFNSW</u></b></p> <ul style="list-style-type: none"> <li>Technical Committee subsidence specialists to review monitoring data and assess results for trends, and forecast when the Level 3 trigger might be exceeded.</li> <li>Technical Committee to consider whether:                             <ul style="list-style-type: none"> <li>o to increase the frequency of survey and site inspections; and</li> <li>o any mitigation measures or additional management measures are required to avoid exceeding the Level 3 trigger.</li> </ul> </li> </ul>	<p><b><u>Timing / Frequency</u></b></p> <ul style="list-style-type: none"> <li>Within 7 days.</li> <li>Within 7 days.</li> </ul>
Metropolitan Coal – LW305 - 307 Built Features Management Plan – Transport for NSW		
Revision No. BFMP_TFNSW-R01-D		Page 63
Document ID: Built Features Management Plan - TFNSW		

**Table 15 (Continued)  
Trigger Action Response Plan – Culverts**

TFNSW – Culverts (Based on Incremental Movements due to Longwalls 306 and 307)		
<i>Risk: Subsidence effect on culvert structure resulting in impact to structural integrity.</i>		
TRIGGER LEVEL	RESPONSE	
<b>Level 3 - Cautionary</b>		
<b>Anomalous culvert impact/movement or subsidence beyond +15% of predicted</b>		
<b>TFNSW – Culverts</b>  <ul style="list-style-type: none"> <li>Absolute Horizontal movements greater than Level 2 (75 mm)                             <ul style="list-style-type: none"> <li>– GNSS #3</li> <li>– GNSS #9</li> </ul> </li> <li>Relative Horizontal movement greater than Level 2 (20 mm)                             <ul style="list-style-type: none"> <li>– GNSS #F208</li> <li>– GNSS #F210</li> </ul> </li> </ul> Observable subsidence ground deformations in/near culverts Cracking in culverts Visual displacement at joints Ponding	<ul style="list-style-type: none"> <li><b>Conditions: Investigate &amp; Resolve</b> <ul style="list-style-type: none"> <li>Culvert is safe and serviceable.</li> <li>Indication of impact to culvert structure including cracking in culverts, visual displacement at joints or ponding.</li> </ul> </li> </ul>	
	<ul style="list-style-type: none"> <li><b>Metropolitan Coal (actions as required)</b> <ul style="list-style-type: none"> <li>Notify TFNSW, NSW Principal Subsidence Engineer, Subsidence Advisory NSW, and the Technical Committee that survey results show the trigger was exceeded and provide a report on the subsidence results.</li> <li>Provide a report to the NSW Principal Subsidence Engineer on how the Level 3 situation is being managed to keep the affected culvert section safe and serviceable.</li> </ul> </li> </ul>	<b>Timing / Frequency</b> <ul style="list-style-type: none"> <li>Within 24 hours.</li> <li>Within 2 weeks.</li> </ul>
	<ul style="list-style-type: none"> <li><b>TFNSW (Works Supervisor)</b> <ul style="list-style-type: none"> <li>Inspect and assess condition of culvert at trigger point and general area, determine if any remedial action required, and advise Technical Committee.</li> </ul> </li> </ul>	<b>Timing / Frequency</b> <ul style="list-style-type: none"> <li>Within 4 hours of notification.</li> </ul>
	<ul style="list-style-type: none"> <li><b>TFNSW (Technical Committee)</b> <ul style="list-style-type: none"> <li>Technical Committee subsidence specialists to review monitoring data and assess results for trends, and forecast when the Level 4 trigger might be reached.</li> <li>Technical Committee to consider whether to:                                     <ul style="list-style-type: none"> <li>increase survey and/or inspection frequencies;</li> <li>take any mitigation/additional management measures (e.g. point repairs; lining; grouting; or culvert replacement), including bringing forward the end-of-panel position, to avoid reaching the Level 4 trigger;</li> <li>employ a dedicated Inspector on site on full time basis; and/or</li> <li>suggest the need for a speed restriction to TFNSW, and implement decisions following TFNSW and Metropolitan Coal concurrence.</li> </ul> </li> </ul> </li> </ul>	<b>Timing / Frequency</b> <ul style="list-style-type: none"> <li>Within 3 days.</li> <li>Within 5 days.</li> </ul>

**Table 15 (Continued)  
Trigger Action Response Plan – Culverts**

TFNSW – Culverts (Based on Incremental Movements due to LW306 and LW307)			
<i>Risk: Subsidence effect on culvert structure resulting in impact to structural integrity.</i>			
TRIGGER LEVEL	RESPONSE		
<b>Level 4 – Restoration</b>			
<b>TFNSW – Culverts</b>	Impact occurs to culvert resulting in loss of culvert structural integrity that impacts motorway operations	<p><b><u>Implement Contingency Plan</u></b></p> <ul style="list-style-type: none"> <li>As per BFMP Section 9 and Appendix 9.</li> </ul>	
		<p><b><u>Metropolitan Coal (actions under the circumstances)</u></b></p> <ul style="list-style-type: none"> <li>Notify TFNSW, NSW Principal Subsidence Engineer, Subsidence Advisory NSW, and the Technical Committee of the Level 4 situation.</li> </ul>	<p><b><u>Timing / Frequency</u></b></p> <ul style="list-style-type: none"> <li>Within 2 hours.</li> </ul>
		<p><b><u>TFNSW (Works Supervisor)</u></b></p> <ul style="list-style-type: none"> <li>Notify TFNSW Traffic Commander via Transport Management Centre to immediately apply speed restriction.</li> <li>Inspect and assess condition of culvert at trigger point and general area, initiate any remedial action as required, and advise Technical Committee.</li> </ul>	<p><b><u>Timing / Frequency</u></b></p> <ul style="list-style-type: none"> <li>Immediately upon notification.</li> <li>Immediate callout and arrive within 2 hours.</li> </ul>
		<p><b><u>TFNSW (Traffic Commander) and NSW Police</u></b></p> <ul style="list-style-type: none"> <li>TFNSW Traffic Commander and NSW Police apply and enforce speed restriction, and determine if a detour is necessary.</li> </ul>	<p><b><u>Timing / Frequency</u></b></p> <ul style="list-style-type: none"> <li>Immediate callout and arrive within 2 hours.</li> </ul>
		<p><b><u>TFNSW (Technical Committee)</u></b></p> <ul style="list-style-type: none"> <li>Technical Committee to review monitoring data and consider whether to:                             <ul style="list-style-type: none"> <li>increase survey and/or inspection frequencies;</li> <li>take any additional management measures (e.g. point repairs; lining; grouting; or culvert replacement), including bringing forward the end-of-panel position; and/or</li> <li>suggest the need for mining to be temporarily halted (if unacceptable to TFNSW);</li> </ul> </li> </ul> <p>and implement decisions following TFNSW and Metropolitan Coal concurrence.</p>	<p><b><u>Timing / Frequency</u></b></p> <ul style="list-style-type: none"> <li>Within 3 days.</li> </ul>

## 11 FUTURE EXTRACTION PLANS

In accordance with Condition 7, Schedule 3 of the Project Approval, Metropolitan Coal will collect baseline data for the next Extraction Plan (i.e. Longwall 308 on). The collection of baseline data will be consistent with the baseline data collected for Longwalls 301-307.

However, for the M1 Princes Motorway and associated bridges, the baseline (and post-mining) data collected for Longwalls 301-307 will be used as baseline for Longwalls 308 onward as longwall mining progressively moves further away from the TFNSW assets.

In addition to the baseline data collection, consideration of the environmental performance and management measures in accordance with the review(s) conducted as part of this BFMP-TFNSW will inform the appropriate type and frequency of monitoring of the assets relevant to the next Extraction Plan.

## 12 ANNUAL REVIEW AND IMPROVEMENT OF ENVIRONMENTAL PERFORMANCE

In accordance with Condition 3, Schedule 7 of the Project Approval, Metropolitan Coal will conduct an Annual Review of the environmental performance of the Project by the end of March each year.

The Annual Review will:

- describe the works carried out in the past year, and the works proposed to be carried out over the next year;
- include a comprehensive review of the monitoring results and complaints records of the Project over the past year, including a comparison of these results against the:
  - relevant statutory requirements, limits or performance measures/criteria;
  - monitoring results of previous years; and
  - relevant predictions in the EA, Preferred Project Report and Extraction Plan.
- identify any non-compliance over the last year, and describe what actions were (or are being) taken to ensure compliance;
- identify any trends in the monitoring data over the life of the Project;
- identify any discrepancies between the predicted and actual impacts of the Project, and analyse the potential cause of any significant discrepancies; and
- describe what measures will be implemented over the next year to improve the environmental performance of the Project.

As described in Section 2, this BFMP-TFNSW will be reviewed within three months of the submission of an Annual Review, and revised where appropriate.

Metropolitan Coal – LW305-307 Built Features Management Plan – Roads and Maritime Services		
Revision No. BFMP_TFNSW-R01-D	ME-TSE-MNP-0088	Page 66
Document ID: Built Features Management Plan - TFNSW		

### 13 INCIDENTS

An incident is defined as a set of circumstances that causes or threatens to cause material harm to the environment, and/or breaches or exceeds the limits or performance measures/criteria in the Project Approval.

The reporting of incidents will be conducted in accordance with Condition 6, Schedule 7 of the Project Approval. Metropolitan Coal will notify the Secretary of DPIE and any other relevant agencies of any incident associated with the Project as soon as practicable after Metropolitan Coal becomes aware of the incident. Within seven days of the date of the incident, Metropolitan Coal will provide the Secretary) of DPIE and any relevant agencies with a detailed report on the incident.

The TFNSW will be notified within 24 hours of any access limitations or restrictions.

### 14 COMPLAINTS

A protocol for the managing and reporting of complaints has been developed as a component of Metropolitan Coal's Environmental Management Strategy and is described below.

The Environment & Community Superintendent is responsible for maintaining a system for recording complaints.

Metropolitan Coal will maintain public signage advertising the telephone number on which environmental complaints can be made. The Environment & Community Superintendent is responsible for ensuring that the currency and effectiveness of the service is maintained. Notifications of complaints received are to be provided as quickly as practicable to the Environment & Community Superintendent.

Complaints and enquiries do not have to be received via the telephone line and may be received in any other form. Any complaint or enquiry relating to environmental management or performance is to be relayed to the Environment & Community Superintendent as soon as practicable. All employees are responsible for ensuring the prompt relaying of complaints. All complaints will be recorded in a complaints register.

For each complaint, the following information will be recorded in the complaints register:

- date and time of complaint;
- method by which the complaint was made;
- personal details of the complainant which were provided by the complainant or, if no such details were provided, a note to that effect;
- nature of the complaint;
- the action(s) taken by Metropolitan Coal in relation to the complaint, including any follow-up contact with the complainant; and
- if no action was taken by Metropolitan Coal, the reason why no action was taken.

The Environment & Community Superintendent is responsible for ensuring that all complaints are appropriately investigated, actioned and that information is fed back to the complainant, unless requested to the contrary.

Metropolitan Coal – LW305-307 Built Features Management Plan – Roads and Maritime Services		
Revision No. BFMP_TFNSW-R01-D	ME-TSE-MNP-0088	Page 67
Document ID: Built Features Management Plan - TFNSW		

In accordance with Condition 10, Schedule 7 of the Project Approval, the complaints register will be made publicly available on the website and updated on a monthly basis. A summary of complaints received and actions taken will be presented to the Community Consultative Committee as part of the operational performance review.

## 15 NON-COMPLIANCE WITH STATUTORY REQUIREMENTS

A protocol for the managing and reporting of non-compliances with statutory requirements has been developed as a component of Metropolitan Coal's Environmental Management Strategy and is described below.

Compliance with all approvals, plans and procedures will be the responsibility of all personnel (staff and contractors) employed on or in association with Metropolitan Coal, and will be developed through promotion of Metropolitan Coal ownership under the direction of the General Manager.

The Technical Services Manager and/or Environment & Community Superintendent will undertake regular inspections, internal audits and initiate directions identifying any remediation/rectification work required, and areas of actual or potential non-compliance.

As described in Section 13, Metropolitan Coal will notify the Secretary of the DPIE and any other relevant agencies of any incident associated with Metropolitan Coal as soon as practicable after Metropolitan Coal becomes aware of the incident. Within seven days of the date of the incident, Metropolitan Coal will provide the Secretary of the DPIE and any relevant agencies with a detailed report on the incident.

A review of Metropolitan Coal's compliance with all conditions of the Project Approval, mining leases and all other approvals and licenses will be undertaken prior to (and included within) each Annual Review. The Annual Review will be made publicly available on the Peabody website.

Additionally, in accordance with Condition 8, Schedule 7 of the Project Approval, an independent environmental audit was undertaken by the end of December 2011, and is undertaken a minimum of once every three years thereafter. A copy of the audit report will be submitted to the Secretary of the DPIE and made publicly available on the Peabody website. The independent audit will be undertaken by an appropriately qualified, experienced and independent team of experts whose appointment has been endorsed by the Secretary of the DPIE.

Metropolitan Coal – LW305-307 Built Features Management Plan – Roads and Maritime Services		
Revision No. BFMP_TFNSW-R01-D	ME-TSE-MNP-0088	Page 68
Document ID: Built Features Management Plan - TFNSW		

## 16 REFERENCES

- AECOM (2019) Memorandum: *Metropolitan Coal – LW304 – Bridge 2 Trigger Review, Ref No. 60546746, 20 August 2019.*
- Arup (2016) Metropolitan Colliery Longwall Mining – LW301-303 Risk Assessment as Applied to RMS Assets.
- Arup (2019) Metropolitan Colliery Longwall Mining – LW304-306 Risk Assessment as Applied to RMS Assets.
- Arup (2019) Metropolitan Colliery Longwall Mining – LW305-307 Risk Assessment as Applied to RMS Assets.
- Cardno (2008) *Bridges Near Proposed Longwalls 18 to 44 at Metropolitan Colliery - Preliminary Investigation of Potential Effects of Ground Movement due to Mining on Three Bridges.* Cardno Report 607126-R-1, June 2008.
- Cardno (2009a) *Bridges Near Proposed Longwalls 20 to 22 at Metropolitan Colliery - Additional Investigation of Potential Effects of Ground Movement due to Mining on Two Bridges.* Cardno Report 607126-R-2, March 2009.
- Cardno (2009b) *Bridges Near Proposed Longwalls 20 to 22 at Metropolitan Colliery - Investigation of Potential Effects on Bridges of Ground Movement Due to Mining.* Cardno Report 607126 Report No. 3, 20 July 2009.
- Cardno (2009c) *Bridges Near Proposed Longwalls 20 to 22 at Metropolitan Colliery - Monitoring of Effects on Bridges of Ground Movements Due to Mining.* Cardno Report 607126 Report No. 4, 8 December 2009.
- Cardno (2013) *Bridges Near Proposed Longwalls 23-27 at Metropolitan Colliery Investigation of Potential Effects of Ground Movement due to Mining,* Letter 23 May 2013.
- Cardno (2015a) *Investigation of Potential Effects on Underpass 2 over Princes Highway of Ground Movement Due to Mining.* May 2015.
- Cardno (2015b) *Supplementary Report on Investigation of Potential Effects on Underpass 2 over Princes Highway of Ground Movement Due to Mining.* July 2015.
- Cardno (2016) *Investigation of Potential Effects on Cawley Road Overbridge of Ground Movement due to Mining.* October 2016.
- Department of Planning & Environment and Division of Resources and Energy (2014) *Guidelines for the Preparation of Extraction Plans.* Draft.
- Helensburgh Coal Pty Ltd (2008) *Metropolitan Coal Project Environmental Assessment.*
- Helensburgh Coal Pty Ltd (2009) *Metropolitan Coal Project Preferred Project Report.*
- Mine Subsidence Engineering Consultants (2008) *Metropolitan Colliery Longwalls 20-44 Subsidence Assessment Report (MSEC Report MSEC285 Revision C, August 2008), Appendix A in Helensburgh Coal Pty Ltd (2008) Metropolitan Coal Project Environmental Assessment.*

Metropolitan Coal – LW305-307 Built Features Management Plan – Roads and Maritime Services		
Revision No. BFMP_TFNSW-R01-D	ME-TSE-MNP-0088	Page 69
Document ID: Built Features Management Plan - TFNSW		

Mine Subsidence Engineering Consultants (2016) *Metropolitan Colliery – Proposed Longwalls 301 to 303 – Subsidence Predictions and Impact Assessments for the Roads and Maritime Services Infrastructure*, 6 September 2016.

Mine Subsidence Engineering Consultants (2019) *Metropolitan Colliery – Proposed Longwall 304 – Subsidence Predictions and Impact Assessments for the Roads and Maritime Services Infrastructure*.

Mine Subsidence Engineering Consultants (2019) *Metropolitan Colliery – Proposed Longwalls 305 – 307 Subsidence Predictions and Impact Assessments for the Roads and Maritime Services Infrastructure*.

Roads and Maritime Services (2014) *Guide to Slope Risk Analysis Version 4*.

Metropolitan Coal – LW305-307 Built Features Management Plan – Roads and Maritime Services		
Revision No. BFMP_TFNSW-R01-D	ME-TSE-MNP-0088	Page 70
Document ID: Built Features Management Plan - TFNSW		

APPENDIX 1

MSEC (2016) METROPOLITAN COLLIERY – PROPOSED LONGWALLS 301 TO 303 -  
SUBSIDENCE PREDICTIONS AND IMPACT ASSESSMENTS FOR THE ROADS AND  
MARITIME SERVICES INFRASTRUCTURE,  
DATED 6 SEPTEMBER 2016

Metropolitan Coal – LW305-307 Built Features Management Plan – Roads and Maritime Services		
Revision No. BFMP_TFNSW-R01-D	ME-TSE-MNP-0088	
Document ID: Built Features Management Plan - TFNSW		

6<sup>th</sup> September 2016

Jon Degotardi  
Peabody Energy Australia  
Metropolitan Colliery  
PO Box 402  
Helensburgh NSW 2508

Ref: MSEC844-08

Dear Jon,

**RE: Metropolitan Colliery – Proposed Longwalls 301 to 303 - Subsidence Predictions and Impact Assessments for the Roads and Maritime Services Infrastructure**

This letter report summarises the predicted subsidence movements and the assessed subsidence impacts for the Roads and Maritime Services (RMS) infrastructure resulting from the extraction of the proposed Longwalls 301 to 303 at Metropolitan Colliery.

The locations of the RMS infrastructure and the proposed longwalls are shown in the attached Drawing No. MSEC844-08. The M1 Princes Motorway is located to the east of Longwalls 301 to 303. The distance of the M1 Princes Motorway from Longwalls 301 to 303 varies from 210 metres near the finishing (southern) end of Longwall 301 to 335 metres near the commencing (northern) end of Longwall 301.

A series of cuttings and embankments up to a maximum height of approximately 20 metres are shown in the attached Drawing No. MSEC844-08. A summary of the rock cuttings is provided in Table 1.

**Table 1 Summary of RMS Rock Cuttings**

RMS Slope Number	RMS Assessed Risk Level (ARL)	Length (m)	Maximum Slope Height (m)	Average Slope Angle (degrees)
13563	2	202	17	65
13562	2	531	18	70
13561	2	599	13	62
13560	2	231	8	70
10425	2	188	9	66
10426	2	503	15	55
10427	2	452	14	55
10428	2	192	9	65

A bridge is located at the crossing of the M1 Princes Motorway with the Old Princes Highway (Bridge 2), and is located approximately 330 metres from Longwall 301. The next nearest bridge is Cawley Road Overpass, which is located approximately 1.43 kilometres to the north east of Longwall 303.

A series of culverts cross the M1 Princes Motorway, as shown on Drawing No. MSEC844-08. The culverts comprise pipes of varying diameters from 375 mm to 1800 mm. The pipe materials comprise asbestos cement (pipes up to

600 mm diameter) and steel reinforced concrete (pipes up to 1800 mm diameter). In addition to the culverts, there are also a number of other drainage structures, such as kerbs, gutters, pits and drainage pipes. The largest culvert comprises two 1800mm pipes located to the north east of the longwalls at Cawley's Creek.

The predictions and impact assessments for the RMS infrastructure are provided in the following sections.

### Conventional Subsidence Parameters for the RMS Infrastructure

A summary of the maximum predicted values of total subsidence, tilt and curvature for the M1 Princes Motorway, resulting from the extraction of Longwalls 301 to 303, is provided in Table 2. The values are the maxima anywhere along the section of the motorway located within the Study Area.

**Table 2 Predicted Total Subsidence, Tilt and Curvature for the M1 Princes Motorway Resulting from the Extraction of Longwalls 301 to 303**

Longwall	Maximum Predicted Total Conventional Subsidence (mm)	Maximum Predicted Total Conventional Tilt (mm/m)	Maximum Predicted Total Conventional Hogging Curvature (km <sup>-1</sup> )	Maximum Predicted Total Conventional Sagging Curvature (km <sup>-1</sup> )
After LW301	< 20	< 0.5	< 0.01	< 0.01
After LW302	50	< 0.5	< 0.01	< 0.01
After LW303	50	< 0.5	< 0.01	< 0.01

The maximum predicted conventional tilt and curvature are negligible and less than typical limits of survey accuracy (i.e. 0.5 mm/m for tilt and 0.01 km<sup>-1</sup> for curvature).

Princes Motorway will potentially experience low level far-field horizontal movement. The far-field horizontal movements are expected to be similar to those observed for previous longwall mining in the Southern Coalfield.

The observed incremental far-field horizontal movements, resulting from the extraction of longwalls in the Southern Coalfield, are provided in Figure 1. The data are based on survey marks located outside of the mining area (i.e. above solid coal).

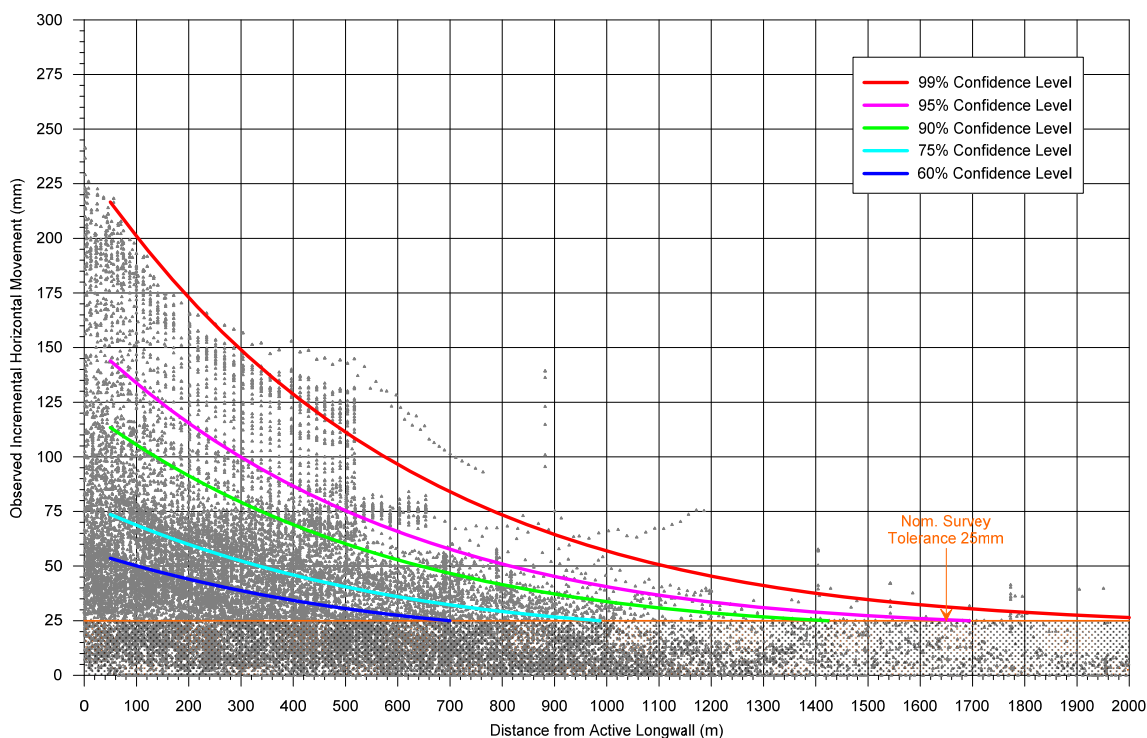

**Figure 1 Observed Incremental Far-field Horizontal Movements from the Southern Coalfield (Solid Coal)**

The absolute horizontal movements measured at distances greater than 210 metres from mining are in the order of 115 mm based on the 95 % confidence level. These low level movements comprise a large proportion of survey tolerance. Far-field horizontal movements tend to be bodily movements orientated towards the mining area. The strains associated with these low level horizontal movement are not expected to be measurable.

### **Predicted Strains**

The prediction of strain is more difficult than the predictions of subsidence and tilt. The reason for this is that strain is affected by many factors, including ground curvature and horizontal movement, as well as local variations in the near surface geology, the locations of pre-existing natural joints at bedrock and the depth of bedrock. Survey tolerance can also represent a substantial portion of the measured strain, in cases where the strains are of a low order of magnitude. The profiles of observed strain, therefore, can be irregular even when the profiles of observed subsidence, tilt and curvature are relatively smooth.

In previous MSEC subsidence reports, predictions of conventional strain were provided based on the best estimate of the average relationship between curvature and strain. Similar relationships have been proposed by other authors. The reliability of the strain predictions was highlighted in these reports, where it was stated that measured strains can vary considerably from the predicted conventional values.

Adopting a linear relationship between curvature and strain provides a reasonable prediction for the conventional tensile and compressive strains. In the Southern Coalfield, it has been found that a factor of 15 provides a reasonable relationship between the predicted maximum curvatures and the predicted maximum conventional strains. The locations that are predicted to experience hogging or convex curvature are expected to be net tensile strain zones and locations that are predicted to experience sagging or concave curvature are expected to be net compressive strain zones.

At a point however, there can be considerable variation from the linear relationship, resulting from non-conventional movements or from the normal scatters which are observed in strain profiles. When expressed as a percentage, observed strains can be many times greater than the predicted conventional strain for low magnitudes of curvature. We have therefore provided a statistical approach to account for the variability, instead of just providing a single predicted conventional strain.

The range of predicted strains for the RMS infrastructure has been determined using the monitoring data from Metropolitan Colliery and other nearby collieries. The data used in the analysis of observed strains included those resulting from both conventional and non-conventional anomalous movements, but did not include those resulting from valley related movements. The strains resulting from damaged or disturbed survey marks have also been excluded.

The M1 Princes Motorway is located at distances of 200 metres or greater from the longwalls. The database of measured strains has therefore been analysed to extract the maximum tensile and compressive strains that have been measured at any time during the extraction of the previous longwalls in the Southern Coalfield, for survey bays that were located outside and within 100 metres to 250 metres of the nearest longwall goaf edge, which has been referred to as "*above solid coal*".

A histogram of the maximum observed tensile and compressive strains measured in survey bays located above solid coal, for monitoring lines in the Southern Coalfield, is provided in Figure 2. The probability distribution functions, based on a fitted *Generalised Pareto Distribution (GPD)*, have also been shown in this figure.

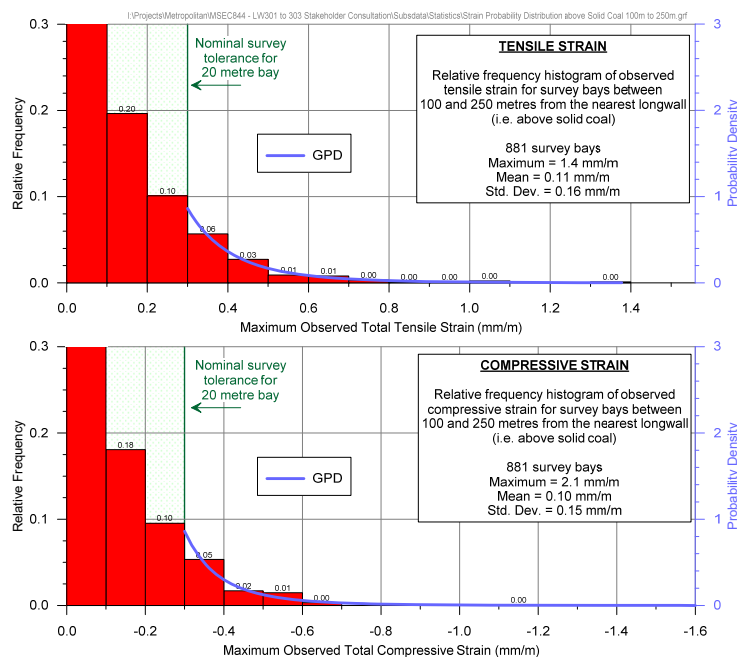

**Figure 2 Distributions of the Measured Maximum Tensile and Compressive Strains during the Extraction of Previous Longwalls in the Southern Coalfield Above Solid Coal (100 to 250 metres)**

Confidence intervals have been determined from the empirical strain data using the fitted GPDs. In the cases where survey bays were measured multiple times during a longwall extraction, the maximum tensile strain and the maximum compressive strain were used in the analysis (i.e. single tensile strain and single compressive strain measurement per survey bay).

A summary of the probabilities of exceedance for tensile and compressive strains for survey bays located above solid coal, based on the fitted GPDs, is provided in Table 3.

**Table 3 Probabilities of Exceedance for Strain for Survey Bays Located above Solid Coal**

Strain (mm/m)		Probability of Exceedance
Compression	-2.0	1 in 9,840
	-1.5	1 in 3000
	-1.0	1 in 635
	-0.5	1 in 55
	-0.3	1 in 10
Tension	+0.3	1 in 9
	+0.5	1 in 36
	+1.0	1 in 410
	+1.5	1 in 2,200
	+2.0	1 in 8,000

The 95 % confidence intervals for the maximum total strains that the individual survey bays above solid coal (100 to 250 metres) experienced at any time during mining are 0.4 mm/m tensile and compressive. The 99 % confidence intervals for the maximum total strains that the individual survey bays above solid coal experienced at any time during mining are 0.7 mm/m tensile and 0.6 mm/m compressive.

## Potential for Non-Conventional Movements

Non-conventional movements can develop due to the presence of geological structures or valley related effects. In some cases, non-conventional movements can develop with no known cause and these are often referred to as 'anomalous' movements.

The locations of the known geological structures and the streams are shown in Drawing No. MSEC844-08.

There are no identified geological structures above the longwalls. The M1 Princes Motorway crosses the Metropolitan Fault approximately 500 metres to the north east of Longwall 301 and several faults to the south east of Longwalls 301 and 302 intersecting the M1 Princes Motorway at approximately 340 metres. The absolute horizontal movements measured at distances of 500 metres and 340 metres from mining are in the order of 75 mm and 95 mm respectively based on the 95 % confidence level. It is noted that these faults are identified at seam level and surface expression of faults may occur at different locations, or faults may not have continuity to the ground surface.

A drainage line crosses the M1 Princes Motorway approximately 210 metres east of the finishing end of Longwall 301, as shown on Drawing No. MSEC844-08. Predicted valley closure across the culvert at the location of the M1 Princes Motorway is less than 20 mm.

A second drainage line is located to the north of the longwalls at Cawley's Creek. Due to the shortened commencing end of the longwalls, the culvert is located approximately 1060 metres from the nearest longwall (Longwall 301). At this distance, the culvert is not predicted to experience valley related movements due to the extraction of the Longwalls 301 to 303.

Valley closure is not expected to occur in the cuttings along the M1 Princes Motorway, however, minor closure movements could be observed due to potential horizontal movements.

## Impact Assessments for the M1 Princes Motorway

The predicted conventional vertical subsidence for the M1 Prince Motorway resulting from the extraction of Longwalls 301 to 303 are very small and the predicted tilts and curvatures are less than the expected limits of survey tolerance. Adverse impacts to the M1 Princes Motorway, including the road pavement, slopes, culverts, barriers and furniture, resulting from conventional subsidence movements is considered unlikely.

The M1 Princes Motorway will potentially experience far-field horizontal movements resulting from the extraction of the Longwalls 301 to 303 of up to 115 mm, based on the 95% confidence level.

There are no major geological features to the east of the longwalls near the M1 Princes Motorway. The mapped geological features are shown on Drawing No. MSEC846-08. The Metropolitan Fault intersects the M1 Princes Motorway at approximately 500 metres to the north east of Longwall 301. There are mapped faults to the south east of Longwalls 301 and 302, intersecting the M1 Princes Motorway at approximately 340 metres from the longwalls. A dyke with a surface exposure is also present to the east of Longwall 301 at approximately 380 metres from Longwall 301. There is the potential for far-field horizontal movements to result in the minor differential movement near the faults and potential shearing and/or stepping in the road pavement. The faults have been mapped at seam level and surface expressions have not been identified. The mapped dyke has been identified in the motorway cuttings. There is also the potential for far-field horizontal movements to result in differential movement at the interface of cut and fill areas along the motorway corridor.

The M1 Princes Motorway crosses a valley and an associated drainage culvert to the east of the Longwall 301 finishing end. The predicted valley closure due to Longwalls 301 to 303 is less than 20 mm. A second valley and culvert are located at Cawley's Creek, approximately 930 metres from Longwall 303. Adverse impacts to the culverts resulting from conventional subsidence and valley related movements is considered unlikely.

It is recommended that monitoring and management strategies are developed, in consultation with RMS, to manage the potential impacts on the M1 Princes Motorway. It is expected that the motorway can be maintained in safe and serviceable conditions with the implementation of the appropriate monitoring and management strategies.

## Impact Assessments for the Bridges

An assessment of Bridge 2 (RMS reference BN616-southbound and BN617-northbound) has been undertaken by the RMS technical committee, which was formed prior to the commencement of the extraction of Longwall 20 to assess and monitor potential impacts to RMS assets due to the extraction of longwalls at Metropolitan Colliery. A letter report MSEC696-02 dated 30<sup>th</sup> June 2014 was prepared based on a preliminary layout of Longwalls 301 to 317. The distance of the bridge from the longwalls is unchanged at 330 metres hence the impact assessments are the same as previously reported. A summary of the subsidence predictions and impact assessments for Bridge 2 is provided below.

- At a distance of approximately 330 metres, the predicted subsidence parameters are less than survey tolerance, which is typically 20mm for subsidence, 0.5mm/m for tilt and 0.01km<sup>-1</sup> for curvature. The predicted conventional subsidence parameters indicate that with high accuracy survey, minor subsidence, tilt and hogging curvature may be observed, but sagging curvature is unlikely to be observed.
- The absolute horizontal movements measured at distances greater than 330 metres are in the order of 95 mm based on the 95% confidence level. An absolute horizontal movement of 105 mm based on the 95% confidence level was provided in the MSEC696-02 report. The updated data set as presented in Figure 1 results in a slightly lower value of observed horizontal movement, however the difference of 10 mm does not change the impact assessments for the bridge.
- It is difficult to predict differential horizontal movements since the potential values of relative movement are typically very small and much of the scatter in the observed data is the result of survey accuracy. Also, a spacing between pegs of 20 metres is commonly used along monitoring lines, and this distance is larger than the typical column and blade wall spacing for Bridge 2.
- Differential horizontal movement was assessed by analysing the far-field horizontal movement data discussed above. The data set was analysed to determine incremental relative opening and closing and incremental mid ordinate deviation.
- The incremental relative opening and closing and mid ordinate deviation for various probabilities at a distance of approximately 330 metres from an active longwall are summarised in Table 4 and Table 5.

**Table 4 Incremental Relative Opening, Closing and Mid-Ordinate Deviation at Approximately 330 metres Distance from Active Longwall**

	1 in 20 probability (95% confidence level)	1 in 100 probability (99% confidence level)	1 in 2000 probability (99.95% confidence level)
Opening	8 mm	14 mm	44 mm
Closing	6 mm	13 mm	44 mm
Mid-Ordinate Deviation	9 mm	15 mm	32 mm

**Table 5 Incremental Relative Opening, Closing and Mid-Ordinate Deviation due to First Panel Extraction Only**

	1 in 20 probability (95% confidence level)	1 in 100 probability (99% confidence level)	1 in 2000 probability (99.95% confidence level)
Opening	5 mm	10 mm	25 mm
Closing	4 mm	9 mm	32 mm
Mid Ordinate Deviation	5 mm	8 mm	14 mm

- The differential movements presented in Table 4 and Table 5 should be applied to the bridge elements in both the longitudinal and transverse direction of the bridge. The application of the differential movements to short bridge element spacing (e.g. columns approximately 5m apart), was discussed by the technical committee and it was agreed that the movements should be applied directly to shorter element spacing.
- The differential longitudinal movement, opening (+ve) and closing (-ve) should be applied to the longitudinal and transverse direction as an opening and closing movement, between piers, and between columns. The mid-ordinate deviation should be applied to an out of plane movement of one pier relative to adjacent piers, which are spaced at 13.5 metres at abutments and 18.3 metres in the centre, as well as between columns which are approximately 5 metres apart.
- Faults have been identified at seam level to the west and to the east of Bridge 2. The nearest faults, Main West and Powel are approximately 235 metres horizontal distance from Bridge 2. There are no mapped surface expressions of the faults. The projected alignments of these faults do not intersect the location of Bridge 2. There is a low likelihood of the identified structures directly impacting Bridge 2, however other potential unidentified structures may be present at or near the bridge location.

A decision was made by the RMS technical committee to monitor potential movements of Bridge 2 using a high accuracy fibre optic monitoring system, along with conventional surveying methods. The monitoring system is being established to record baseline readings during the extraction of Longwalls 26 and 27, prior to the commencement of Longwall 301.

Cawley Road Overpass is located at 1.43 kilometres from Longwall 301 at its nearest point. At this distance, observed far-field movements as shown in Figure 1 are close to nominal survey tolerance and observed differential movement data is predominantly within survey tolerance. Differential horizontal movement was assessed by analysing the far-field horizontal movement data. The data set was analysed to determine incremental relative opening and closing and incremental mid ordinate deviation at a distance of approximately 1.43 kilometres from an active longwall.

The incremental relative opening and closing and mid ordinate deviation for various probabilities at a distance of approximately 1.43 kilometres from an active longwall are summarised in Table 6.

**Table 6 Incremental Relative Opening, Closing and Mid-Ordinate Deviation at Approximately 1.43 kilometres Distance from Active Longwall**

	1 in 20 probability (95% confidence level)	1 in 100 probability (99% confidence level)	1 in 2000 probability (99.95% confidence level)
Opening	4 mm	7 mm	14 mm
Closing	5 mm	9 mm	19 mm
Mid-Ordinate Deviation	7 mm	10 mm	18 mm

At this distance, adverse impact to Cawley Road Overpass resulting from the extraction of Longwalls 301 to 303 is considered unlikely, however an assessment of the structure should be undertaken to assess the sensitivity of the structure to potential differential movements a result of Longwalls 301 to 303.

## Summary

The M1 Princes Motorway is located greater than 210 metres to the east of Longwalls 301 to 303. The previous experience from the Southern Coalfield has found that the potential impacts on bitumen seal and asphaltic pavements can be managed with the implementation of suitable monitoring and management strategies.

It is recommended that monitoring and management strategies are developed, in consultation with RMS, to manage the potential impacts on the M1 Princes Motorway. It is expected that the motorway can be maintained in safe and serviceable conditions with the implementation of the appropriate monitoring and management strategies.

Bridge 2 is located approximately 330 metres from Longwall 301. A program of high accuracy monitoring of this bridge has been implemented by the RMS technical committee and will be outlined in the Built Features Management Plan for Longwalls 301 to 303. The culverts and Cawley Road Overpass are located outside the predicted 20 mm subsidence contour. Whilst these features could experience low level far-field horizontal movements, they are not expected to experience measurable strains or differential horizontal movements. Assessment of these structures should be undertaken by the RMS technical committee to assess the sensitivity of these structures to potential differential movements a result of Longwalls 301 to 303.

Yours sincerely

Peter DeBono

Mine Subsidence Engineering Consultants

Attachments:

Drawing No. MSEC844-08 – Longwalls 301 to 303 – RMS Infrastructure



Suite 402, 13 Spring Street, Chatswood NSW 2067  
 PO Box 302, Chatswood NSW 2057  
 Tel +61 2 9413 3777  
 www.minesubsidence.com



**METROPOLITAN COAL**  
 METROPOLITAN COLLIERY  
 LONGWALLS 301 TO 303  
 RMS

DATE: 23 Aug 2016	SCALE: 1:12500	DRAWING No: MSEC844-08	Rev No A
----------------------	-------------------	---------------------------	-------------

6 218 000

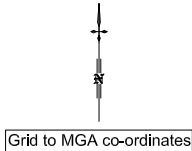

WORONORA RESERVOIR

6 217 000

6 216 000

6 215 000

20mm SUBSIDENCE CONTOUR

OLD PRINCES HIGHWAY

LW303

LW302

LW301

STUDY AREA

1430m

330m

PRINCES HIGHWAY UNDERPASS (BRIDGE 2)

CAWLEY ROAD OVERPASS

METROPOLITAN FAULT

CAWLEYS CK

EMBANKMENT

CUTTING 13563

CUTTING 10425

CUTTING 13562

CUTTING 10426

M1 PRINCES MOTORWAY

CUTTING 13561

CUTTING 10427

EMBANKMENT

WILSONS CK

LEGEND

- RMS INFRASTRUCTURE- M1 PRINCES MOTORWAY
- BRIDGES
- CUTTINGS
- EMBANKMENTS
- CULVERTS
- GEOLOGICAL FAULTS AT SEAM LEVEL

FAULT

MAIN WEST FAULT

POWELL FAULT

313 000

314 000

APPENDIX 2

MSEC (2019) METROPOLITAN COLLIERY – PROPOSED LONGWALL 304 -  
SUBSIDENCE PREDICTIONS AND IMPACT ASSESSMENTS FOR THE ROADS AND  
MARITIME SERVICES INFRASTRUCTURE

Metropolitan Coal – LW305-307 Built Features Management Plan – Roads and Maritime Services		
Revision No. BFMP_TFNSW-R01-D	ME-TSE-MNP-0088	
Document ID: Built Features Management Plan - TFNSW		

12<sup>th</sup> February 2019

Jon Degotardi  
Peabody Energy Australia  
Metropolitan Colliery  
PO Box 402  
Helensburgh NSW 2508

Ref: MSEC1013-08

Dear Jon,

**RE: Metropolitan Colliery – Proposed Longwalls 304 - Subsidence Predictions and Impact Assessments for the Roads and Maritime Services Infrastructure**

Metropolitan Coal is a wholly owned subsidiary of Peabody Energy Pty Limited (Peabody) and operates Metropolitan Colliery (the Colliery), which is located in the Southern Coalfield of New South Wales. Metropolitan Coal has extracted Longwalls 1 to 27, 301 and 302 at the Colliery and, at the time of this report, was extracting Longwall 303. The Roads and Maritime Services (RMS) infrastructure has been managed during the extraction of Longwalls 301 to 303 by a Technical Committee and in accordance with the Built Features Management Plan for RMS (LW301-303 BFMP\_RMS-R01-H).

In October 2018, Metropolitan Coal submitted an application to the DP&E to amend the first workings layout of Longwalls 304-306. The amended longwall layout included:

- uniform void panel width of 163 m and uniform solid tailgate pillar width of 45 m for Longwall 304 with a void panel length of 1,438 m;
- uniform void panel width of 138 m and uniform solid tailgate pillar width of 45 m for Longwall 305; and
- uniform void panel width of 138 m and uniform solid tailgate pillar width of 70 m for Longwalls 306.

DP&E's approval of the first workings application (granted in November 2018) requires Metropolitan Coal to commit to an appropriate setback of Longwall 304 from the Eastern Tributary and a detailed cumulative subsidence assessment including Longwalls 304 to 308 for the Eastern Tributary.

MSEC prepared report MSEC1009 to support the Longwall 304 Extraction Plan. The predictions and impact assessments provided in the report are based on the Extraction Plan Layout, defined as:

- the approved Longwalls 301 to 303 layout incorporating a proposed additional 182 m of secondary extraction of Longwall 303 (i.e. a longwall length of 1,325 m); and
- uniform void panel width of 163 m and uniform solid tailgate pillar widths of 45 m for Longwall 304 with a void panel length of 1,285 m.

This letter report summarises the predicted subsidence movements and the assessed subsidence impacts for the Roads and Maritime Services (RMS) infrastructure resulting from the extraction of the proposed Longwalls 304 at Metropolitan Colliery.

The locations of the RMS infrastructure and the proposed longwalls are shown in the attached Drawing No. MSEC1013-08. The M1 Princes Motorway is located to the east of Longwall 304. The distance of the M1 Princes Motorway from Longwalls 304 varies from 850 m near the finishing (southern) end to 930 m near the commencing (northern) end of Longwall 304. Longwalls 301 to 303 are located closer to the M1 Princes Motorway

with 210 metres distance to the finishing (southern) end of Longwall 301 and 335 metres distance to the commencing (northern) end of Longwall 301.

A series of cuttings and embankments up to a maximum height of approximately 20 metres are shown in the attached Drawing No. MSEC1013-08. A summary of the rock cuttings is provided in Table 1.

**Table 1 Summary of RMS Rock Cuttings**

RMS Slope Number	RMS Assessed Risk Level (ARL)	Length (m)	Maximum Slope Height (m)	Average Slope Angle (degrees)
13563	2	202	17	65
13562	3	531	18	70
13561	4	599	13	62
13560	3	231	8	70
10425	3	188	9	66
10426	4	503	15	55
10427	4	452	14	55
10428	4	192	9	65

A bridge is located at the crossing of the M1 Princes Motorway with the Old Princes Highway (Bridge 2), and is located approximately 890 metres from Longwall 304. The next nearest bridge is Cawley Road Overpass, which is located approximately 1.67 kilometres to the commencing end of Longwall 304.

A series of culverts cross the M1 Princes Motorway, as shown on Drawing No. MSEC1013-08. The culverts comprise pipes of varying diameters from 375 mm to 1800 mm. The pipe materials comprise asbestos cement (pipes up to 600 mm diameter) and steel reinforced concrete (pipes up to 1800 mm diameter). In addition to the culverts, there are also a number of other drainage structures, such as kerbs, gutters, pits and drainage pipes. The largest culvert comprises two 1800mm pipes located to the north east of the longwalls at Cawley's Creek.

The predictions and impact assessments for the RMS infrastructure are provided in the following sections.

### **Conventional Subsidence Parameters for the RMS Infrastructure**

The Study Area for Longwall 304 is defined as the surface area that is likely to be affected by the proposed mining of these longwalls (i.e. from conventional subsidence) and is based on the further extents of a 35° angle of draw line from the proposed extents of the longwalls and the predicted 20 mm subsidence contour resulting from the extraction of Longwall 304. The study area and the predicted 20mm subsidence contour for the extraction of Longwall 304 is shown in Drawing No. MSEC1013-08.

At over 850m from Longwall 304, the RMS assets are located outside the Study Area and are not expected to experience measurable conventional vertical subsidence, tilts, curvatures or strains (i.e. no greater than survey accuracy). The RMS assets could however experience low level far-field horizontal movement.

The observed incremental far-field horizontal movements, resulting from the extraction of longwalls in the Southern Coalfield, are provided in Figure 1. The data are based on survey marks located in areas influenced by previously extracted longwall panels.

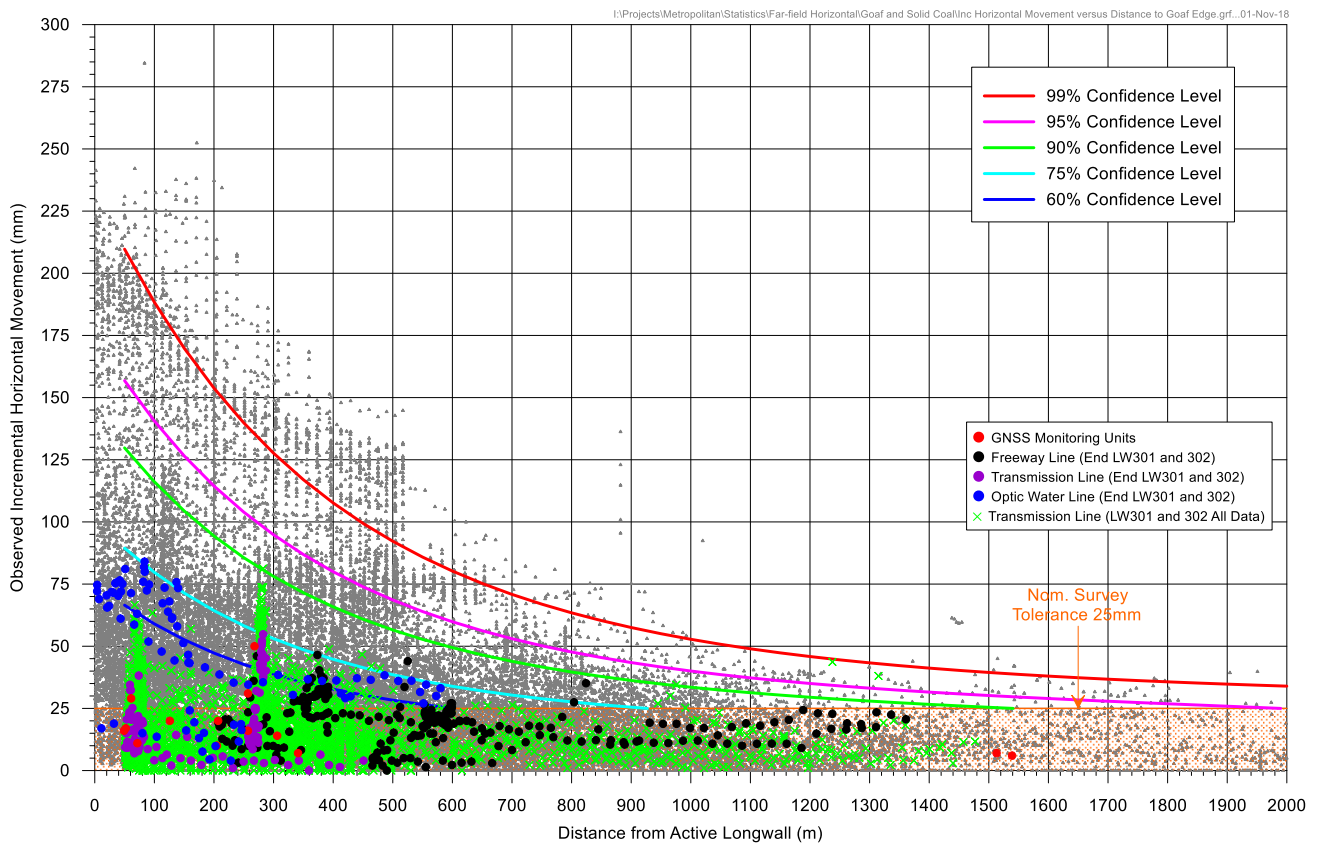

**Figure 1 Observed Incremental Far-field Horizontal Movements from the Southern Coalfield**

The observed horizontal movements during the extraction of Longwalls 301 and 302 are also plotted in Figure 1. The absolute horizontal movements measured at distances greater than 850 metres from mining are in the order of 45 mm based on the 95 % confidence level. These low level movements comprise a large proportion of survey tolerance. Far-field horizontal movements tend to be bodily movements orientated towards the mining area. The strains associated with these low level horizontal movement are not expected to be measurable.

**Potential for Non-Conventional Movements**

Non-conventional movements can develop due to the presence of geological structures or valley related effects. In some cases, non-conventional movements can develop with no known cause and these are often referred to as ‘anomalous’ movements.

The locations of the known geological structures at seam level and the major streams are shown in Drawing No. MSEC982-08. There are no identified geological structures within the Study Area that extend beneath the M1 Princes Motorway. The M1 Princes Motorway crosses the Metropolitan Fault approximately 960m from Longwall 304 and faults to the south east of Longwalls 304 are approximately 850m at the location of the M1 Princes Motorway. It is noted that these faults are identified at seam level and surface expression of faults may occur at different locations, or faults may not have continuity to the ground surface.

A small drainage line crosses the M1 Princes Motorway approximately 850m east of the finishing end of Longwall 304. A second drainage line is located to the north of the longwalls at Cawley’s Creek and is 1.3km from LW304). At these distance, the culverts are not predicted to experience valley related movements greater than survey accuracy, due to the extraction of Longwall 304.

Valley closure is not expected to occur in the cuttings along the M1 Princes Motorway, however, minor closure movements could be observed due to differential horizontal movements.

## Impact Assessments for the RMS Infrastructure

The M1 Princes Motorway is located more than 850m from Longwall 304 and is outside the Study Area boundary for this longwall.

The motorway (including bridges and associated features) is not expected to experience measurable conventional vertical subsidence, tilt, curvature and strain. The M1 Princes Motorway could experience far-field horizontal movements resulting from the extraction of the Longwall 304 of up to 45 mm, based on the 95% confidence level for observed far-field horizontal movement data for the Southern Coalfield.

Adverse impacts to the M1 Princes Motorway, including the road pavement, slopes, culverts, barriers and furniture, resulting from conventional subsidence movements is considered unlikely to occur due to the extraction of Longwall 304.

Bridge 2 (RMS reference BN616-southbound and BN617-northbound) is located approximately 880 m to the south east of Longwall 304 as shown in Drawing No. MSEC1013-08. The next nearest bridge is Cawleys Rd overpass (RMS reference BN615), located approximately 1.67 km from Longwall 304.

The potential for differential horizontal movement at the bridges was assessed by analysing the far-field horizontal movement data. The data set was analysed to determine incremental relative opening and closing and incremental mid ordinate deviation.

Relative opening and closing movement is calculated as the change in the distance between two survey marks (either positive opening, or negative closing) over two survey epochs.

A plot of the calculated incremental relative opening and closing movement for the current database of observed far-field horizontal movements that were used for this assessment is provided in Figure 2. The incremental relative opening and closing movement was calculated for pegs with a spacing of 20 m  $\pm$ 10 m.

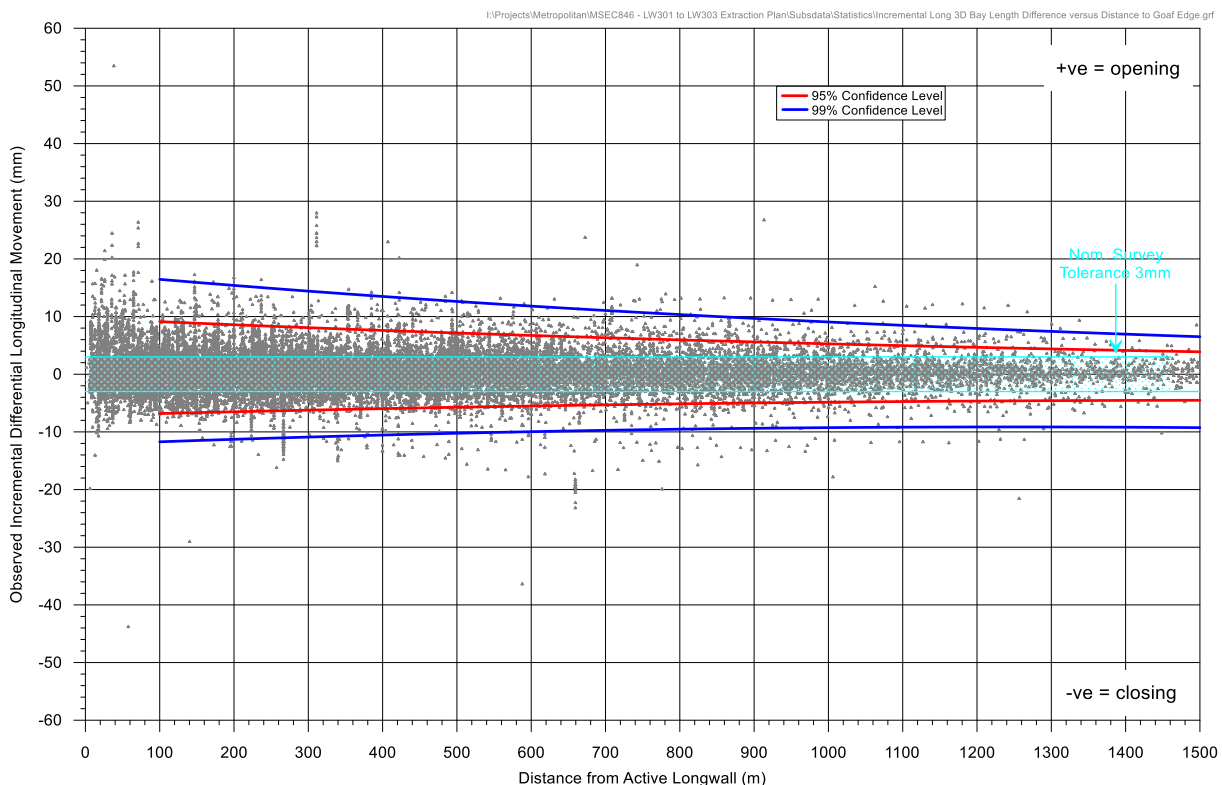

**Figure 2 Incremental Differential Horizontal Movements versus Distance from Active Longwall for Marks Spaced at 20 m  $\pm$ 10 m**

Mid ordinate deviation provides a measure of out of plane movement or horizontal bending by calculating the mid ordinate deviation between three survey pegs. The mid ordinate deviation is the change in perpendicular horizontal distance from a point to a chord formed by points on either side. A schematic sketch of the mid ordinate deviation is provided in Figure 3

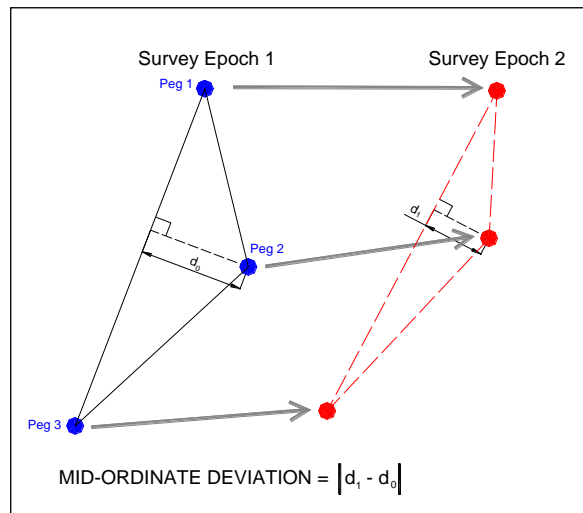

**Figure 3 Schematic Representation of Mid Ordinate Deviation**

A plot of the calculated incremental mid-ordinate deviation for the current database of observed far-field horizontal movements that were used for this assessment is provided in Figure 4. The mid-ordinate deviation was calculated for pegs with a spacing of  $20\text{ m} \pm 10\text{ m}$ , or an approximate spacing of 40 m over the three pegs.

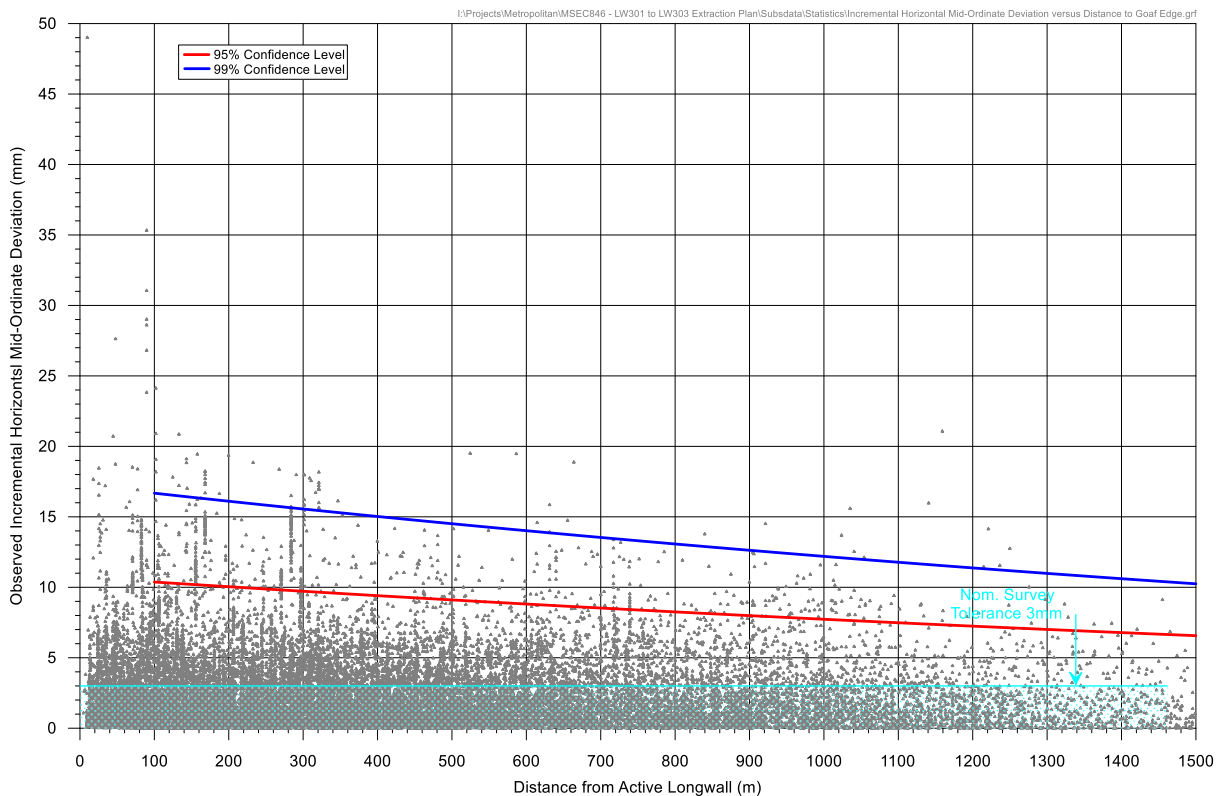

**Figure 4 Observed Incremental Mid Ordinate Deviation versus Distance from Active Longwall for Marks Spaced at  $20\text{ m} \pm 10\text{ m}$**

The incremental relative opening and closing and mid ordinate deviation for various probabilities for Bridge 2 at a distance of approximately 880 metres from an active longwall are summarised in Table 2.

**Table 2 Incremental Relative Opening, Closing and Mid-Ordinate Deviation at Approximately 880 metres Distance from Active Longwall**

	1 in 20 probability (95% confidence level)	1 in 100 probability (99% confidence level)	1 in 2000 probability (99.95% confidence level)
Opening	6 mm	10 mm	20 mm
Closing	5 mm	10 mm	21 mm
Mid-Ordinate Deviation	8 mm	13 mm	18 mm

The incremental relative opening and closing and mid ordinate deviation for various probabilities for Cawleys Road Overpass at a distance of approximately 1.67 kilometres from an active longwall are summarised in Table 3.

**Table 3 Incremental Relative Opening, Closing and Mid-Ordinate Deviation at Approximately 1.67 kilometres Distance from Active Longwall**

	1 in 20 probability (95% confidence level)	1 in 100 probability (99% confidence level)	1 in 2000 probability (99.95% confidence level)
Opening	4 mm	7 mm	14 mm
Closing	5 mm	9 mm	19 mm
Mid-Ordinate Deviation	7 mm	10 mm	16 mm

An assessment of Bridge 2 and Cawleys Road overpass by Cardno was undertaken for the extraction of Longwalls 301 to 303 and indicated that the bridges were sensitive to small differential movements. Given closer proximity of Bridge 2 to the extracted longwalls, a high accuracy monitoring system, using fibre optic monitoring, was implemented by the RMS technical committee to monitor movements at Bridge 2. A monitoring system for Cawleys Road overpass using fixed survey prisms was established.

It is recommended assessment of the bridges be undertaken by the RMS technical committee to review the suitability of the monitoring and management strategies that were developed for Longwalls 301 to 303.

## Summary

The M1 Princes Motorway is located greater than 850 metres to the east of Longwall 304. The two nearest bridges, Bridge 2 and Cawleys Road Overpass, are located 880 m and 1.67 km from Longwall 304 respectively. The RMS infrastructure is located outside the Study Area for Longwall 304. At these distances, the RMS infrastructure is not expected to experience measurable conventional subsidence movements but could experience low level far-field horizontal movements.

It is recommended that monitoring and management strategies developed for the extraction of Longwalls 301-303 are updated and continued, in consultation with RMS, to manage the potential impacts on the RMS infrastructure. It is expected that the RMS infrastructure can be maintained in safe and serviceable conditions with the implementation of the appropriate monitoring and management strategies.

Yours sincerely

Peter DeBono

Mine Subsidence Engineering Consultants

Attachments:

Drawing No. MSEC1013-08 – Longwall 304 – RMS



Suite 402, 13 Spring Street, Chatswood NSW 2067  
 PO Box 302, Chatswood NSW 2057  
 Tel +61 2 9413 3777  
 www.minesubsidence.com



**METROPOLITAN COAL**  
 METROPOLITAN COLLIERY  
 LONGWALL 304  
 RMS

DATE: 12 Mar 2019	SCALE: 1:12500	DRAWING No: MSEC1013-08	Rev No 02
----------------------	-------------------	----------------------------	--------------

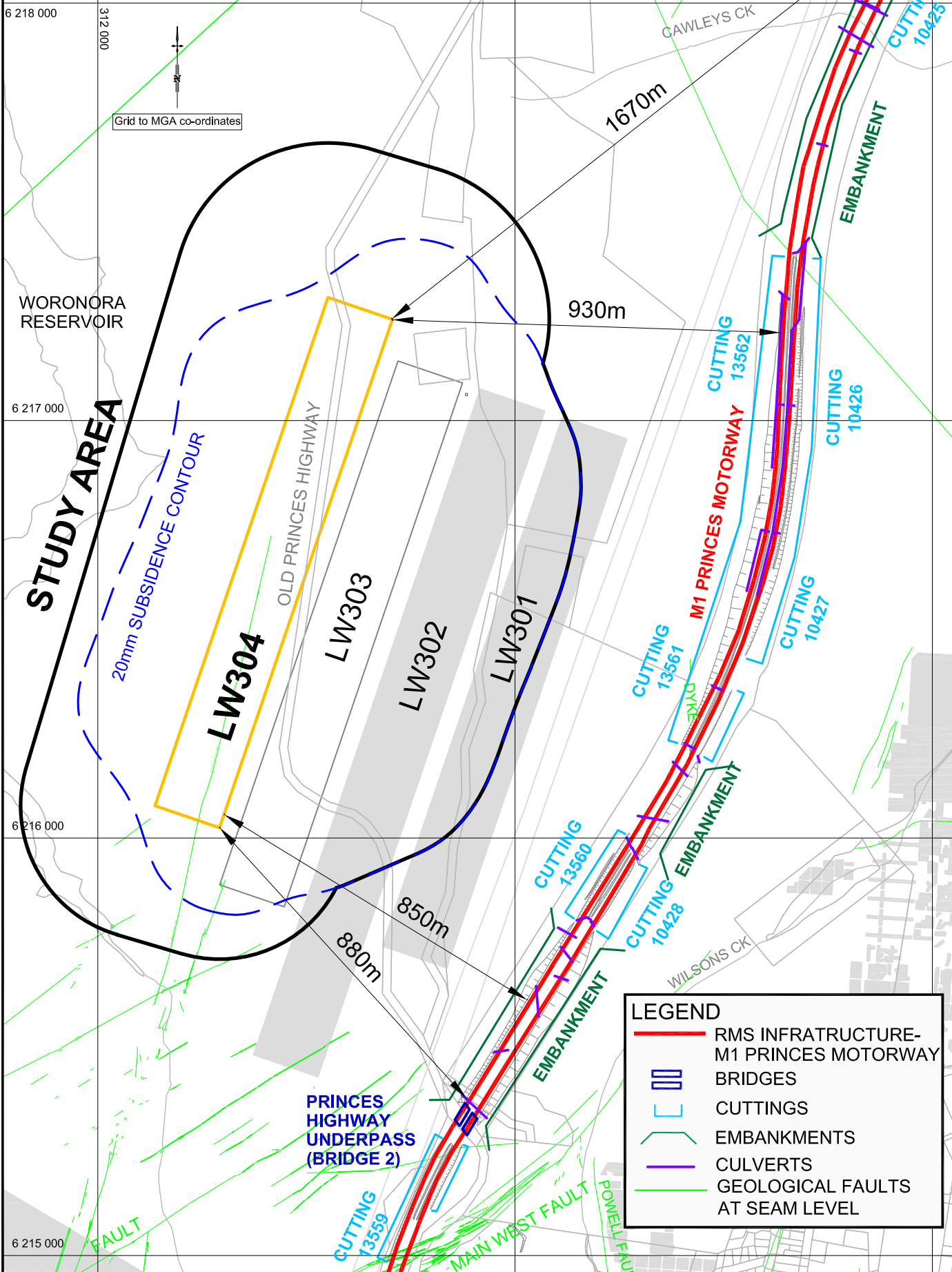

LEGEND	
	RMS INFRASTRUCTURE- M1 PRINCES MOTORWAY
	BRIDGES
	CUTTINGS
	EMBANKMENTS
	CULVERTS
	GEOLOGICAL FAULTS AT SEAM LEVEL

APPENDIX 3

MSEC (2019) METROPOLITAN COLLIERY – PROPOSED LONGWALLS 305 TO 307 -  
SUBSIDENCE PREDICTIONS AND IMPACT ASSESSMENTS FOR THE ROADS AND  
MARITIME SERVICES INFRASTRUCTURE

Metropolitan Coal – LW305-307 Built Features Management Plan – Roads and Maritime Services		
Revision No. BFMP_TFNSW-R01-D	ME-TSE-MNP-0088	
Document ID: Built Features Management Plan - TFNSW		

05<sup>th</sup> August 2019

Jon Degotardi  
Peabody Energy Australia  
Metropolitan Colliery  
PO Box 402  
Helensburgh NSW 2508

Ref: MSEC1059-08

Dear Jon,

**RE: Metropolitan Colliery – Proposed Longwalls 305 to 307 - Subsidence Predictions and Impact Assessments for the Roads and Maritime Services Infrastructure**

Metropolitan Coal is a wholly owned subsidiary of Peabody Energy Pty Limited (Peabody) and operates Metropolitan Colliery (the Colliery), which is located in the Southern Coalfield of New South Wales. Metropolitan Coal has extracted Longwalls 1 to 27, 301 to 303 at the Colliery and, at the time of this report, had commenced extraction of Longwall 304. The Roads and Maritime Services (RMS) infrastructure has been managed during the extraction of Longwalls 301 to 304 by a Technical Committee and in accordance with the Built Features Management Plan for RMS.

This letter report summarises the predicted subsidence movements and the assessed subsidence impacts for the Roads and Maritime Services (RMS) infrastructure resulting from the extraction of the proposed Longwalls 304 at Metropolitan Colliery.

The locations of the RMS infrastructure and the proposed longwalls are shown in the attached Drawing No. MSEC1059-08. The M1 Princes Motorway is located to the east of Longwall 305. The distance of the M1 Princes Motorway from Longwalls 305 varies from 1040 m near the finishing (southern) end to 1,100 m near the commencing (northern) end of Longwall 305. Longwalls 301 to 304 are located closer to the M1 Princes Motorway with 210 metres distance to the finishing (southern) end of Longwall 301 and 335 metres distance to the commencing (northern) end of Longwall 301.

A series of cuttings and embankments up to a maximum height of approximately 20 metres are shown in the attached Drawing No. MSEC1059-08. A summary of the rock cuttings is provided in Table 1.

**Table 1 Summary of RMS Rock Cuttings**

RMS Slope Number	RMS Assessed Risk Level (ARL)	Length (m)	Maximum Slope Height (m)	Average Slope Angle (degrees)
13563	2	202	17	65
13562	3	531	18	70
13561	4	599	13	62
13560	3	231	8	70
10425	3	188	9	66
10426	4	503	15	55
10427	4	452	14	55
10428	4	192	9	65

A bridge is located at the crossing of the M1 Princes Motorway with the Old Princes Highway (Bridge 2), and is located approximately 1,020 metres from Longwall 305. The next nearest bridge is Cawley Road Overpass, which is located approximately 1.67 kilometres to the commencing end of Longwall 305.

A series of culverts cross the M1 Princes Motorway, as shown on Drawing No. MSEC1059-08. The culverts comprise pipes of varying diameters from 375 mm to 1800 mm. The pipe materials comprise asbestos cement (pipes up to 600 mm diameter) and steel reinforced concrete (pipes up to 1800 mm diameter). In addition to the culverts, there are also a number of other drainage structures, such as kerbs, gutters, pits and drainage pipes. The largest culvert comprises two 1800mm pipes located to the north east of the longwalls at Cawley's Creek.

The predictions and impact assessments for the RMS infrastructure are provided in the following sections.

### Conventional Subsidence Parameters for the RMS Infrastructure

The Study Area for Longwall 304 is defined as the surface area that is likely to be affected by the proposed mining of these longwalls (i.e. from conventional subsidence) and is based on the further extents of a 35° angle of draw line from the proposed extents of the longwalls and the predicted 20 mm subsidence contour resulting from the extraction of Longwalls 305 to 307. The study area and the predicted 20mm subsidence contour for the extraction of Longwall 304 is are shown in Drawing No. MSEC1059-08.

At over 1,020 m from Longwall 305, the RMS assets are located outside the Study Area and are not expected to experience measurable conventional vertical subsidence, tilts, curvatures or strains (i.e. no greater than survey accuracy). The RMS assets could however experience low level far-field horizontal movement.

The observed incremental far-field horizontal movements, resulting from the extraction of longwalls in the Southern Coalfield, are provided in Figure 1. The data are based on survey marks located in areas influenced by previously extracted longwall panels.

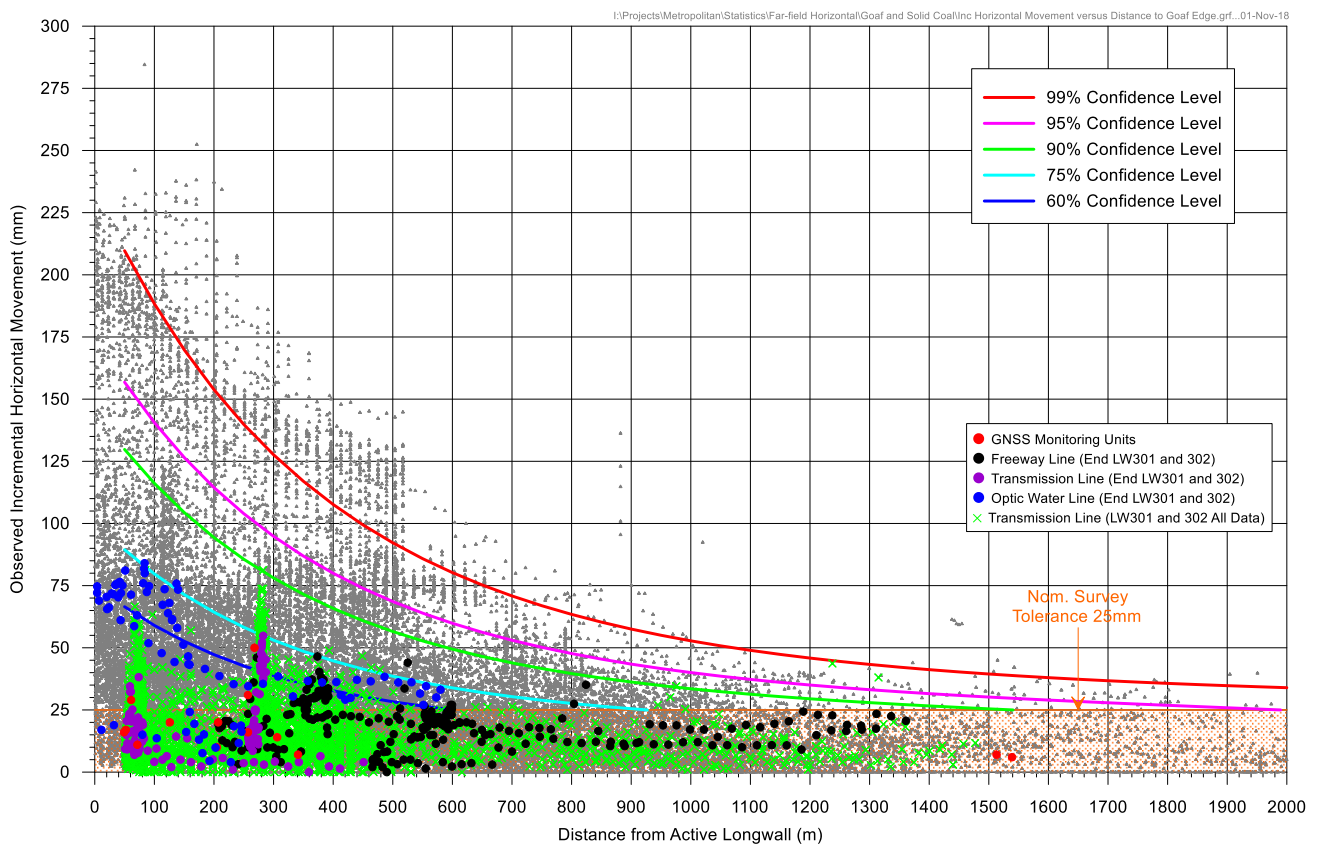

**Figure 1 Observed Incremental Far-field Horizontal Movements from the Southern Coalfield**

The observed horizontal movements during the extraction of Longwalls 301 and 302 are also plotted in Figure 1. The absolute horizontal movements measured at distances greater than 1,020 metres from mining are in the order

of 40 mm based on the 95 % confidence level. These low level movements comprise a large proportion of survey tolerance. Far-field horizontal movements tend to be bodily movements orientated towards the mining area. The strains associated with these low level horizontal movement are not expected to be measurable.

### **Potential for Non-Conventional Movements**

Non-conventional movements can develop due to the presence of geological structures or valley related effects. In some cases, non-conventional movements can develop with no known cause and these are often referred to as 'anomalous' movements.

The locations of the known geological structures at seam level and the major streams are shown in Drawing No. MSEC982-08. There are no identified geological structures within the Study Area that extend beneath the M1 Princes Motorway. The M1 Princes Motorway crosses the Metropolitan Fault approximately 1,100m from Longwall 305. It is noted that the faults shown in Drawing No. MSEC982-08 are identified at seam level and surface expression of faults may occur at different locations, or faults may not have continuity to the ground surface.

A small drainage line crosses the M1 Princes Motorway approximately 1,020m east of the finishing end of Longwall 305. A second drainage line is located to the north of the longwalls at Cawley's Creek and is 1.35km from LW305). At these distance, the culverts are not predicted to experience valley related movements greater than survey accuracy, due to the extraction of Longwalls 305 to 307.

Valley closure is not expected to occur in the cuttings along the M1 Princes Motorway, however, minor closure movements could be observed due to differential horizontal movements.

### **Impact Assessments for the RMS Infrastructure**

The M1 Princes Motorway is located more than 1 km from Longwall 305 and is outside the Study Area boundary for Longwalls 305 to 307.

The motorway (including bridges and associated features) is not expected to experience measurable conventional vertical subsidence, tilt, curvature and strain. The M1 Princes Motorway could experience far-field horizontal movements resulting from the extraction of the Longwall 305 of up to 40 mm, based on the 95% confidence level for observed far-field horizontal movement data for the Southern Coalfield. The observed horizontal movements are however, expected to be less than these values. Observed horizontal movements have been recorded at several real time GNSS monitoring units located to the east of Longwalls 301 to 303. The observations to date show a maximum observed incremental horizontal movement of 15 mm at 1 km from an active longwall.

Adverse impacts to the M1 Princes Motorway, including the road pavement, slopes, culverts, barriers and furniture, resulting from conventional subsidence movements is considered unlikely to occur due to the extraction of Longwall 305 to 307.

Bridge 2 (RMS reference BN616-southbound and BN617-northbound) is located approximately 1,020 m to the south east of Longwall 305 as shown in Drawing No. MSEC1059-08. The next nearest bridge is Cawleys Rd overpass (RMS reference BN615), located approximately 1.67 km from Longwall 305.

The potential for differential horizontal movement at the bridges was assessed by analysing the far-field horizontal movement data. The data set was analysed to determine incremental relative opening and closing and incremental mid ordinate deviation.

Relative opening and closing movement is calculated as the change in the distance between two survey marks (either positive opening, or negative closing) over two survey epochs.

A plot of the calculated incremental relative opening and closing movement for the current database of observed far-field horizontal movements that were used for this assessment is provided in Figure 2. The incremental relative opening and closing movement was calculated for pegs with a spacing of 20 m  $\pm$ 10 m.

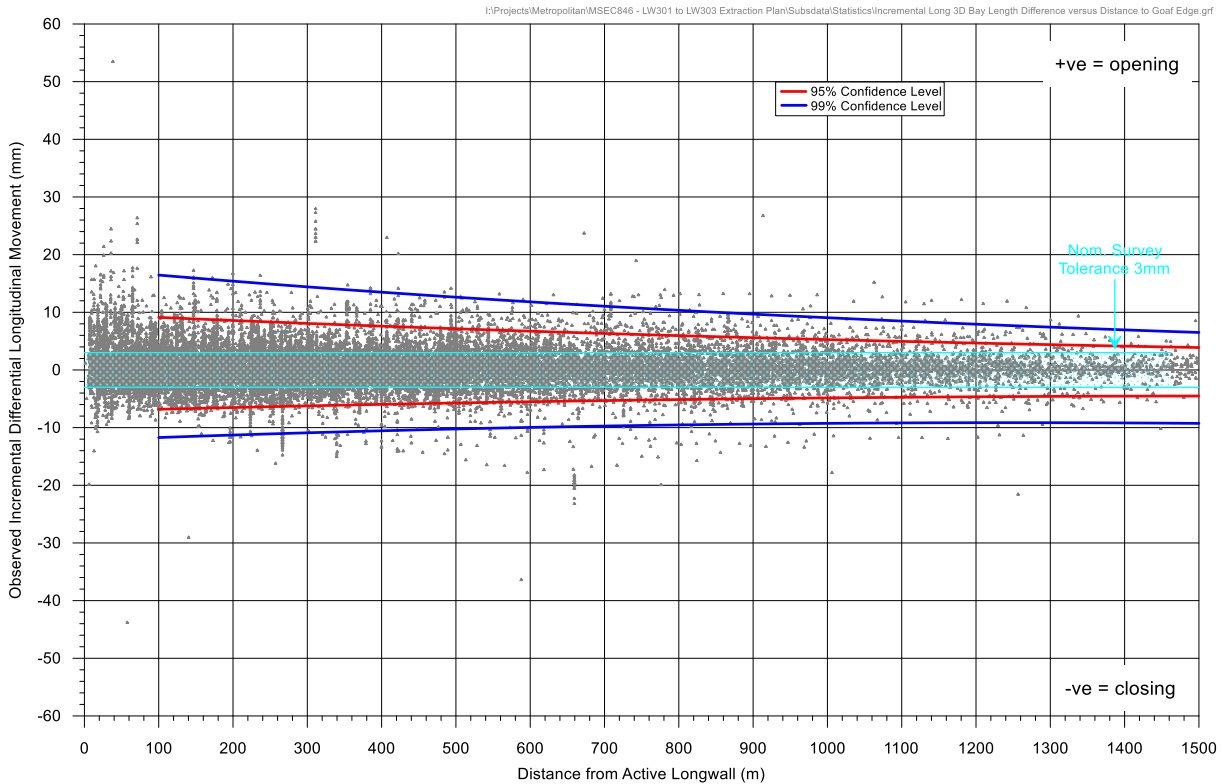

**Figure 2 Incremental Differential Horizontal Movements versus Distance from Active Longwall for Marks Spaced at 20 m ±10 m**

Mid ordinate deviation provides a measure of out of plane movement or horizontal bending by calculating the mid ordinate deviation between three survey pegs. The mid ordinate deviation is the change in perpendicular horizontal distance from a point to a chord formed by points on either side. A schematic sketch of the mid ordinate deviation is provided in Figure 3

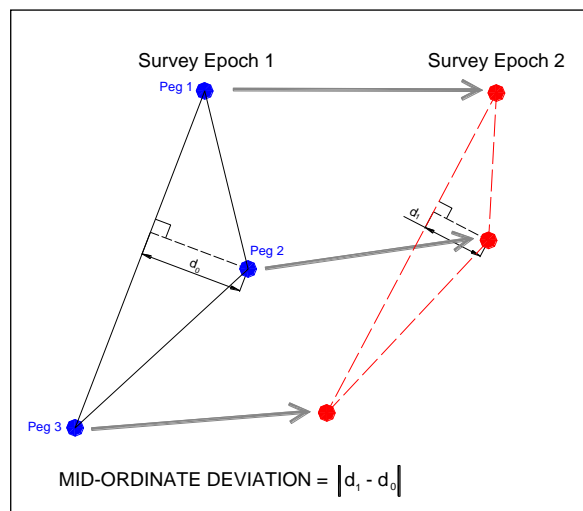

**Figure 3 Schematic Representation of Mid Ordinate Deviation**

A plot of the calculated incremental mid-ordinate deviation for the current database of observed far-field horizontal movements that were used for this assessment is provided in Figure 4. The mid-ordinate deviation was calculated for pegs with a spacing of 20 m ±10 m, or an approximate spacing of 40 m over the three pegs.

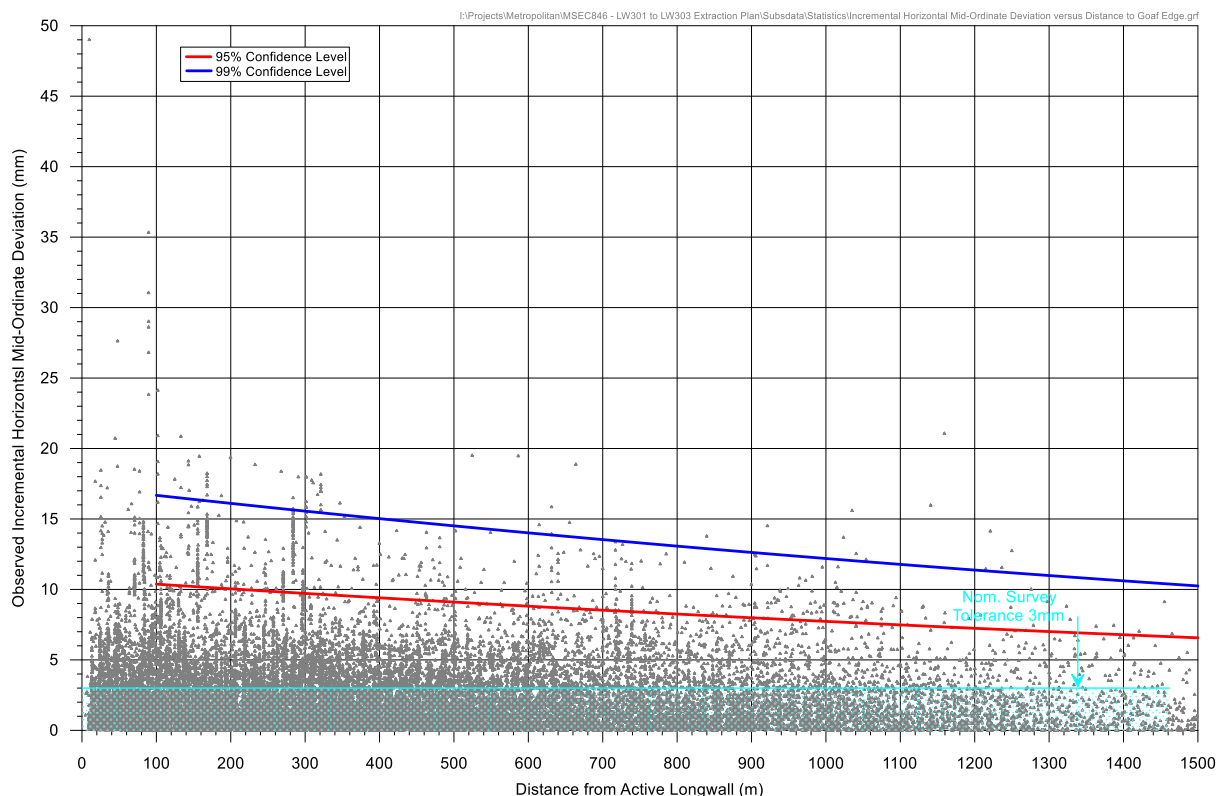

**Figure 4 Observed Incremental Mid Ordinate Deviation versus Distance from Active Longwall for Marks Spaced at 20 m ±10 m**

The incremental relative opening and closing and mid ordinate deviation for various probabilities for Bridge 2 at a distance of approximately 1,020 metres from an active longwall are summarised in Table 2.

**Table 2 Incremental Relative Opening, Closing and Mid-Ordinate Deviation at Approximately 880 metres Distance from Active Longwall**

	1 in 20 probability (95% confidence level)	1 in 100 probability (99% confidence level)	1 in 2000 probability (99.95% confidence level)
Opening	5 mm	9 mm	20 mm
Closing	5 mm	9 mm	21 mm
Mid-Ordinate Deviation	8 mm	12 mm	18 mm

The incremental relative opening and closing and mid ordinate deviation for various probabilities for Cawleys Road Overpass at a distance of approximately 1.67 kilometres from an active longwall are summarised in Table 3.

**Table 3 Incremental Relative Opening, Closing and Mid-Ordinate Deviation at Approximately 1.67 kilometres Distance from Active Longwall**

	1 in 20 probability (95% confidence level)	1 in 100 probability (99% confidence level)	1 in 2000 probability (99.95% confidence level)
Opening	4 mm	7 mm	14 mm
Closing	5 mm	9 mm	19 mm
Mid-Ordinate Deviation	7 mm	10 mm	16 mm

An assessment of Bridge 2 and Cawleys Road overpass by Cardno was undertaken for the extraction of Longwalls 301 to 303 and indicated that the bridges were sensitive to small differential movements. Given closer proximity of Bridge 2 to the extracted longwalls, a high accuracy monitoring system, using fibre optic monitoring, was implemented by the RMS technical committee to monitor movements at Bridge 2. A monitoring system for Cawleys Road overpass using fixed survey prisms was established.

It is recommended assessment of the bridges be undertaken by the RMS technical committee to review the suitability of the monitoring and management strategies that were developed for Longwalls 301 to 303.

### Summary

The M1 Princes Motorway is located greater than 1,020 metres to the east of Longwall 305. The two nearest bridges, Bridge 2 and Cawleys Road Overpass, are located 1,020 m and 1.67 km from Longwall 305 respectively. The RMS infrastructure is located outside the Study Area for Longwall 304. At these distances, the RMS infrastructure is not expected to experience measurable conventional subsidence movements but could experience low level far-field horizontal movements.

It is recommended that monitoring and management strategies developed for the extraction of Longwalls 301-304 are updated and continued, in consultation with RMS, to manage the potential impacts on the RMS infrastructure. It is expected that the RMS infrastructure can be maintained in safe and serviceable conditions with the implementation of the appropriate monitoring and management strategies.

Yours sincerely

Peter DeBono

Mine Subsidence Engineering Consultants

Attachments:

Drawing No. MSEC1059-08 – Longwall 305 to 307 – RMS

**msec**  
mine subsidence  
ENGINEERING CONSULTANTS

Suite 402, 13 Spring Street, Chatswood NSW 2067  
PO Box 302, Chatswood NSW 2057  
Tel +61 2 9413 3777  
www.minesubsidence.com

**METROPOLITAN COAL**  
METROPOLITAN COLLIERY  
LONGWALL 305  
RMS

DATE: 16 Jul 2019	SCALE: 1:12500	DRAWING No: MSEC1059-08	Rev No 01
----------------------	-------------------	----------------------------	--------------

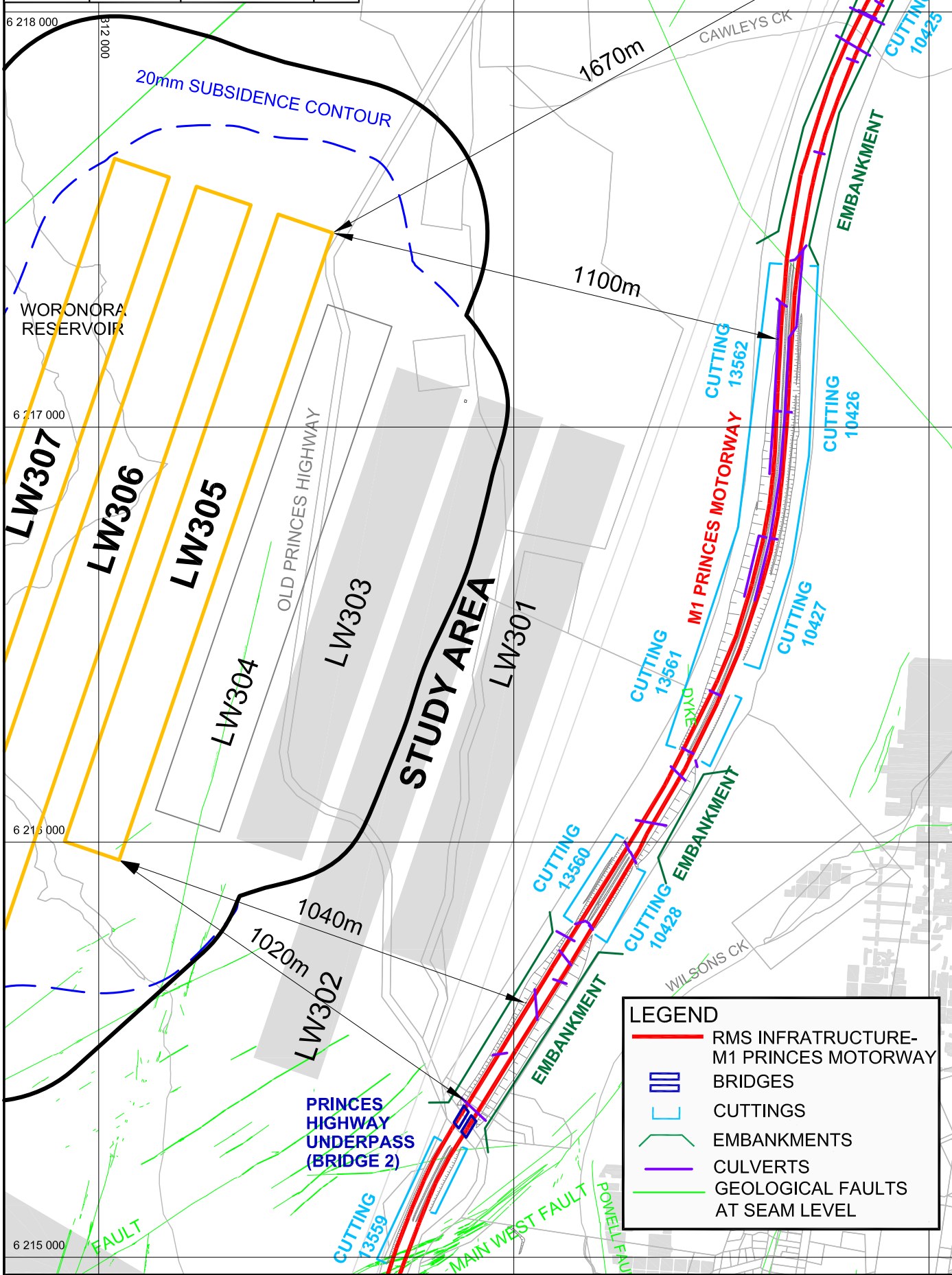

**LEGEND**

- RMS INFRASTRUCTURE- M1 PRINCES MOTORWAY
- BRIDGES
- CUTTINGS
- EMBANKMENTS
- CULVERTS
- GEOLOGICAL FAULTS AT SEAM LEVEL

APPENDIX 3A

MSEC (2021) METROPOLITAN COLLIERY – TfNSW-REVIEW OF SUBSIDENCE  
MONITORING FOR LW307 to LW310

Metropolitan Coal – LW305-307 Built Features Management Plan – Roads and Maritime Services		
Revision No. BFMP_TFNSW-R01-D	ME-TSE-MNP-0088	
Document ID: Built Features Management Plan - TFNSW		

7<sup>th</sup> December 2021

Level 1, 228 Victoria Avenue  
Chatswood NSW 2067  
PO Box 3047  
Willoughby North NSW 2068  
Tel +61 2 9413 3777  
Fax +61 2 9413 3822  
enquiries@minesubsidence.com  
www.minesubsidence.com



Jon Degotardi  
Helensburgh Coal Pty Ltd  
Metropolitan Colliery  
PO Box 402  
Helensburgh NSW 2508

Ref: MSEC1200-01A Revision A

Dear Jon,

**RE: Metropolitan Mine  
Review of monitoring along M1 Princes Motorway**

## 1. Background

Metropolitan Coal has extracted Longwalls 301 to 305 at Metropolitan Colliery and is currently extracting Longwall 306. Monitoring for Transport for NSW (TfNSW) assets has included terrestrial surveys along the road pavement, bridge structures and cuttings, FBG monitoring of Bridge 2, visual surveys, and GNSS monitoring along the transmission line easement to the west of the M1 Princes Motorway (the Motorway).

The Motorway has not been mined beneath by the 300 series longwalls and is located approximately 200m or more to the east of the 300 series longwalls. To date, monitoring has identified minor vertical subsidence and horizontal movement with no significant differential movement.

At the recent TfNSW Technical Committee meeting on 3 August 2021 (TCM2-21MC) it was decided that FBG monitoring of Bridge 2 was no longer required and would be decommissioned. With increasing distance between the extracted longwalls and the TfNSW assets, Metropolitan Colliery have requested Mine Subsidence Engineering Consultants (MSEC) to review the monitoring to date and assess future monitoring by terrestrial survey and GNSS, for review by TfNSW Technical Committee.

Following completion of the approved Longwalls 305 to 307, the next series of longwalls, 308 to 310 will be located at distances of approximately 1.6km to 1.9km from the Motorway. Longwall 307 is located approximately 1.4km to 1.9km from the Motorway and is scheduled for extraction in 2022. A layout of the longwalls with distances from future longwall panels is shown below in Fig. 1.1.

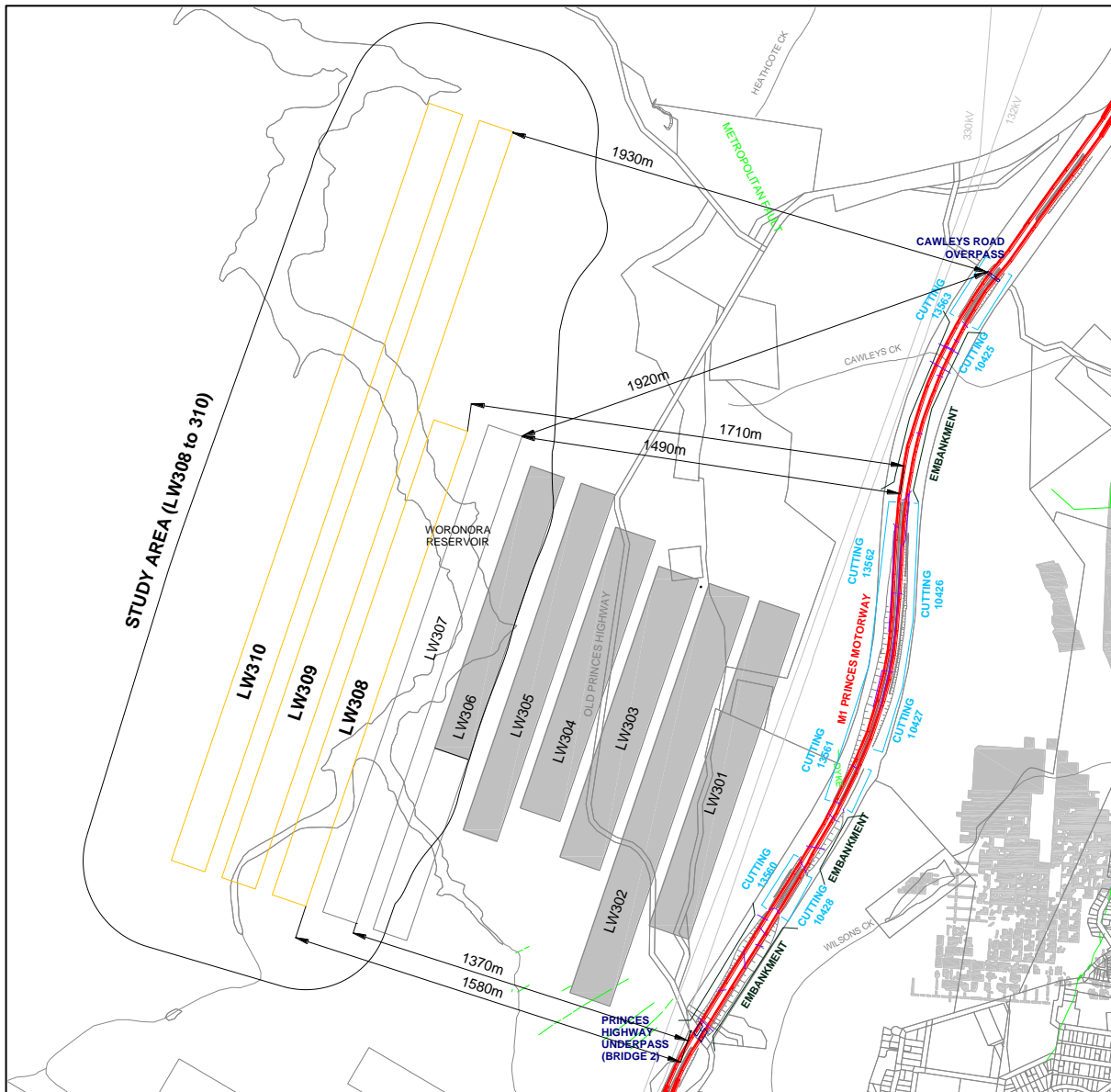

Fig. 1.1 Site Layout

## 2. Monitoring Data

The latest terrestrial survey of the Motorway (the Freeway Line) was undertaken 29 October 2021. The graphs showing observed incremental movements during Longwall 306 and total movements due to Longwalls 301 to 306 are shown below in Fig. 2.1 and Fig. 2.2 respectively. Surveys along the Motorway require significant forward planning and safety and are therefore difficult to carry out on a regular basis.

The observed incremental movements were within the limits of survey accuracy with a maximum observed vertical subsidence of 6mm. The observed total movements show minor subsidence of up to 51mm, with observed tilt within the limits of survey accuracy of 0.5mm/m. The observed total strain is also within the limits of survey accuracy with the exception of one survey measuring a compressive strain of 0.6mm/m on 27 Nov 2020. This survey is located between Survey Marks FW207 and 208 and is the location of a pavement defect which is discussed below. Mark FW207 has been destroyed so strain measurement at this location is not available for the latest survey.



Fig. 2.1 Observed Incremental Subsidence Movements

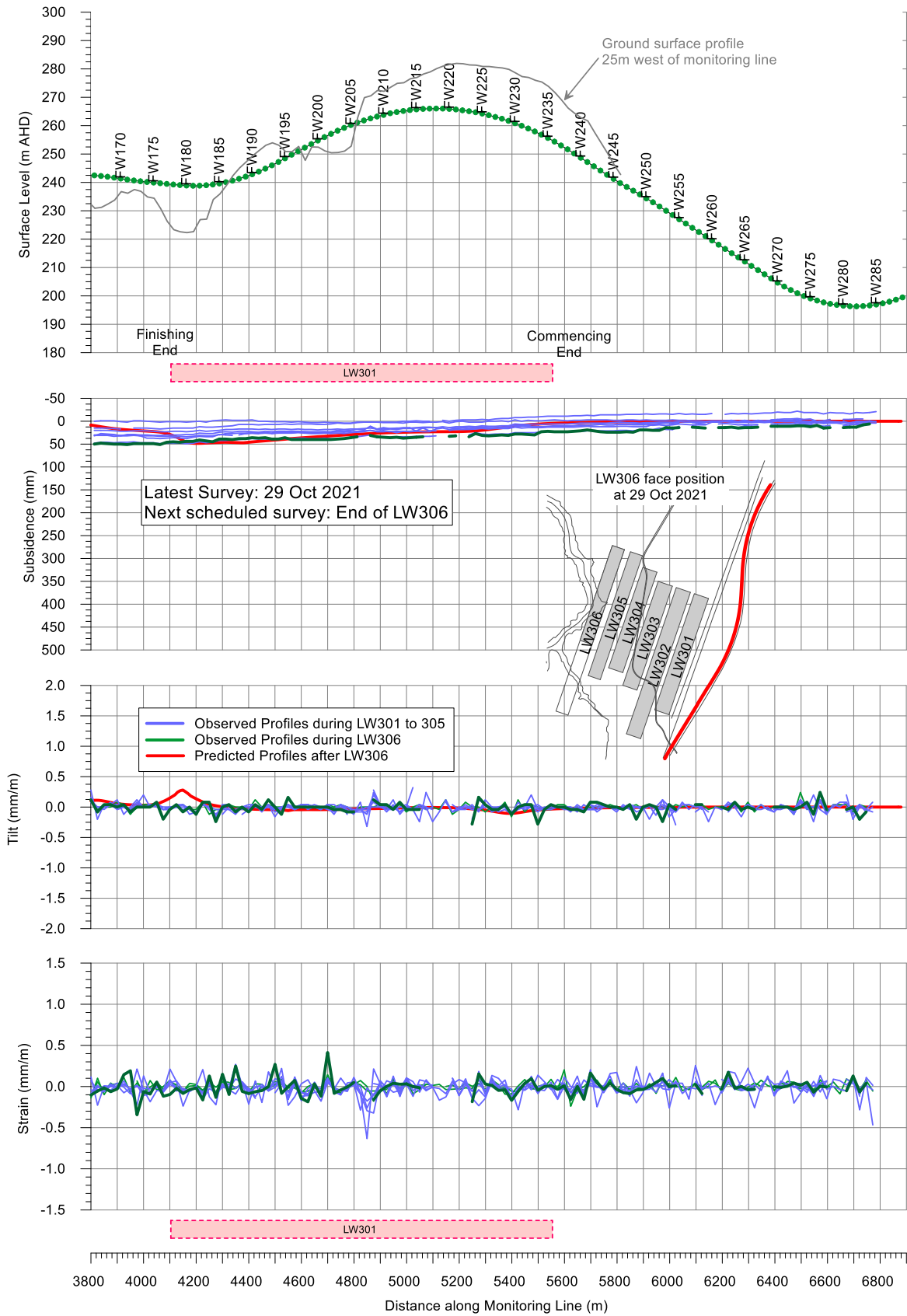

**Fig. 2.2 Observed Total Subsidence Movements**

Other terrestrial monitoring includes prism surveys of Bridge 2 and Cawleys Rd Bridge and cuttings along the freeway. Prism surveys of Bridge 2 were discontinued and replaced with high accuracy FBG monitoring. Prism surveys of Cawleys Rd Bridge and cuttings did not identify any significant movements and were troubled by vandalism.

GNSS monitoring points are located along a transmission easement to the west of the Motorway and are much closer to the extracted 300 series longwalls. The GSS monitoring provided high accuracy and continuous survey monitoring data including three dimensional movements and differential movements between marks. While some marks have been destroyed, the GNSS units have provided valuable data for ongoing assessment by the Technical Committee. The locations of the GNSS units used for assessment of the Motorway are shown in Fig. 1.1.

A copy of the latest GNSS monitoring data is shown in the monitoring status report for November in Attachment 1. The data shows negligible movements during the extraction of Longwalls 305 and 306. Minor vertical subsidence and horizontal movements are observed in GNSS04 and 05 during Longwall 305 however it is noted that these GNSS units are much closer to the extracted goaf. Minor horizontal movements may be observed in GNSS04 and 05 as Longwall 306 approaches completion.

### 3. Pavement Defect

As noted above one survey along the Freeway Line measured a compressive strain of 0.6mm/m on 27 Nov 2020. This survey is located between Survey Marks FW207 and 208 and is the location of a pavement defect which was initially identified during a visual survey undertaken by Comms Network Solutions Pty Ltd.

Assessments of the pavement defect and monitoring data by MSEC (2020) and AECOM (2020) identified a history of deterioration and repair well before longwall mining commenced near the location as well as the presence of a dyke, open joints and poor drainage close to the location of the defect. AECOM (2020) concluded:

*“Based on a review of the information provided in the references, it can be concluded that the overriding cause of the pavement defects identified at FW207.15 in the visual inspection report is an ongoing pavement subsurface drainage issue dating from before the commencement of mining.*

*The mining related ground movements are unlikely to have more than a minor influence on the groundwater issues at FW207.15.*

....

*It is recommended that permanent pavement rehabilitation only commence after the ongoing low order mining related movements in the area have effectively ceased.”*

### 4. Far-field Horizontal Movement

With increasing distance between the longwall mining operations and the Motorway the measured horizontal movements will continue to decrease. An empirical database of far-field horizontal movements for the NSW southern coalfield used for predictions of horizontal movements is shown in Fig. 4.1. The data presented includes locations with extracted longwalls between the monitored points and the active longwall, which represents the extraction scenario near the Motorway.

Monitoring data from the 300 series longwalls has been overlaid on the Southern Coalfield data in Fig. 4.1 with terrestrial survey line data in blue and GNSS data colour coded for each unit. To demonstrate the accuracy of the GNSS data, all daily monitoring points are shown for each GNSS unit with the maximum value for each longwall displayed in black. In addition to the GNSS units to the east of the longwalls, monitoring data for two additional units (39 and 40) located to the south west, are shown. Monitoring data for these units extends to over 3km from the extracted longwalls. A second graph to an enlarged scale (based on a 100mm maximum vertical axis) is shown in Fig. 4.2.

The data show that beyond approximately 1.6km, incremental horizontal movements are predominantly below 5mm, which is the typical limit of accuracy for the GNSS units. Below 1.6km, the horizontal movements increase with reducing distance to the extracted panel. An approximate upper limit of the observed GNSS data is shown in Fig. 4.2.

The distances from selected longwalls to Bridge 2 and Cawleys Road Bridge are shown in Fig. 4.1 and Fig. 4.2.

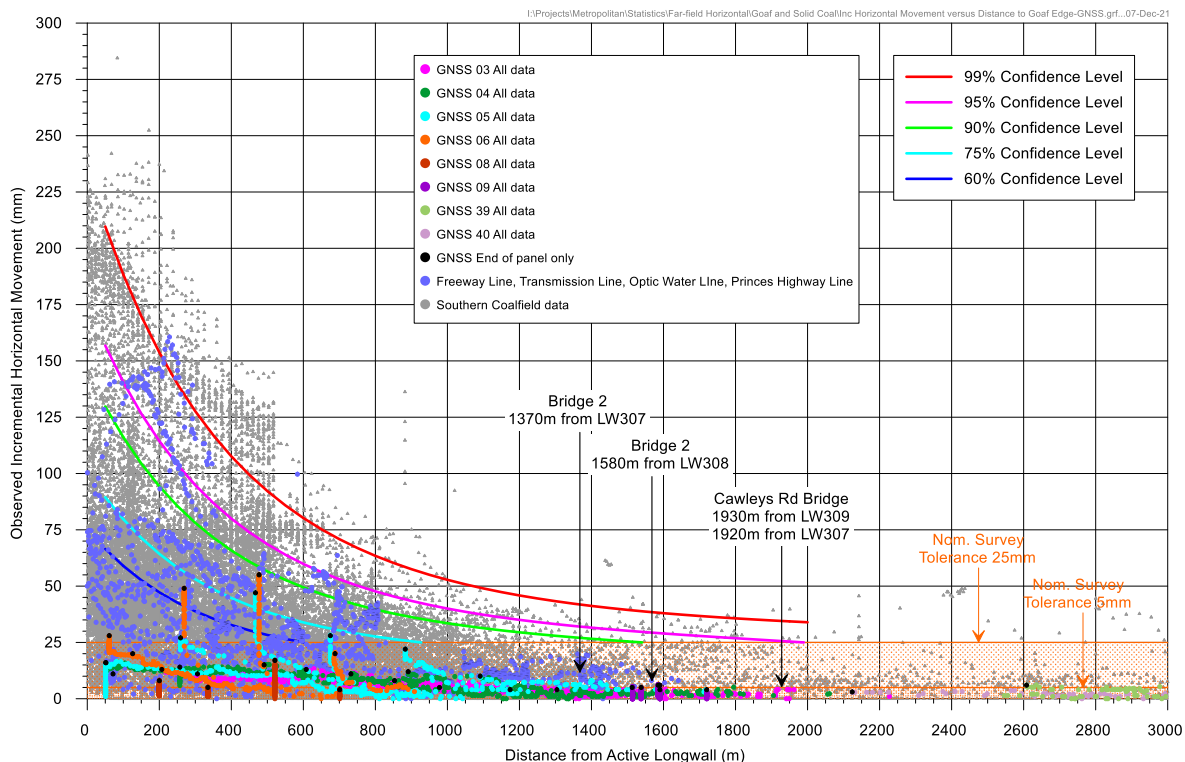

**Fig. 4.1 Observed Incremental Horizontal Movement versus Distance to Active Longwall**

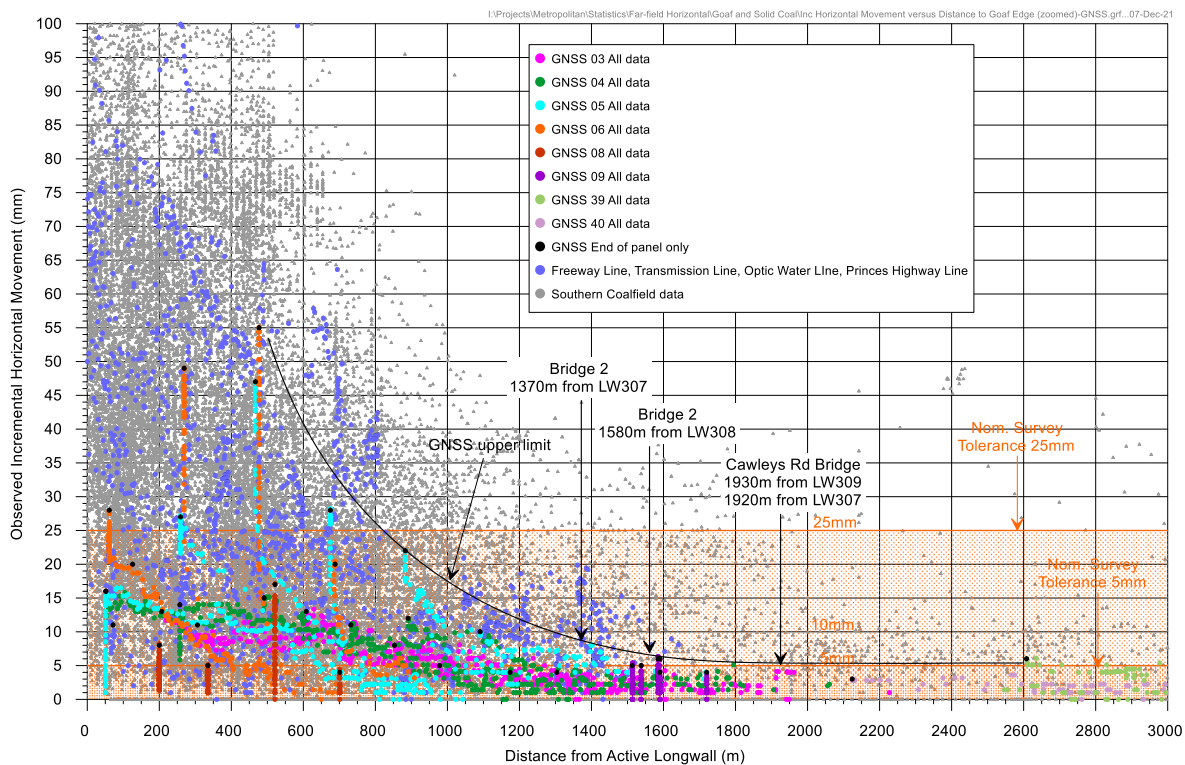

**Fig. 4.2 Observed Incremental Horizontal Movement versus Distance to Active Longwall (enlarged scale)**

## 5. Summary and Recommendations

The monitoring data observed to date has identified only minor vertical subsidence and horizontal movement at the M1 Princes Motorway with differential movement predominantly within the limits of survey accuracy. With increasing distance to future longwalls 307 and beyond, it is considered unlikely that any measurable subsidence movements will be observed using terrestrial survey methods. Minor horizontal movements are likely to be observed during LW307 and 308, beyond which most horizontal movements are expected to be within limits of accuracy of the GNSS units.

It is recommended that terrestrial surveys are discontinued beyond the completion of Longwall 306 and that continued monitoring utilises continuous GNSS monitoring units. The latest survey undertaken on 29 October 2021 was in anticipation of scheduled pavement maintenance that is expected to destroy a significant number of survey marks along the Freeway Line. Depending on the date of pavement maintenance, one further survey of the Freeway Line could be conducted at the completion of Longwall 306.

Ongoing monitoring of movements to the east of the 300 series longwalls could be assessed using the existing GNSS units, with the possibility of additional units closer to the M1 Princes Motorway. A suitable location for additional monitoring units would be either side of the geological structure near the identified pavement defect, to observe three dimensional movement and differential movement across the structure.

Consideration could also be given to reducing the frequency of reporting. It is considered that quarterly reporting would provide sufficient overview of the observed movements at the GNSS units.

Yours sincerely,



Peter DeBono  
Mine Subsidence Engineering Consultants

### *Attachments:*

Attachment A: Subsidence Management Monthly Status Report for November 2021 – TfNSW – RMS Built Features

### *References:*

AECOM 2020. AECOM Australia Pty Ltd. *Memorandum Metropolitan Coal – Assessment of pavement defects at FW207.15*. Reference 60546746 dated 27 July 2020

MSEC 2020. Mine Subsidence Engineering Consultants. *Metropolitan Mine – Review of subsidence along M1 Princes Motorway*. Reference MSEC1109-01 Rev A dated 2 June 2020.

# METROPOLITAN COLLIERY: Longwall 306

Subsidence Management Monthly Status Report for November 2021  
TfNSW - RMS Built Features



Reporting Period	01 to 30 November 2021	
Length of extraction (including installation headings of 8m)	1189 m	LW306 commenced 15 June 2021
Distance travelled by LW since previous report	274 m	
Face distance from Bridge 2	1350m	
Face distance from M1 Princes Motorway	1300m	
Maximum observed total subsidence along Freeway Line	51 mm	At mark FW171 and 176 Surveyed 29 Oct 2021 during LW306

## Summary of Monitoring and Inspections since Previous Report

Monitoring Activity	Frequency	Maximum Result	BFMP Tarp Status	Comments
<b>Bridge 2</b>				
GNSS Station 03 Incremental Horizontal Movement	10 sec – Averaged over 24hrs	1mm	Normal	
GNSS Station 03 Total Horizontal Movement		43mm	Normal	Movement direction NNW.
GNSS Station 03 Incremental Subsidence		-1mm	Normal	
GNSS Station 03 Total Subsidence		27mm	Normal	
<b>Cawley Rd Bridge</b>				
GNSS Station 09 Incremental Horizontal Movement	10 sec – Averaged over 24hrs	3mm	Normal	
GNSS Station 09 Total Horizontal Movement		11mm	Normal	
GNSS Station 09 Incremental Subsidence		1mm	Normal	
GNSS Station 09 Total Subsidence		-13mm	Normal	
<b>Pavements (M1 Princes Motorway) – Surveyed 27 November 2020 after LW305 Next scheduled survey at end of LW306</b>				
Total Subsidence (Freeway Line)	End of Panel unless otherwise determined by Technical Committee.	51mm	Normal	At mark FW171 and 176 – Surveyed 29 Oct 2021
Total Horizontal Movement (Freeway Line)		77mm	Normal	At mark FW229. Movement direction W. Surveyed 29 Oct 2021
Total Strain (Freeway Line)		Latest survey 27 Nov 2020	+0.4mm/m (tensile) -0.3mm/m (compressive)	Normal
TfNSW - RMS Network Safety Inspection	Twice weekly by TfNSW - RMS	No reports of impacts	N/A	Reporting by exception
Pavement Inspection	End of panel	Minor compression near FW207	N/A	Latest inspection 18 April 2020. Minor compression observed in gutter and shoulder near mark FW207.

Monitoring Activity	Frequency	Maximum Result (mm)	BFMP Tarp Status	Comments
<b>Cuttings (M1 Princes Motorway)</b>				
TfNSW - RMS Network Safety Inspection	Twice weekly by TfNSW - RMS	No reports of impacts	N/A	Reporting by exception
M1 Cutting closure marks Total Closure due to Longwall 303 to 305	End of Panel unless otherwise determined by Technical Committee.	-5mm (opening)	N/A	Marks reinstated during Longwall 303.
Visual Inspection	End of Panel unless otherwise determined by Technical Committee.		N/A	No survey undertaken since baseline.
<b>Culverts (M1 Princes Motorway)</b>				
CCTV Inspection	End of Panel unless otherwise determined by Technical Committee.		N/A	No survey undertaken since baseline.
<b>Data review by geotechnical and mine subsidence specialists</b>				
No review required. End of panel survey to be carried out in accordance with BFMP.				

Actions
<b>Actions since previous report:</b> <ul style="list-style-type: none"> <li>None.</li> </ul>
<b>Any additional and/or outstanding actions:</b> <ul style="list-style-type: none"> <li>None.</li> </ul>

Certified by Metropolitan Colliery	
Name	Jon Degotardi
Position	Technical Services Manager
Signature	
Date	7 December 2021

Attachments

Fig. 01 Profiles of total subsidence, tilt and strain along the Freeway Line due to Metropolitan Colliery LW301 to 306

Fig. 02 Observed Total Subsidence at GNSS Monitoring Stations

Fig. 03 GNSS Stations Total Horizontal Movement due to Longwall 301 to 306 – Site 03 and Site 09

Fig. 04 GNSS Stations Total Horizontal Movement due to Longwall 301 and 306

Fig. 05 Observed Opening and Closure between GNSS Monitoring Stations

Drawing No. MSEC1062-04 TfNSW - RMS Monitoring

**Copy of Report to:**

TfNSW - RMS – Metropolitan Colliery Technical Committee

Member	Organisation	Email
Dick Lee Shoy	Transport for NSW - Roads & Maritime Services (TfNSW – RMS)	<a href="mailto:dpleeshoy@aapt.net.au">dpleeshoy@aapt.net.au</a>
Cyril Gunaratne		<a href="mailto:Cyril.gunaratne@transport.nsw.gov.au">Cyril.gunaratne@transport.nsw.gov.au</a>
Dony Castro		<a href="mailto:Dony.D.Castro@transport.nsw.gov.au">Dony.D.Castro@transport.nsw.gov.au</a>
Matthew Montgomery	Subsidence Advisory NSW	<a href="mailto:matthew.montgomery@finance.nsw.gov.au">matthew.montgomery@finance.nsw.gov.au</a>
Henk Buys	Aecom	<a href="mailto:Henk.buys@aecom.com">Henk.buys@aecom.com</a>
Peter DeBono	Mine Subsidence Engineering Consultants	<a href="mailto:peter@minesubsidence.com">peter@minesubsidence.com</a>
Richard Woods	Cardno	<a href="mailto:Richard.woods@cardno.com.au">Richard.woods@cardno.com.au</a>
Jon Degotardi	Peabody	<a href="mailto:jdegotardi@peabodyenergy.com">jdegotardi@peabodyenergy.com</a>

# Profiles of Total Subsidence, Tilt and Strain along the Freeway Line due to Metropolitan Colliery LW301 to 306

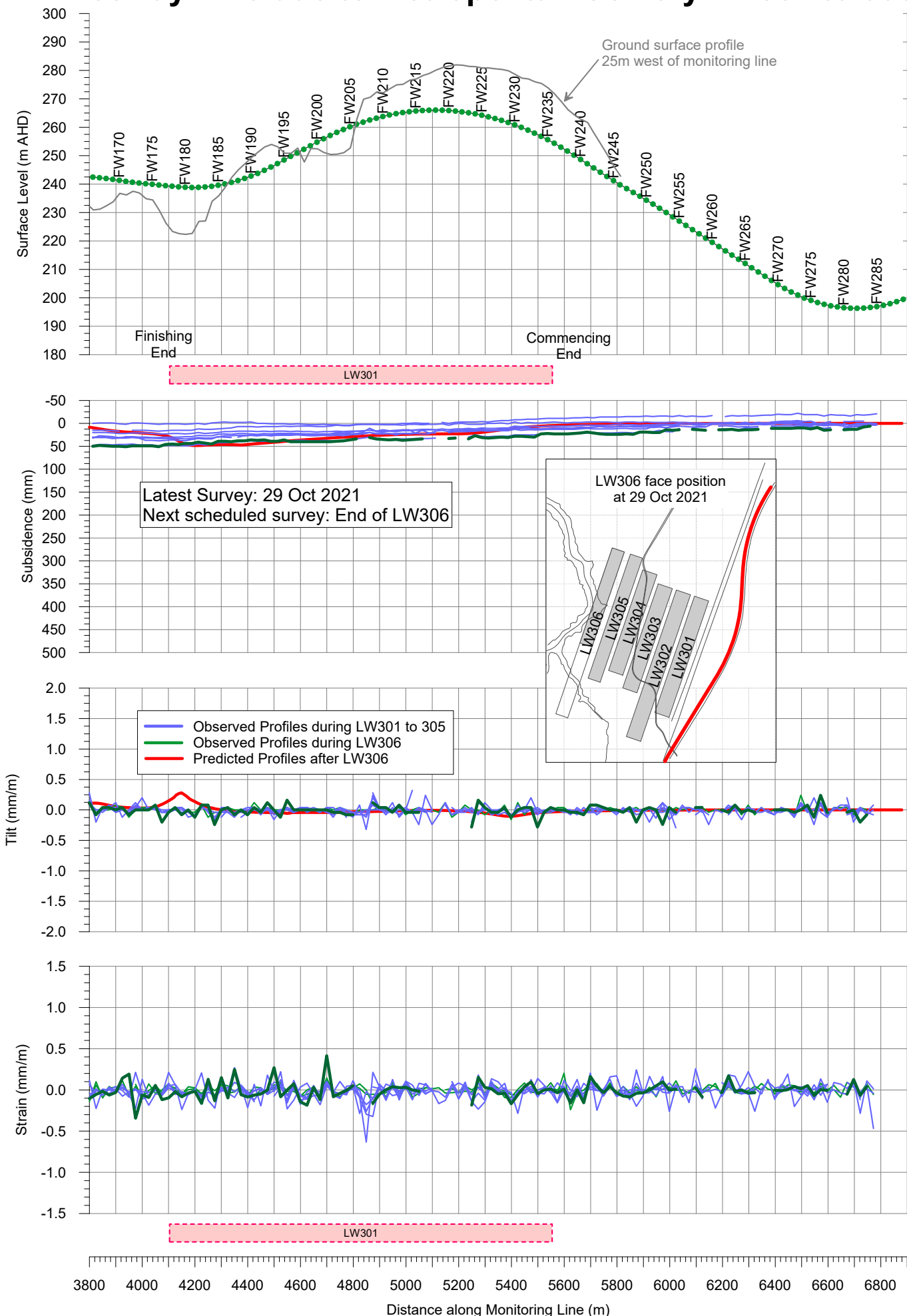

# Observed Total Subsidence at GNSS Monitoring Stations

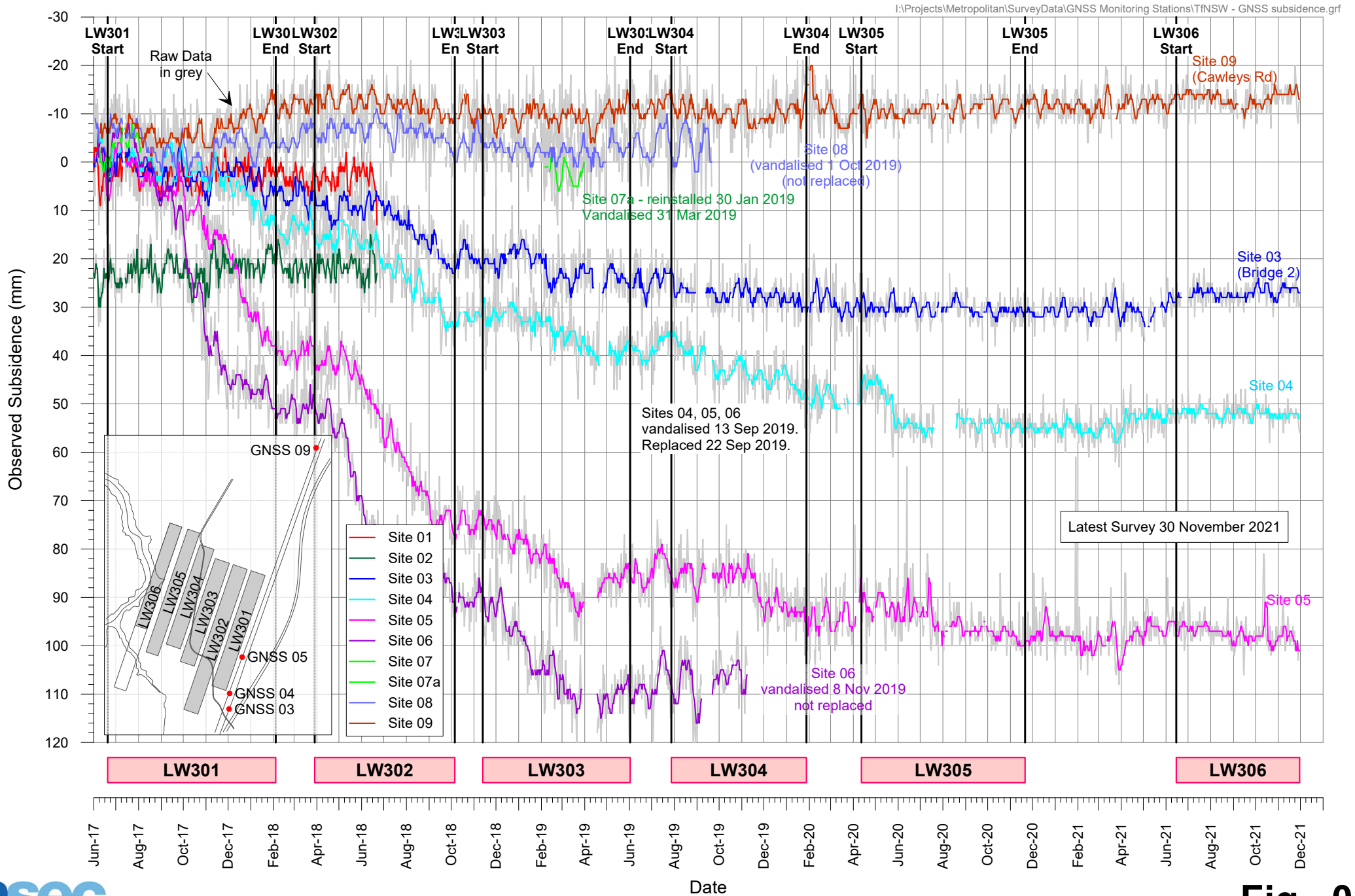

# GNSS Stations Total Horizontal Movement due to Longwall 301 to 306

## Site 09 - Cawleys Rd

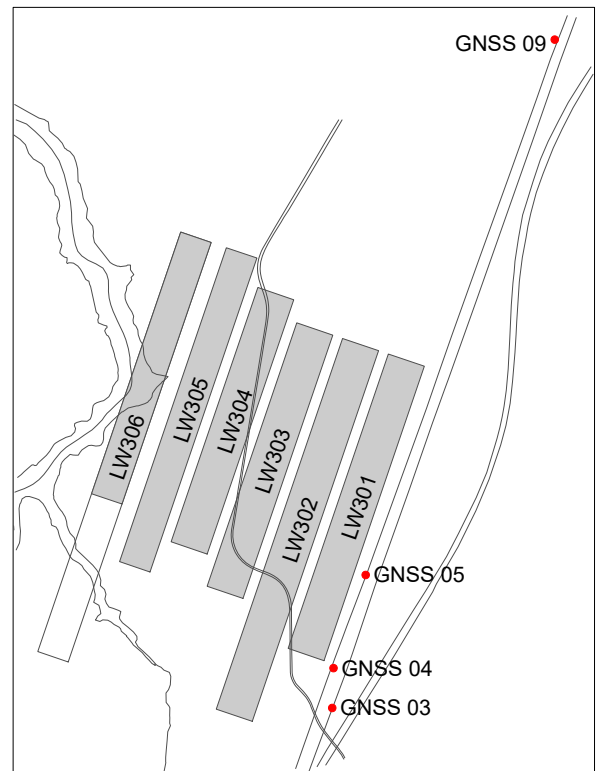
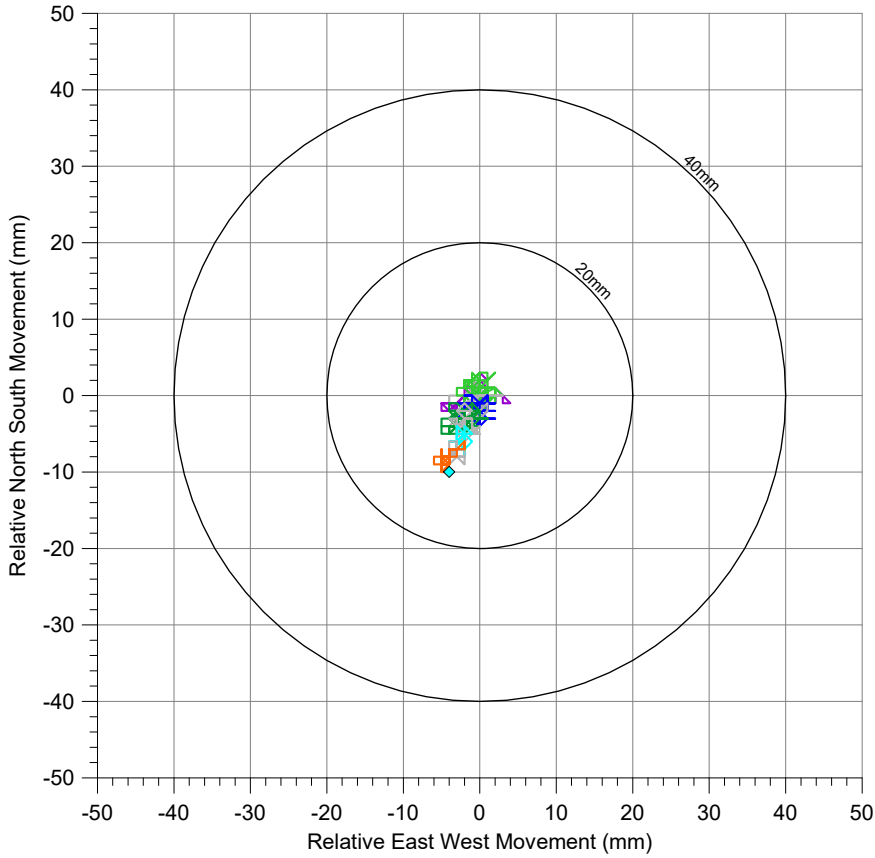

## Site 03 (Bridge 2)

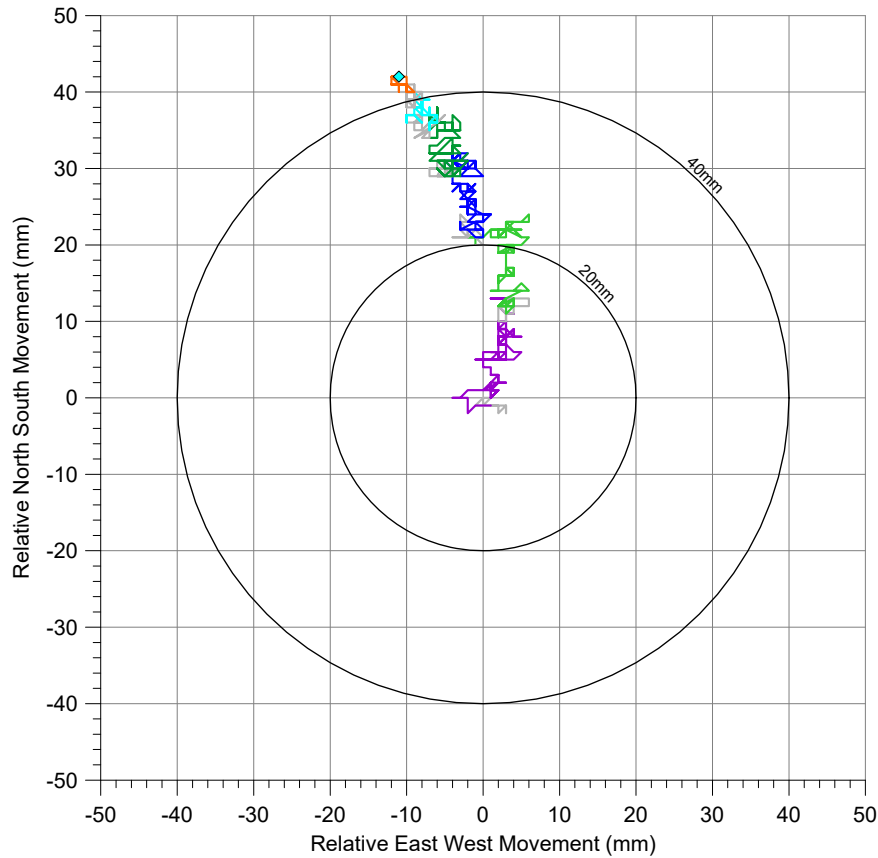

Latest Survey 30 November 2021

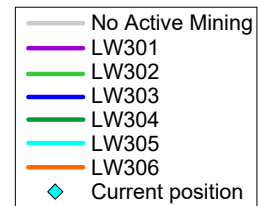

# GNSS Stations Total Horizontal Movement due to Longwall 301 to 306

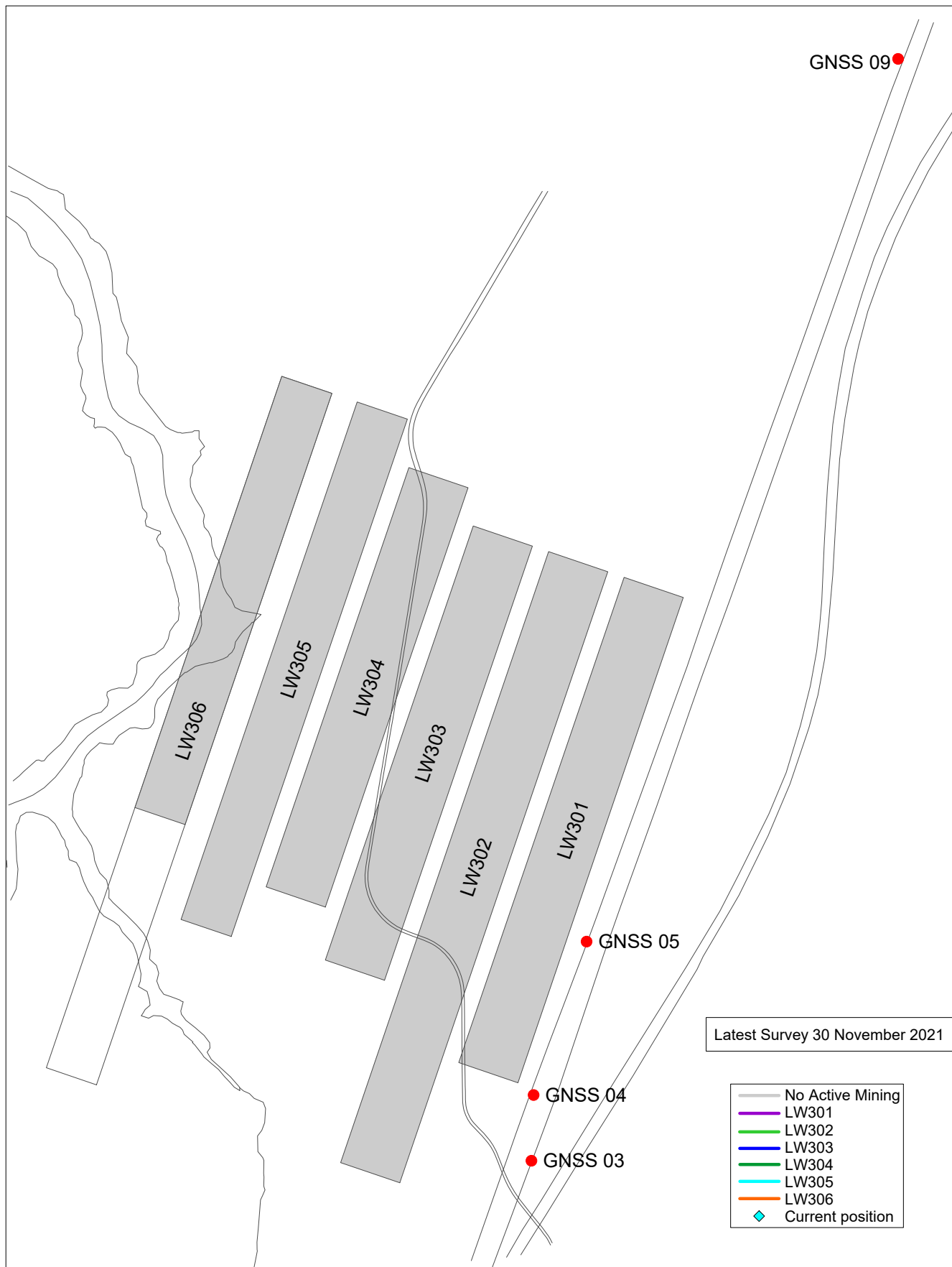

## Site 09 - Cawleys Rd

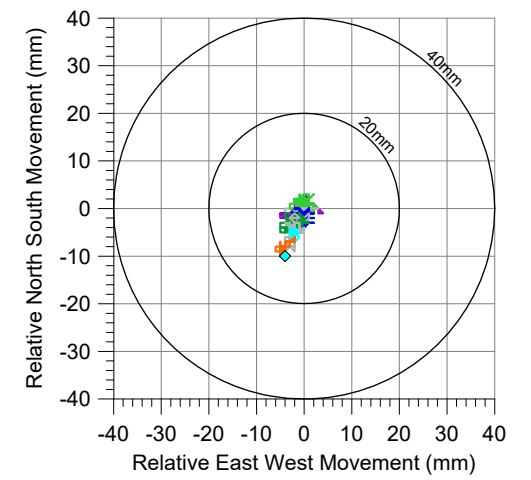

## Site 08 - Tower 108

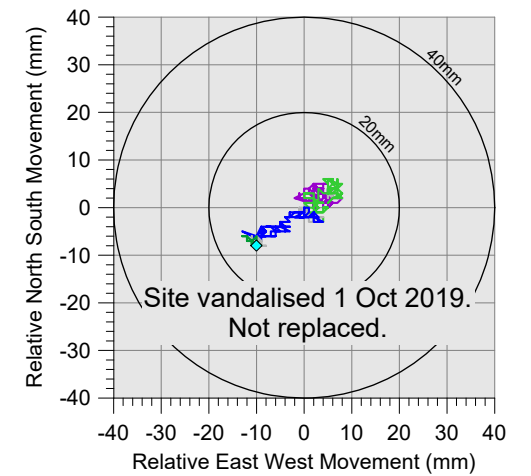

## Site 07a - Tower 107

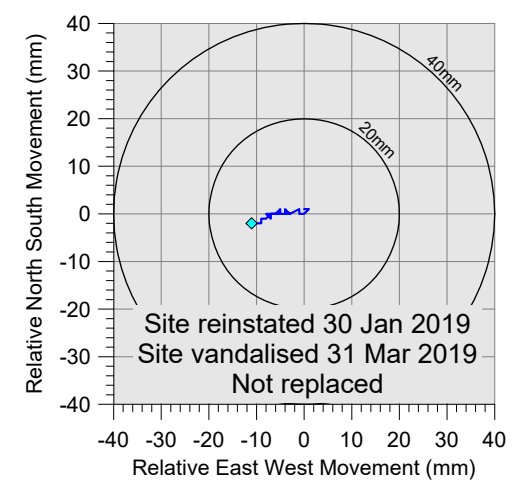

## Site 06 - Tower 106

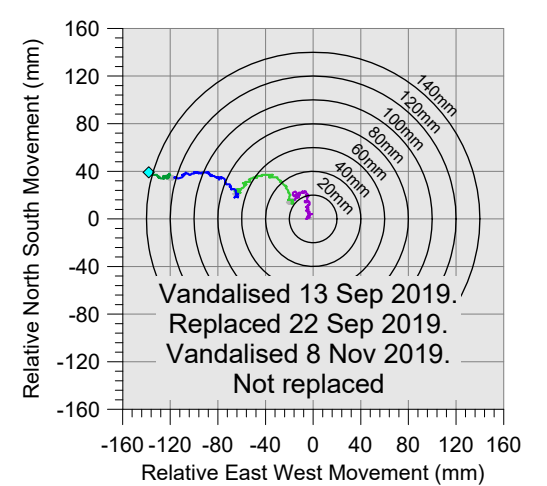

## Site 03 (Bridge 2)

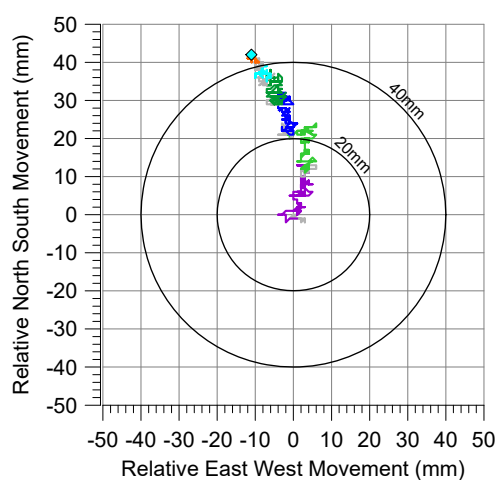

## Site 04 - Tower 104

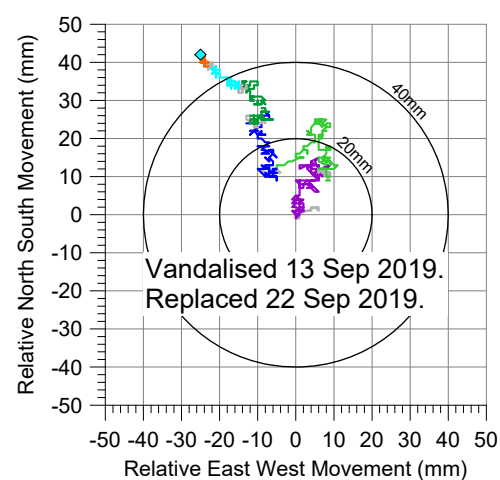

## Site 05 - Tower 105

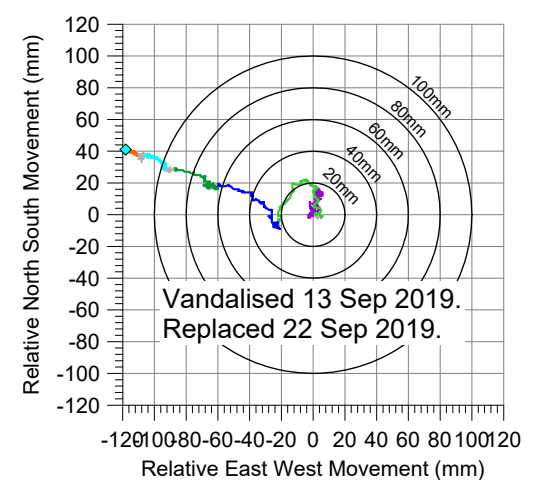

# Observed Opening and Closure between GNSS Monitoring Stations

I:\Projects\Metropolitan\SurveyData\GNSS Monitoring Stations\TfNSW - GNSS closure.grf

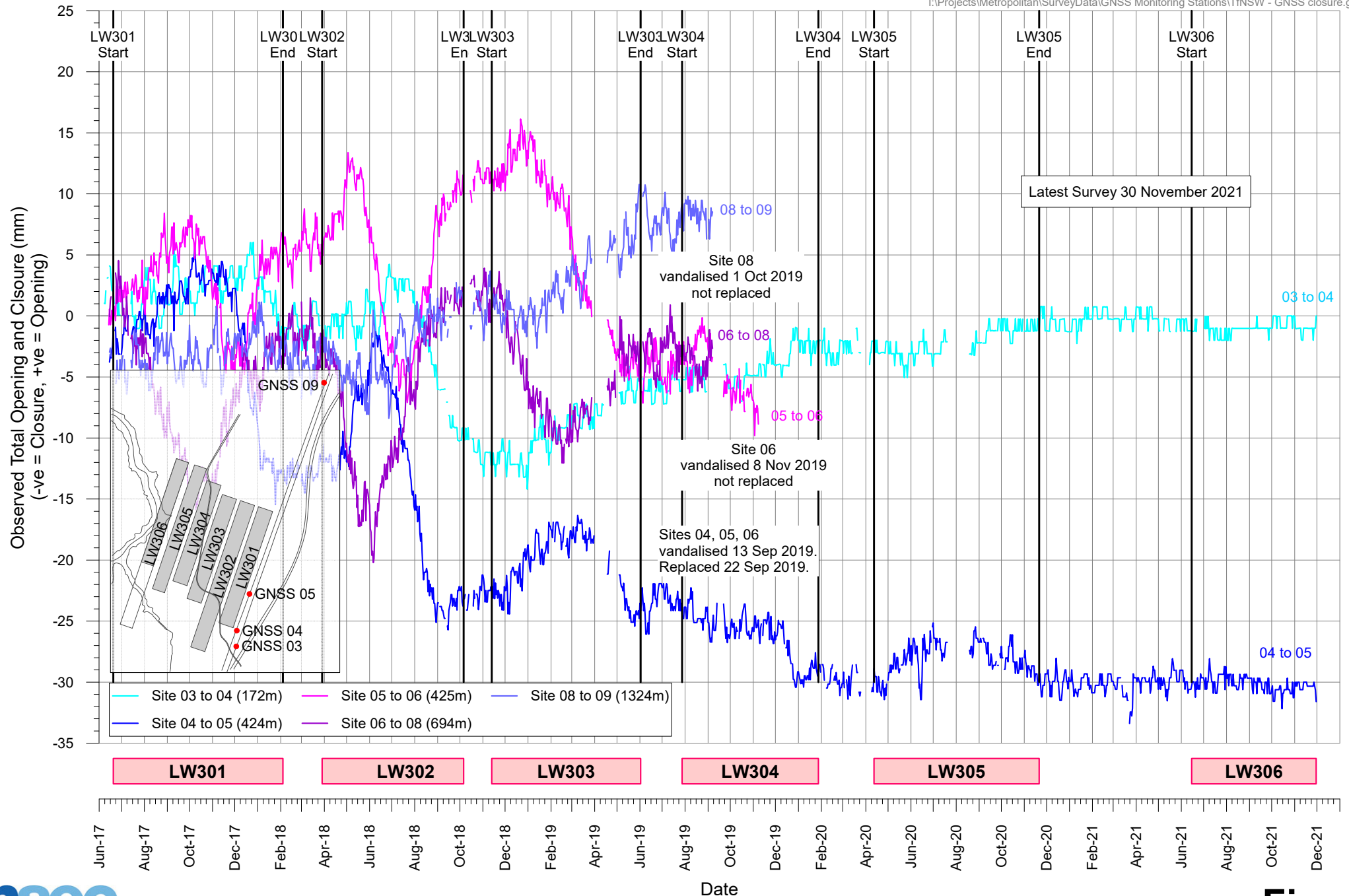



Suite 402, 13 Spring Street, Chatswood NSW 2067  
PO Box 302, Chatswood NSW 2057  
Tel +61 2 9413 3777  
www.minesubsidence.com



### METROPOLITAN COLLIERY LONGWALL 306 MONITORING TNSW - RMS BUILT FEATURES

DATE: 7 Dec 2021	SCALE: 1:12500	DRAWING No: MSEC1187-04	Rev No 06
---------------------	-------------------	----------------------------	--------------

**LEGEND**

- TNSW - RMS INFRASTRUCTURE- M1 PRINCES MOTORWAY
- BRIDGES
- CUTTINGS
- EMBANKMENTS
- CULVERTS
- GEOLOGICAL FAULTS AT SEAM LEVEL

**SURVEY DATE: 30-Nov-2021**

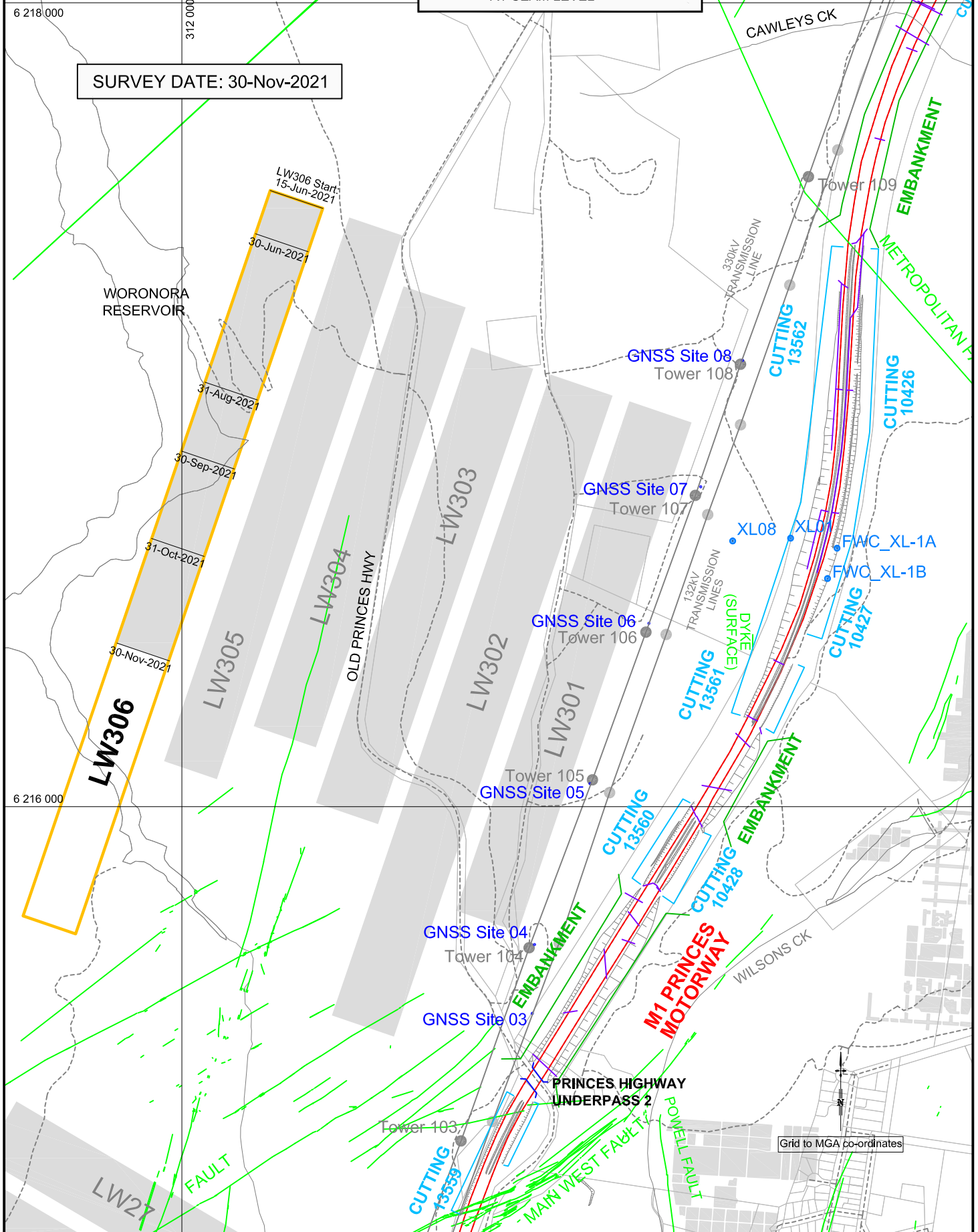

Grid to MGA co-ordinates

## APPENDIX 4

### GLOSSARY OF TERMS TFNSW AND DEFINITIONS

Metropolitan Coal – LW305-307 Built Features Management Plan – Roads and Maritime Services		
Revision No. BFMP_TFNSW-R01-D	ME-TSE-MNP-0088	
Document ID: Built Features Management Plan - TFNSW		

Some of the more common mining terms TfNSW used in the built features management plan are defined below:

- Angle of draw** The angle of inclination from the vertical of the line connecting the goaf edge to the limit of subsidence (which is usually taken as 20 millimetres [mm] of subsidence).
- Closure** The reduction in the horizontal distance between valley sides. The magnitude of closure, typically expressed in mm, is the greatest reduction in distance between any two points on opposing valley sides. The observed closure movement across a valley is the total movement resulting from various mechanisms, including conventional mining induced movements, valley closure movements, far-field effects, downhill movements and other possible strata mechanisms.
- Confidence Level** The likelihood that an observed value will be less than the stated value.
- Distortion (of a structure)** The change in dimension, shape or geometry of a structural element resulting in the development of stresses and strains in that element.
- Far-field movements** The measured horizontal movements at pegs that are located over solid unmined coal areas beyond the longwall panel edges. Far-field horizontal movements tend to be bodily movements towards the extracted goaf area and are accompanied by very low levels of strain.
- Horizontal displacement** The horizontal movement of a point on the surface of the ground as it settles above an extracted panel.
- Mid-Ordinate Deviation** Horizontal displacement measured across a monitoring line. Mid-ordinate deviation is a measure of horizontal shear deformation and can also be described by other parameters including: horizontal tilt; horizontal curvature; angular distortion; and shear index. Mid-ordinate deviation is illustrated in the following sketch:

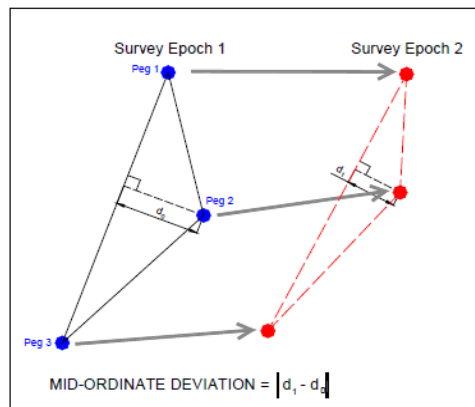

Metropolitan Coal – LW305-307 Built Features Management Plan – Roads and Maritime Services		
Revision No. BFMP_TFNSW-R01-D	ME-TSE-MNP-0088	
Document ID: Built Features Management Plan - TFNSW		

**Probability of Exceedance** The probability that an observed value will be greater than the stated value.

**Relative Movement**

Relative movement is the change in position between two or more surveyed points. Relative movement is normally measured along two or three axes ( $\delta X$ ,  $\delta Y$ ,  $\delta Z$ ) and the axes can be aligned in any convenient direction (e.g. along a monitoring line, aligned with a feature, aligned with north). (Also referred to as Differential Movement).

Relative movement of the **ground** at TFNSW Bridge 2 refers to movement of ground survey points located at the bridges supporting columns and blade walls relative to other such ground points.

Relative movement of the **structure** of TFNSW Bridge 2 refers to movement of a point on the bridge structure relative to other such points.

Relative Lateral and Longitudinal Horizontal Movements refer to relative horizontal movement across and along the alignment of two ground monitoring survey marks respectively. For the survey of bridges, the longitudinal direction adopted is the direction in which the bridge girders span (i.e. in the direction of traffic movement).

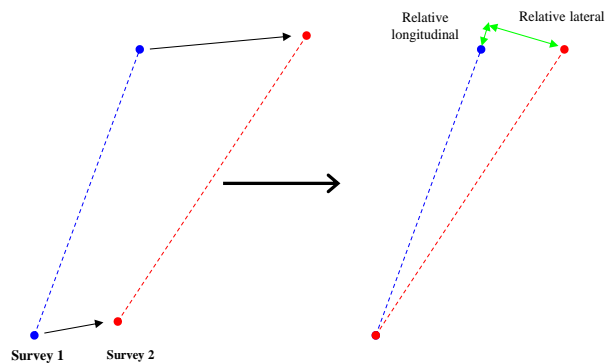

**Strain**

The change in the horizontal distance between two points divided by the original horizontal distance between the points. Strain is dimensionless and can be expressed as a decimal, a percentage or in parts per notation.

**Tensile Strains** occur where the distance between two points or survey pegs increases and **Compressive Strains** occur where the distance between two points decreases.

**Subsidence**

The vertical movement of a point on the ground surface as it settles above an extracted panel, but, 'subsidence of the ground' in some references can include both a vertical and horizontal movement component. Subsidence is usually expressed in units of mm. In this document subsidence relates only to vertical movement.

Metropolitan Coal – LW305-307 Built Features Management Plan – Roads and Maritime Services		
Revision No. BFMP_TFNSW-R01-D	ME-TSE-MNP-0088	
Document ID: Built Features Management Plan - TFNSW		

**Tilt** The change in the slope of the ground as a result of differential subsidence, and is calculated as the change in subsidence between two points divided by the horizontal distance between those points. Tilt is, therefore, the first derivative of the subsidence profile. Tilt is usually expressed in units of millimetres per metre (mm/m). A tilt of 1 mm/m is equivalent to a change in grade of 0.1 percent, or 1 in 1000.

**Upsidence** Upsidence results from the dilation or buckling of near surface strata at or near the base of a valley. The magnitude of upsidence, which is typically expressed in mm, is the difference between the observed subsidence profile within the valley and the conventional subsidence profile expected in flat terrain.

Metropolitan Coal – LW305-307 Built Features Management Plan – Roads and Maritime Services		
Revision No. BFMP_TFNSW-R01-D	ME-TSE-MNP-0088	
Document ID: Built Features Management Plan - TFNSW		

APPENDIX 5

METROPOLITAN COLLIERY LONGWALL MINING – LW 301-303 RISK ASSESSMENT AS  
APPLIED TO RMS ASSETS

Metropolitan Coal – LW305-307 Built Features Management Plan – Roads and Maritime Services		
Revision No. BFMP_TFNSW-R01-D		
Document ID: Built Features Management Plan - TFNSW		

Roads & Maritime Services

**Metropolitan Colliery Longwall  
Mining – LW301-303**

**Risk Assessment as Applied to RMS  
Assets**

250981/REP/001

Issue | 7 November 2016

This report takes into account the particular instructions and requirements of our client.

It is not intended for and should not be relied upon by any third party and no responsibility is undertaken to any third party.

Job number 250981-00

Arup  
Arup Pty Ltd ABN 18 000 966 165



**Arup**  
Level 17  
1 Nicholson Street  
East Melbourne VIC 3002  
Australia  
[www.arup.com](http://www.arup.com)

**ARUP**

# Document Verification

# ARUP

<b>Job title</b>		Metropolitan Colliery Longwall Mining – LW301-303		<b>Job number</b>		250981-00	
<b>Document title</b>		Risk Assessment as Applied to RMS Assets		<b>File reference</b>			
<b>Document ref</b>		250981/REP/001					
<b>Revision</b>	<b>Date</b>	<b>Filename</b>	20160902 RMS Report - Draft 1.docx				
Draft 1	02 Sep 2016	<b>Description</b>	First draft				
			Prepared by	Checked by	Approved by		
		Name	Jenny Li	Nigel Cann	Nigel Cann		
		Signature					
Draft 2	29 Sep 2016	<b>Filename</b>	20160929 RMS Report - Draft 2.docx				
		<b>Description</b>	Second draft incorporating feedback comments				
			Prepared by	Checked by	Approved by		
		Name	Jenny Li	Jenny Li	Nigel Cann		
		Signature					
Draft 3	20 Oct 2016	<b>Filename</b>	20161020 RMS Report - Draft 3.docx				
		<b>Description</b>	Third draft – includes assessment of Cawley Road Overpass				
			Prepared by	Checked by	Approved by		
		Name	Jenny Li	Jenny Li	Nigel Cann		
		Signature					
Issue	07 Nov 2016	<b>Filename</b>	20161107 RMS LW301-303 Report - ISSUE.docx				
		<b>Description</b>	Issue				
			Prepared by	Checked by	Approved by		
		Name	Jenny Li	Jenny Li	Nigel Cann		
		Signature					
<b>Issue Document Verification with Document</b>							<input checked="" type="checkbox"/>

## Contents

---

	Page
<b>1 Introduction</b>	<b>1</b>
<b>2 Description of Proposed Mining</b>	<b>1</b>
<b>3 RMS Assets Affected</b>	<b>3</b>
3.1 Predicted Ground Movements	3
3.2 Assessment of Ground Movement Impacts	5
<b>4 Risk Workshop</b>	<b>5</b>
<b>5 Results</b>	<b>6</b>
5.1 Carriageway	7
5.2 Culverts	7
5.3 Cuttings	7
5.4 Bridge and Overpass	8
<b>6 Conclusions</b>	<b>8</b>

## Appendices

### Appendix A

Risk Register

### Appendix B

Workshop Participants

### Appendix C

Workshop Agenda

### Appendix D

Risk Criteria

### Appendix E

Peabody Presentation

### Appendix F

MSEC Report

## 1 Introduction

---

Arup has been engaged by Roads & Maritime Services (RMS) to undertake a risk assessment with regards to the impacts on RMS assets arising from subsidence due to the mining of longwalls LW301-303 in the Metropolitan Mine which is owned by a subsidiary of Peabody Energy (Peabody).

Previous risk assessments were completed in 2009 and 2013 on the impacts of subsidence from LW20-22 and LW23-27 respectively. A history of the impacts of subsidence has been gained, along with knowledge about the performance of mitigation control measures applied and the reliability of the monitoring systems utilised.

As with the previous assessments, the concern of RMS is the possible impacts from the mining of LW301-303 on its surface assets with a specific emphasis on how the mining might result in financial loss to RMS, loss of functionality of the assets with regards to the road users (motorists and public) and possible life safety issues, should the mining adversely impact on any of the assets.

The process adopted by Arup follows closely the principles set out in AS/NZS ISO31000:2009 – Risk Management, and also the various standards of RMS, specifically those relating to the assessment of risks posed by subsidence mining.

Arup undertook an inspection of the assets followed by a facilitated workshop with relevant stakeholders to firstly identify the assets at risk and then ascertain the risks posed to those assets from the mining of LW301-303. This same workshop also considered various mitigation and control measures and determined the effectiveness of these in reducing risk levels.

The events and activities identified in the workshop will be addressed and managed in the Built Features Management Plan for LW301-303.

## 2 Description of Proposed Mining

---

Peabody, or Metropolitan Colliery (MC), proposes to extract longwalls LW301-303 as part of its ongoing underground coal mining operations within the Bulli Seam at the Metropolitan Mine. The mine is located in the Southern Coalfield of New South Wales. The overall layout of longwalls LW301-303 is shown in Figure 1.

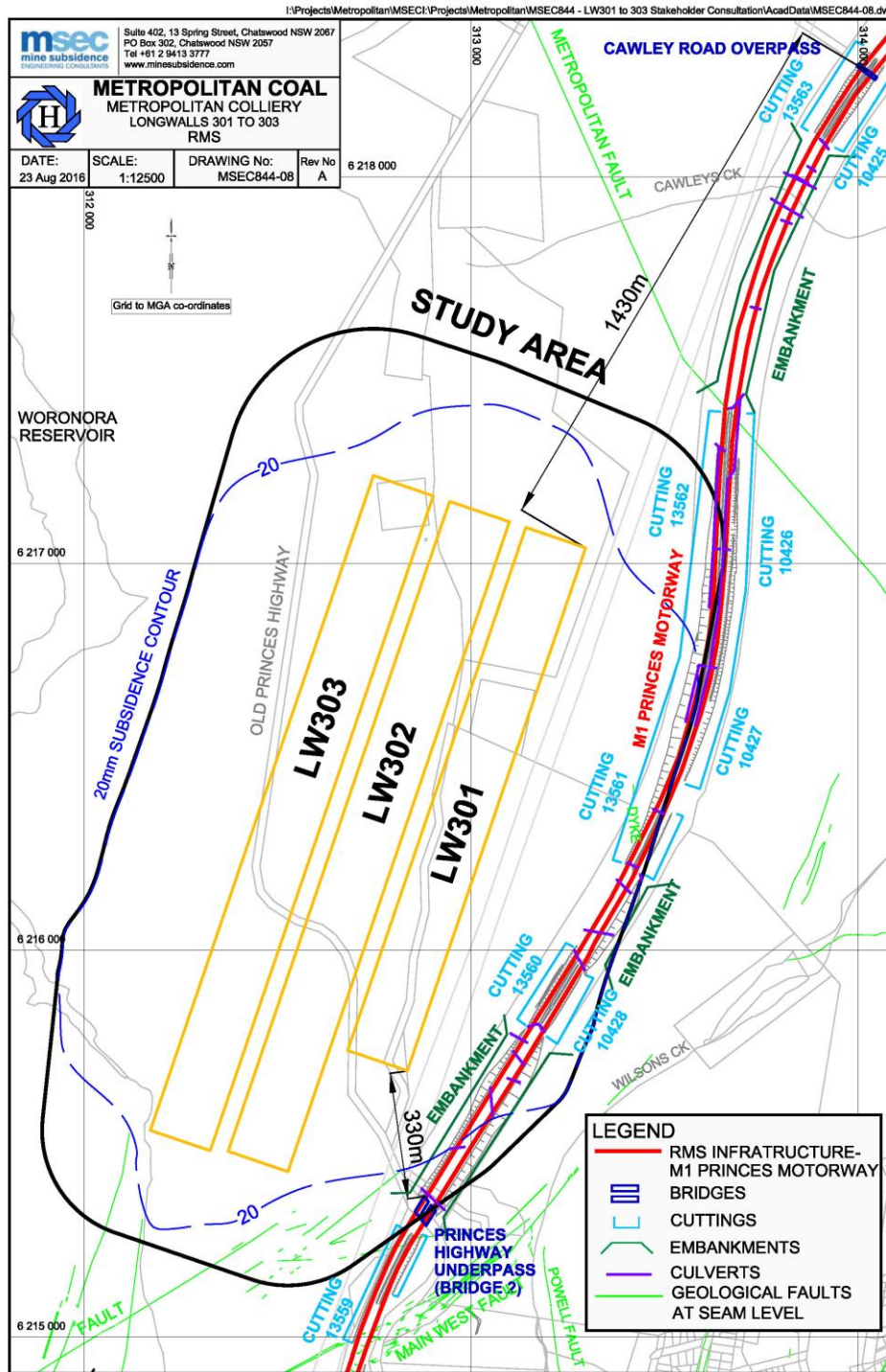

Figure 1: Layout of LW301-303

## 3 RMS Assets Affected

---

Figure 1 shows the extent of the proposed mining in relation to various RMS assets.

The RMS guidelines [Ref 1] define the zone of interest for infrastructure impacts as being five times the depth of cover. With a depth of cover of approximately 400m, the zone of interest extends some 2km from the longwalls.

The M1 Princes Motorway is located to the east of LW301-303. The distance of the M1 from LW301-303 varies from 210m near the finishing (southern) end of LW301 to 335m near the commencing (northern) end of LW301. There is also a series of cuttings and embankments up to a maximum height of approximately 20m along the M1.

There are two bridges (BN616/617) carrying the northbound and southbound traffic on the M1 Princes Motorway over the old Princes Highway and are located approximately 330m from LW301. The next nearest bridge is Cawley Road Overpass (BN615), which is located approximately 1.43km to the north east of LW303.

A series of culverts of varying diameters from 375mm to 1800mm cross the M1 Princes Motorway. A number of the culverts are asbestos cement pipes. In addition to the culverts, there are also a number of other drainage structures, such as kerbs, gutters, pits and drainage pipes. The largest culvert comprises two 1800mm pipes located to the north east of the longwalls at Cawley's Creek.

It should be noted the two large culverts and Cawley Road Overpass are located well outside the predicted 20mm subsidence contour.

### 3.1 Predicted Ground Movements

Mine Subsidence Engineering Consultants Pty Ltd (MSEC) presented their predictions of ground movements for RMS assets from the mining of LW301-303, and a broad assessment of impact on the assets in a report which is included as Appendix F.

#### 3.1.1 Movements Affecting the M1 Motorway

The following is a summary of the ground movement predictions for the M1 Motorway, as stated in the MSEC report in Appendix F:

- The maximum predicted conventional tilt and curvature are less than the expected limits of survey accuracy (i.e. 0.5mm/m for tilt and 0.01km<sup>-1</sup> for curvature).
- The M1 will potentially experience far-field horizontal movements of up to 115mm, based on a 95% confidence level, from a database of observed far-field horizontal movements in the Southern Coalfield.
- Similarly from the Southern Coalfields survey database, the 95% confidence intervals for the maximum total strains that the individual survey bays above

solid coal (100-250m) experienced at any time during mining are 0.4mm/m tensile and compressive.

- Predicted valley closure across the culvert at the location of the M1 is less than 20mm.
- Valley closure is not expected to occur in the cuttings along the M1, however, minor closure movements could be observed due to potential horizontal movements.

### 3.1.2 Movements Affecting Bridges

Because of the critical function of Bridge 2, and as for other bridges, RMS requires assessment of the effects of ground movements of magnitudes that have 1 in 100 and 1 in 2000 probability of exceedance due to mining. This is consistent with the limit state approach to bridge design (and checking) embodied in the Bridge Design Standard (AS5100). MSEC has therefore produced values for incremental relative opening, closing and mid-ordinate deviation at various probabilities, including 1 in 100 and 1 in 2000, to be applied to the bridge elements in both the longitudinal and transverse directions of the bridge for the assessment of potential effects on the bridge structure. Refer to the MSEC report in Appendix F for the relative movement values at various probabilities of exceedance.

The following is a summary of the ground movement predictions for Bridge 2, derived from the MSEC report in Appendix F.

At Bridge 2, a distance of approximately 330m from the closest point of the longwalls, the predicted subsidence parameters are less than survey tolerance, which is typically 20mm for subsidence, 0.5mm/m for tilt and  $0.01\text{km}^{-1}$  for curvature. The absolute horizontal movements measured at distances greater than 330m are in the order of 95mm based on the 95% confidence level.

Differential horizontal movements, which are most significant for the bridge structures, are difficult to predict since the potential values of relative movement are typically very small. For Bridge 2, there is the added complication that the spacing of bridge support elements varies from 5-18m as compared to the commonly used spacing between survey points along monitoring lines of approximately 20m.

Cawley Road Overpass is located at a distance of 1.43km from Longwall 301 at its nearest point. At this distance, observed far-field movements from the Southern Coalfields database are close to nominal survey tolerance and observed differential horizontal movement data is predominantly within survey tolerance.

However, as for Bridge 2, Cawley Road Overpass needs to be assessed for low probability differential ground movements and MSEC has provided values for incremental relative opening, closing and mid-ordinate deviation at various probabilities of exceedance, including 1 in 100 and 1 in 2000, to be applied to the bridge elements for the assessment of potential effects.

## 3.2 Assessment of Ground Movement Impacts

### 3.2.1 Assessment of Impacts on M1 Motorway

The MSEC report in Appendix F included the following broad assessment of impacts on the M1 Motorway.

*The predicted conventional vertical subsidence for the M1 resulting from the extraction of LW301-303 is very small and the predicted tilts and curvatures are less than the expected limits of survey tolerance (i.e. 0.5mm/m for tilt and  $0.01\text{km}^{-1}$  for curvature). Adverse impacts to the M1, including the road pavement, slopes, culverts, barriers and furniture, resulting from conventional subsidence movements is considered unlikely.*

MSEC recommended that monitoring and management strategies are developed to manage the potential impacts on the M1, which would allow for the motorway to be maintained in a safe and serviceable condition.

### 3.2.2 Assessment of Bridges

A detailed quantitative assessment of the potential impacts of ground movements from Longwalls 301 to 303 on Bridge 2 (BN616/617) has been undertaken by the RMS Technical Committee. The Committee commissioned the bridge specialist on the committee (Cardno) to investigate and report on the potential effects on the bridge of the 1 in 100 and 1 in 2000 exceedance probability for differential ground movements. The report on that investigation was issued to the committee in May 2015. As ground movements of varying probability of exceedance were investigated, this could be considered to be a detailed quantitative risk assessment.

In summary, the assessment found that the 1 in 100 probability differential ground movements could be tolerated by the structure with only relatively minor cracking as the worst consequence. It found that the 1 in 2000 probability differential ground movements could produce unacceptable effects including structural failure at some locations, if they occurred at disadvantageous locations. In this unlikely event, mining of the longwall may have to be terminated earlier than planned.

A similar detailed quantitative assessment of the effects of low probability differential ground movements on the Cawley Road Overpass was carried out. It found that the Cawley Road Overpass can tolerate the predicted ground movements up to the 1 in 2000 probability values.

## 4 Risk Workshop

---

On 25 August 2016, a risk workshop was convened at the RMS Offices in Wollongong. The purpose of this workshop was to assess the risks posed to the assets of the RMS from this proposed longwall mining operation. A list of the participants at the workshop is included in Appendix B. The agenda is attached in Appendix C.

Peabody Energy provided an overview of the LW301-303 extraction area, an update on the mine activities and the current location and an update on the subsidence performance to date and inspections of the RMS assets (refer to Appendix E).

This workshop was qualitative and used the RMS look up sheets for assessing both frequency and consequence. These sheets have been adopted as the standard by the RMS when assessing the risk posed to their assets from subsidence mining. The look up sheets for assessing frequency, consequence, and the risk matrix are included in Appendix D.

The assets considered in the risk assessment included:

- Bridge 2 – BN616 (southbound) and BN617 (northbound);
- Cawley Road Overpass – BN615;
- Carriageway;
- Culverts;
- Kerb;
- Cuttings;
- Embankments;
- Furniture;
- Drains;
- Variable Message Sign (VMS); and
- Other structures such as power lines (which are not RMS assets but failure may affect RMS assets).

The workshop used the risk register from the previous studies (LW20-22 and LW23-27) as the basis of discussion and reviewed each of the risks. For new items, a check-list of Assets and Fault/Failure modes was used to trigger thoughts and discussion. This information was recorded in the risk register, attached in Appendix A.

## 5 Results

---

A total of 19 risk events were identified during the workshop, of which 11 were not considered to present a credible risk (the level of possible impacts was not measurable). Additional mitigations were discussed for 11 risk events.

The risk profile before and after the application of additional mitigation measures is presented in Table 1. It should be noted that all the additional mitigations suggested involve monitoring which does not change the risk ratings of the event.

Table 1: Risk Profile Before and After Implementation of Additional Mitigations

Receptor	Infrastructure				Functionality				Safety			
Risk Level	E	H	M	L	E	H	M	L	E	H	M	L
Base Risk Score	0	1	2	3	0	2	0	4	0	0	1	5
Final Risk Score	0	1	2	3	0	2	0	4	0	0	1	5

## 5.1 Carriageway

Generally tensile strains are expected on the carriageway due to mining of LW301-303. Hence tensile cracking would be expected as a result of normal subsidence movements. The level of predicted strain is relatively low (0.7mm/m for a 99% confidence level). Hence small tensile cracks can be expected. Minor humping is possible if shear occurs along some geological structure. Hence, in terms of the carriageway, there could be deformations such as minor cracks and humps due to the mining of LW301-303.

Visual inspections at the end of each panel would be appropriate to check for any cracks or deformations caused by the mining activities. RMS also performs drive-through checks during mining. A base line inspection needs to be recorded prior to commencement of mining.

The workshop group discussed that if possible, the planned resurfacing of the carriageway by RMS should be delayed until after LW303 has been mined (planned to be completed by quarter 1, 2019). This can remediate the road for any damage caused by the mining activities, as well as general road use wear and tear. In the interim crack sealing could be carried out where tension cracks occur.

## 5.2 Culverts

With valley closure movements less than 20mm anticipated, there are unlikely to be anything more than minor impacts on the culverts.

For the culverts a pre-mining condition assessment using CCTV should be completed and any further inspections should be performed as per the Monitoring Plan.

## 5.3 Cuttings

Stabilisation of the cuttings has recently been completed, and the post stabilisation risk rating of these cuttings is underway. It is anticipated that the Assessed Risk level (ARL) of the cuttings will be no worse than ARL3. It is unlikely that there will be any change in the risk ratings due to mining due to the low level of mining related movements anticipated.

For the cuttings, a survey is proposed at the end of completion of each panel. Monitoring of the transmission lines will also provide early indications for the cuttings within the 20mm subsidence contour. If the measurements exceed predicted levels, this may trigger a survey to be completed along the cuttings.

The regular RMS maintenance inspections are to include monitoring of rock fall.

## 5.4 Bridge and Overpass

Bridges BN616 and BN617 have been setup to allow for monitoring of differential movements between key points on the structures. The monitoring provisions include installation of survey targets fixed at key points and FBG sensor cable to measure relative movement of key points at the tops of piers and abutments. The monitoring systems aim to detect distortion of the bridges which can then be assessed by Cardno to determine the effects on the structure.

The monitoring strategy for the Cawley Road Overpass (BN615) includes only the installation of survey targets fixed at key points. This aim to detect distortion of the bridges which can then be assessed by Cardno to determine the effects on the structure. If significant differential movements are detected, increase frequency of monitoring to understand the trend of movement.

The transmission lines and Princes Hwy are also monitored by survey and this data can be used to predict potential impacts at the bridges. If significant relative movements are detected, then the frequency of monitoring at bridges should be increased to understand the trend of movement.

## 6 Conclusions

---

A risk assessment workshop has been completed to understand the risks to RMS assets from the mining of longwalls LW301-303. The events and activities identified in the workshop will be addressed and managed in the Built Features Management Plan for LW301-303.

It is recommended that the existing monitoring of the assets is to continue and be adaptive to unexpected subsidence changes.

## Appendix A

### Risk Register

ID	ASSET	FAILURE TYPE	EVENT	Infra			Function			Safety			COMMENT	ADDITIONAL MITIGATION	Infra			Function			Safety			COMMENT			
				F	C	R	F	C	R	F	C	R			F	C	R	F	C	R	F	C	R		F	C	R
1	Carriageway	Cracking in the transverse direction	Build up of tensile stresses in the carriageway adjacent to LW301 causing cracks in the transverse direction.	D	1	L	D	1	L	D	1	L	Pavement cracks in the transverse direction (due to longitudinal strains) would not be extensive. Strains are expected to be tensile within the 20mm subsidence contour but would be of low order - approximately 0.4mm/m (95% confidence level). It is likely that multiple cracks will form that can be resolved by crack sealing. Extensive zones of compressive strains are not anticipated and with compressive stains of approximately 0.4mm/m (95% confidence level), no discernable impacts are anticipated.	End of Panel check visual inspection would be appropriate. Also continue RMS drive through check during mining. Base Line inspection needs to be recorded.	D	1	L	D	1	L	D	1	L				
2		Cracking in longitudinal direction	Build up of tensile stresses in the carriageway causing cracks in the longitudinal direction.	D	1	L	D	1	L	D	1	L	Pavement cracks in the longitudinal direction (due to transverse strains) would not be extensive due to the limited width of pavement in the transverse direction. Strains are expected to be tensile within the 20mm subsidence contour but would be of low order - approximately 0.4mm/m (95% confidence level). Over a 12m carriage way width, the maximum single crack would be <5mm. More likely, multiple cracks of smaller widths will form that can be resolved by crack sealing. For compressive strains, no impacts are anticipated due to the 12m carriageway width.	End of Panel check visual inspection would be appropriate. Also continue RMS drive through check during mining. Base Line inspection needs to be recorded.	D	1	L	D	1	L	D	1	L				
3		Stepping	Rapid pavement failure, leading to hump or step										Not credible for the proposed longwalls.														
4		Deformations through geological structures and cut fill interfaces.	Structures to south of area at seam level. Dyke at Cutting 13561.	E	2	L	E	2	L	E	2	L	Small deformations expected (humping and cracking). Can be detected through drive throughs and corrected as required.	End of Panel check visual inspection would be appropriate. Also continue RMS drive through check during mining. Base Line inspection needs to be recorded.	E	2	L	E	2	L	E	2	L				Planned resurfacing by RMS should be delayed till after LW303 - Q1 2019 if condition allows.

5	Culvert	Culvert cracking due to mining movements	Culvert joints open, culvert damage (minor cracking)	E	3	M	E	1	L	E	1	L	<p>If there is shearing movement, there should not be any issues. Probability of fault movement is very low as the mining is planned to not cause movement in the faults.</p> <p>Most culverts are asbestos cement.</p> <p>Pipes &lt;500mm diameter, stresses would not cause a problem unless the pipes are already frail.</p>	<p>Premining condition assessment of culverts (using CCTV). Further inspections as per Monitoring Plan.</p>	E	3	M	E	1	L	E	1	L		
6		Lose culvert grading	Ponding.										Not credible for the proposed longwalls.												
7	Kerb	Kerb/gutter cracking / buckling	Included as part of Pavement Assessment.																						
8	Cuttings	Excessive ground movement causing localised instability	Material falling onto the road. Remediation works already completed include grooming of slopes, shot-creting, fencing, rock netting and benching already completed. These treated slopes are in cuttings closest to LW301-303 and were re-rated by RMS in 10/16 as ARL4. The predicted movements are relatively minor - <50mm for subsidence and <20mm for valley closure, and these movements will not change the risk ratings for these slopes.										<p>Tensile cracking at the top of the cuttings could occur and this could cause water infiltration. However, the dyke is more likely to weather. Cuttings at Cawleys Road Overpass (CRO) – These cuttings are rated ARL2 (high risk), but are located ~1300m from the start line of LW301. Also, the Metropolitan Fault lies between LW301 and CRO, thereby forming a barrier to mining related movements at the cuttings. While movements of concern are not expected, these cuttings will be included in the monitoring proposed for CRO. Cuttings (2) south of LW301 – The nearer cutting rated ARL3 is ~870m from the LW301 finish line, and the other rated ARL2 is ~1120m from the LW301 finish line. While no discernable movements are expected at these cuttings from the mining of LW301-303, the cuttings will be monitored in accordance with Table 9 of the BFMP.</p>	<p>Survey monitoring at the completion of mining of each longwall. Monitoring of the transmission lines will provide early indications for the cuttings within the 20mm subsidence contour. If the measurements exceed predicted levels, this may trigger a survey to be completed along the cuttings. Maintenance inspections to include monitoring of rock fall. Inspection will be carried out during the daytime network inspection which occurs at a frequency of once per week with the direction alternating.</p>											Refer attached memo.
9	Embankments	Excessive ground movement leading to localised slip failure	Cracks, water, instability.										These are flexible earth structures. Any issues are hypothetical. Not credible for the proposed longwalls.												
10	Furniture		Damage and serviceability issues.										Not credible for the proposed longwalls.												
11	Drains (above cuttings)		Damage to drains.										Not credible for the proposed longwalls.												
12	VMS	Excessive ground movement	Damage to the VMS.										Not credible for the proposed longwalls.												

13	Power lines (not an RMS asset) but may affect RMS assets	Tower / cable failure	Electrical hazard.																																					
----	--	-----------------------	--------------------	--	--	--	--	--	--	--	--	--	--	--	--	--	--	--	--	--	--	--	--	--	--	--	--	--	--	--	--	--	--	--	--	--	--	--	--	--



**NOTE:**

RMS guidelines state a coverage zone of 5 times depth of mine (~2km).

All mitigation measures, regardless of the cell in which they are recorded, are deemed to apply to all risk events. Furthermore, control and mitigation measures listed in the report are also deemed to apply to all risk events in the risk register.

Memorandum

To	Dick Lee Shoy - Chair Technical Committee	Page	1
CC	Technical Committee		
Subject	LW301 to 303: Revised risk ratings for cuttings		
From	Henk Buys		
File/Ref No.	60342368-1.3	Date	28-Oct-2016

**1 Introduction**

A risk assessment workshop was held on 25-08-2016 to satisfy the requirements for the BFMP-RMS for extraction of Metropolitan coal’s longwalls LW701 to LW703. Risks in relation to stability of the existing cuttings along the M1 Princes Motorway in the vicinity of these longwalls were considered at the workshop. The cuttings are listed in MSEC letter report dated 24 August 2016 titled ‘Metropolitan Colliery – Proposed Longwalls 301 to 303 - Subsidence Predictions and Impact Assessments for the Roads and Maritime Services Infrastructure’. At the time the risk ranking for these cuttings was ARL2 in accordance with the RMS Guide to Slope Risk Analysis. These cuttings have recently been stabilised and subsequent to the workshop the post stabilisation risk rankings for the cuttings were completed. The updated risk rankings are provided in the table below:

**Table 1: Updated risk rankings for cuttings**

Cutting	Updated risk ranking	Comment
10425	ARL2	Not stabilised – At Cawleys Road overpass
10426	ARL4	Stabilised
10427	ARL4	Stabilised
10428	ARL4	Stabilised
10430	ARL3	Not stabilised – Approx 870m south of LW301
13557	ARL2	Not stabilised – Approx 1,120m south of LW301
13560	ARL4	Stabilised
13561	ARL4	Stabilised
13562	ARL4	Stabilised
13563	ARL2	Not stabilised – At Cawleys Road overpass

**2 Discussion**

**2.1 Stabilised cuttings (10426, 10427, 10428, 13560, 13561, 13562)**

Subsidence of less than 50mm is anticipated at the stabilised cuttings. This together with the substantial stabilisation measures carried out at these cuttings, no observable changes are anticipated at these cuttings. These cuttings will be inspected in accordance with Table 9 of the BFMP.

## **2.2 Cuttings at Cawleys Road overpass (10425, 13563)**

These cuttings are approximately 1300m from the LW301 start line. In addition, the Metropolitan Fault between LW301 and Cawleys road overpass forms a barrier to mining related movement at the cuttings. Hence no discernible movement is anticipated at these cuttings. However, due to the ARL2 risk ranking of these cuttings, visual inspections of these cuttings will be triggered by transmission line survey movements and absolute 3D movements as for Cawleys Road overpass. If these triggers are exceeded, visual inspections of the cuttings will be carried out to assess any change in their condition.

## **2.3 Cuttings south of LW301 (10430, 13557)**

Cutting 10430 has an ARL3 ranking and is some 870m from the LW301 finish line. No change in risk ranking for this cutting is anticipated.

Cutting 13557 has an ARL2 ranking, however it is some 1120m from the LW301 finish line. This cutting is unlikely to undergo discernible movements as a result of mining.

Whilst no changes in risk ranking of these cuttings are anticipated, these cuttings will be monitored in accordance with Table 9 of the BFMP.

Henk Buys  
Technical Director  
henk.buys@aecom.com

Mobile: +61 0448 997 500  
Direct Dial: +61 2 8934 0127

## **Appendix B**

### **Workshop Participants**

# ROADS & MARITIME SERVICES

## RISK ASSESSMENT - SUBSIDENCE IMPACTS ON RMS ASSETS

ATTENDANCE SHEET – 25 August 2016



Transport  
Roads & Maritime  
Services

Name	Position	Organisation
Nigel Cann	Facilitator - Risk Engineer	ARUP
Henk Bays	Geotech Engineer	AECOM.
AARON HAGENBACH	ENVIRONMENTAL ENGINEER	RESOURCE STRATEGIES.
DICK LEE SHOH	CHAIRMAN-TECHNICAL COMMITTEE	RMS
Cyril Ganerathne	Pavement Planner	RMS
Richard Woods	BRIDGE ENGINEER	CARDNO
Matthew Branton	Monitoring Engineer	Monitor Optics
PETER DEBONO	MINE SUBSIDENCE ENGINEER	MSEC
JON DELOTTARDI	TECHNICAL SERVICES MANAGER	PEABODY
Dony Castro	RM Bridge Maintenance Planner	RMS



## Appendix C

### Workshop Agenda

## Meeting with Roads & Maritime Services [Technical Committee]

LW301-303 Extraction Plan – Built Features Management Plan  
M1 Princes Motorway

**25 August 2016 – 10am to 3pm**  
**Wollongong RMS Office - Level 4 Conference Room**

---

# Agenda

**Purpose of meeting:**

- To discuss the subsidence predictions relevant to LW301-303 prepared by MSEC in their letter report dated 11 July 2016.
- Assess the risks relevant to LW301-303 for the Extraction Plan in accordance with the DP&E and DRE Draft *Guidelines for the Preparation of Extraction Plans*\*.
- Review existing controls, procedures and programs and update if required for the LW301-303 BFMP.

Item	Detail	Who	Time:
1.	Update on mine activities and current location	Peabody	10am
2.	Short overview of the LW301-303 extraction area		
3.	Subsidence predictions for LW301-303	MSEC	10:15
4.	Update on subsidence performance to date and inspections re: RMS assets (M1 Princes Motorway)	MSEC/Peabody	10:30
5.	Discussion on specific RMS assets including: <ul style="list-style-type: none"> <li>• Pavement</li> <li>• Bridges (Bridge 2; Cawley Road Overpass)</li> <li>• Cuttings/Embankments</li> <li>• Drains/Culverts</li> <li>• High Accuracy Fibre Optic Monitoring System</li> <li>• Conventional Survey/Visual Inspections</li> <li>• Management Measures</li> <li>• Contingency Measures</li> </ul>	Peabody/RMS/MSEC	10:45
6.	Risk assess any changes that may have bearing on the performance of the assets. Review existing controls, procedures and programs in existing BFMP (M1 Princes Motorway) for continued suitability and feasibility and update if required.	Peabody/RMS	12:30
7.	Next Steps <ul style="list-style-type: none"> <li>• Draft LW301-303 BFMP – for comment</li> </ul>	Peabody	2:30-3pm
		TOTAL	4-5 hrs

\*The Draft *Guidelines for the Preparation of Extraction Plans* require the BFMPs to include:

- the results of risk assessment conducted by a competent person in accordance with relevant standards and guidelines;
- description of the investigation and analysis methods used in determining the risk control measures and procedures, carried out by a competent person;
- description of all risk control measures and procedures, including a statement of the feasibility to manage identified risks; and
- a proposed program for implementation of the proposed risk control measures and procedures.

## **Appendix D**

### **Risk Criteria**

# ROADS & MARITIME SERVICES

## RISK ASSESSMENT - SUBSIDENCE IMPACTS ON RMS ASSETS

### FREQUENCY



Transport  
Roads & Maritime  
Services

Level	Descriptor	Alt. Description	Description	Chance %	Frequency
O	<b>Absolutely Certain</b>	Definite	This event will occur / known to occur now - Will occur several (many) times each year and many times (constantly) during this project	99.99	Several times each year
A	<b>Almost Certain</b>	Frequent	This event is expected to occur in most circumstances - Expected to occur more than once during the duration of this project	95	1 / year
B	<b>Likely</b>	Probable	This event will probably occur in most circumstances - Expected to occur once during the duration of the project	10	at least 1 / 10 years
C	<b>Possible</b>	Occasional	This event might (should) occur at some time - Not likely to occur in life of project, but it is possible.	1	at least 1 / 100 years
D	<b>Unlikely</b>	Remote	This event could occur at some time - Unlikely (very) to occur in life of project	0.1	at least 1 / 1,000 years
E	<b>Rare</b>	Very Unlikely	This event may occur in exceptional circumstances - Examples of this have occurred historically, but it is not anticipated for this project	0.01	at least 1 / 10,000 years
F	<b>Hypothetical</b>	Barely credible	Theoretically possible but never occurred to date (anywhere in the world) - Often applied to natural events	1.00E-03	every Million years

# ROADS & MARITIME SERVICES

## RISK ASSESSMENT - SUBSIDENCE IMPACTS ON RMS ASSETS

### CONSEQUENCES



Transport  
Roads & Maritime  
Services

Level	Descriptor	Infrastructure			Amenity			Safety / Societal Cost
		Pavement etc	Bridges	Cost	Access	Speed	Political	
1	<b>Insignificant</b>	Minor damage	Minor repairable damage	< \$50 k	Some loss in condition	No traffic effect	No political impact	No injuries or health effects
2	<b>Minor</b>	Noticeable damage	Damage that will deteriorate if not repaired quickly	< \$100 k	One lane closed for < half day; One planned lane closure < 1 day	Speed reduction for < 1 month - 80 kph	Minimal political impact (brief press coverage)	First aid treatment or minor damage to vehicles
3	<b>Moderate</b>	Significant damage	Significant damage	< \$1 M	One lane closed for < 1 day	Speed reduction for > 1 month - 80 kph or < 1 day - 40 kph	Political impact (press coverage)	Medical treatment required
4	<b>Major</b>	Extensive damage	Major damage - restricted speed	< \$10 M	One lane closed for > 1 day	Speed reduction for < 1 month - 40 kph	Significant political impact (extensive negative press coverage)	Extensive injuries or one or two permanent disabilities
5	<b>Catastrophic</b>	Loss of use of carriageway	Extensive damage. One carriageway closed until repaired	< \$50 M	One carriageway closed for > 1 day or both carriageways for < 2 day	Speed reduction for > 1 month - 40 kph	Major political impact (Commission of Enquiry)	Single fatality or severe permanent disabilities to several people
6	<b>Unthinkable</b>		Total failure of bridge or closed until repaired	> \$50 M	Both carriageways closed for > 2 day	Speed restrictions for > 12 months - 40 kph		Multiple fatalities

# ROADS & MARITIME SERVICES

## RISK ASSESSMENT - SUBSIDENCE IMPACTS ON RMS ASSETS

### RISK MATRIX



Transport  
Roads & Maritime  
Services

LIKELIHOOD		CONSEQUENCES					
		1 (Insignificant)	2 (Minor)	3 (Moderate)	4 (Major)	5 (Catastrophic)	6 (Unthinkable)
Multiple	O	H	E	E	E	E	E
Almost Certain	A	H	H	E	E	E	E
Likely	B	M	H	H	E	E	E
Possible	C	L	M	H	E	E	E
Unlikely	D	L	L	M	H	E	E
Rare	E	L	L	M	H	H	E
Hypothetical	F	L	L	L	M	H	H

Low	Low risk; managed by routine procedures.
Moderate	Moderate risk; requires above normal attention.
High	High risk; ALARP must be applied.
Extreme	Extreme risk; not acceptable and must be reduced.

## Appendix E

### Peabody Presentation

# **Advanced Energy**

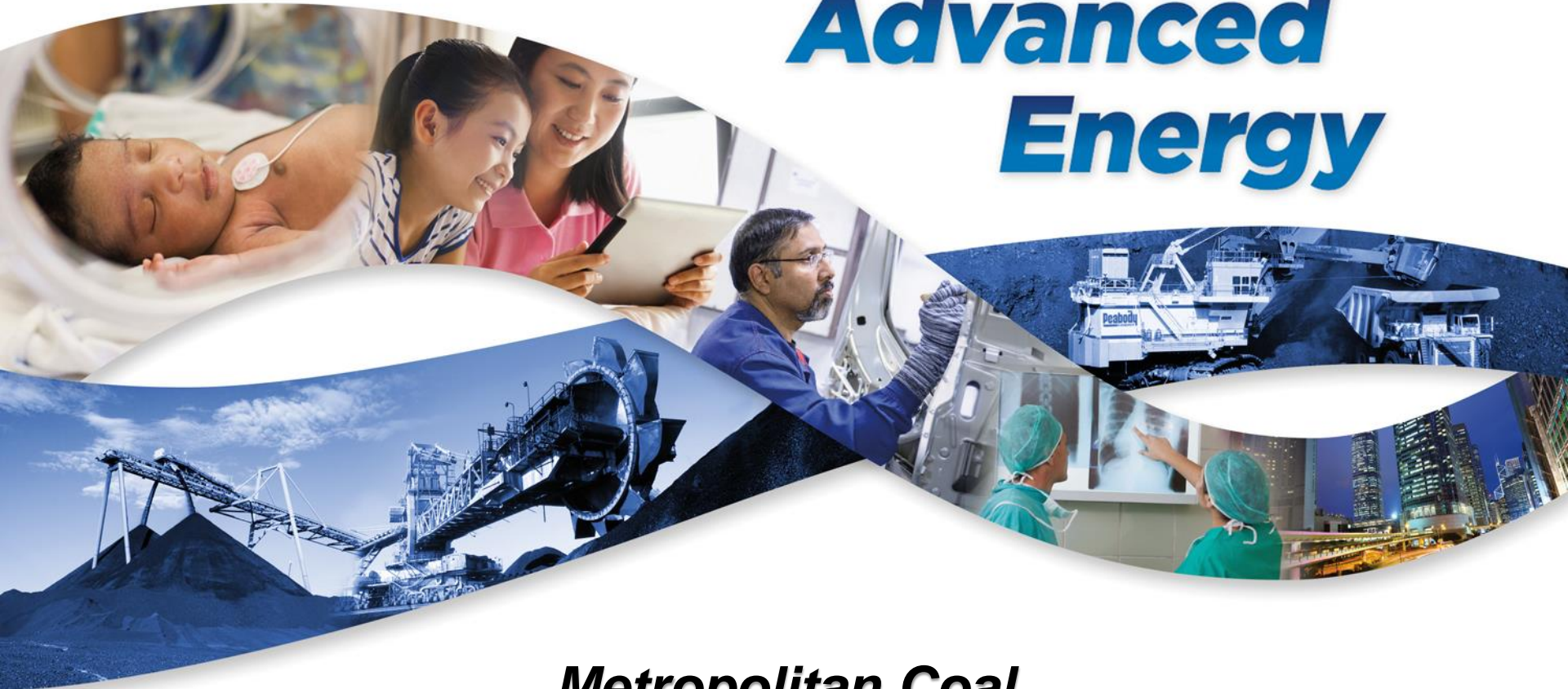

## **Metropolitan Coal Longwalls 301-303 Extraction Plan Built Features Management Plan**

**25 August 2016**

**Jon Degotardi**  
**Technical Services Manager**

**Peabody**  
ENERGY

# Metropolitan Colliery



# Approved Metropolitan Coal Project

## Metropolitan Coal Project EA

- “Project Underground Mining Area” – Blue Line
- Longwalls 301-303 are located **wholly within** the extent of the “Project Underground Mining Area”
- LW20-26 mined to date
- LW27 completion in 2017
- LW301-303 Extraction Plan

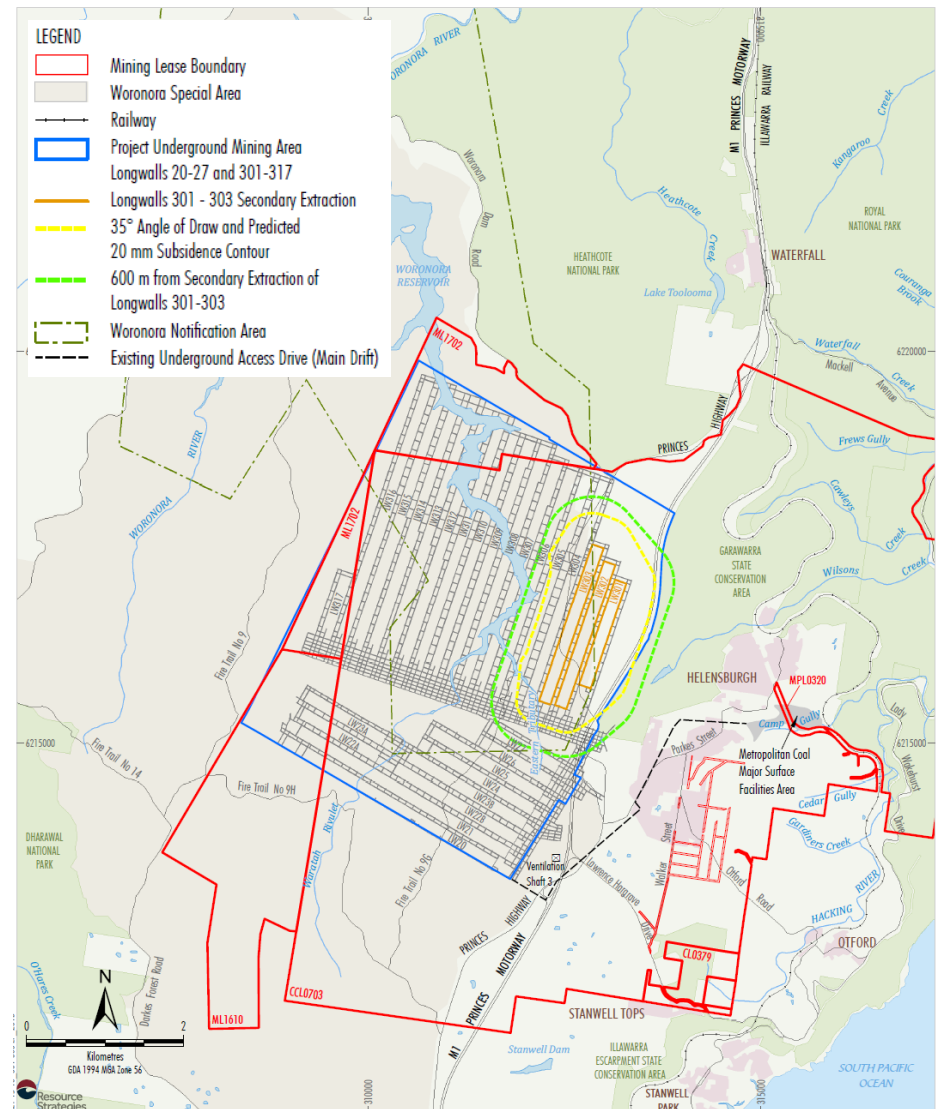

# Approved Metropolitan Coal Project

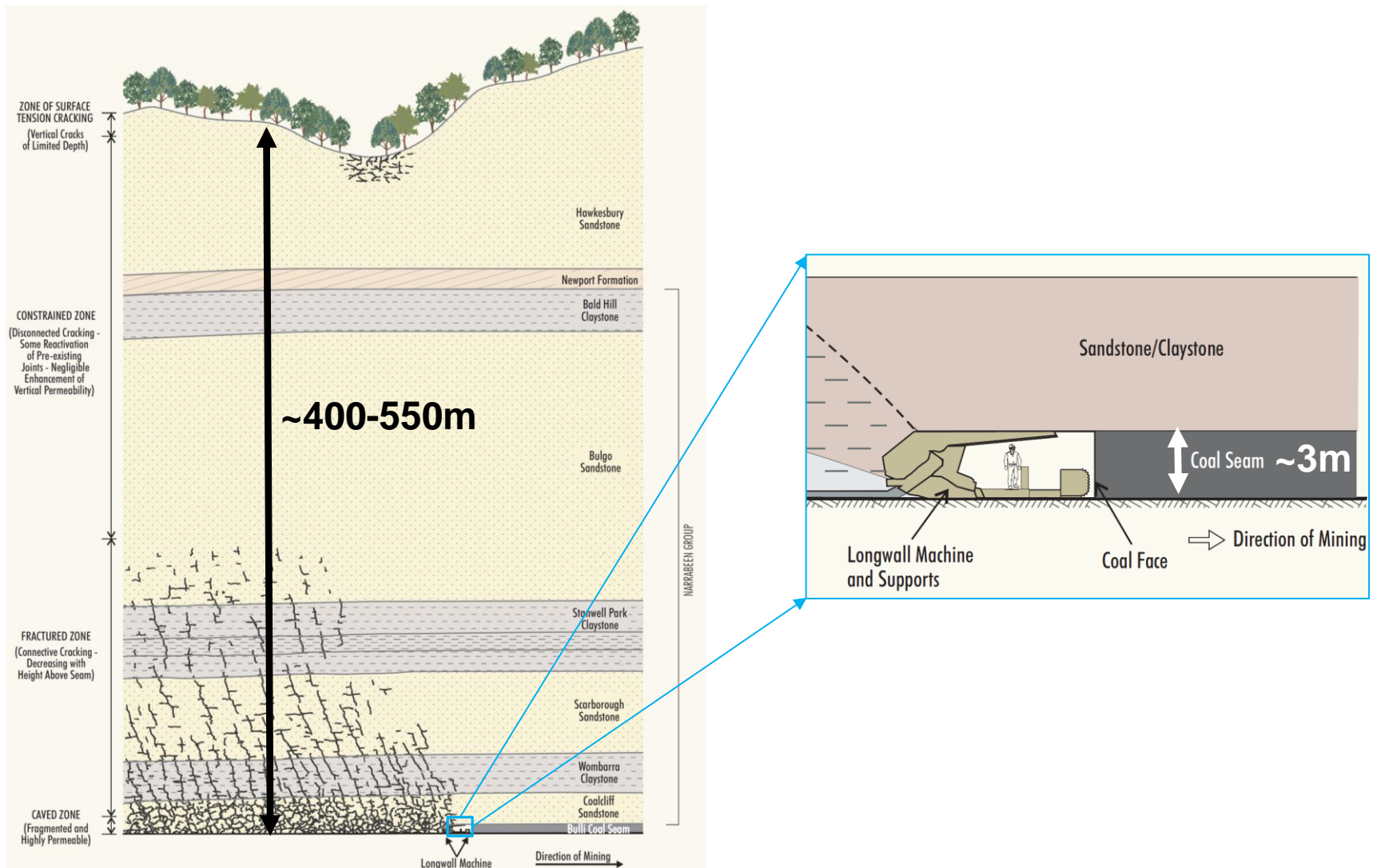

# Existing Extraction Plans (+ Sub-Plans)

- LW23-27 & LW20-22
- **Built Features Management Plan(s)**
  - **Roads and Maritime Services**
- Water Management Plan
- Biodiversity Management Plan
- Land Management Plan
- Heritage Management Plan
- Public Safety Management Plan

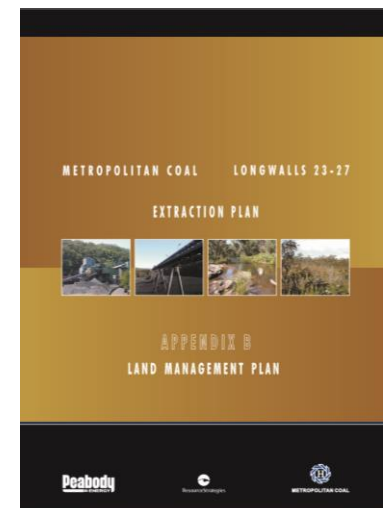
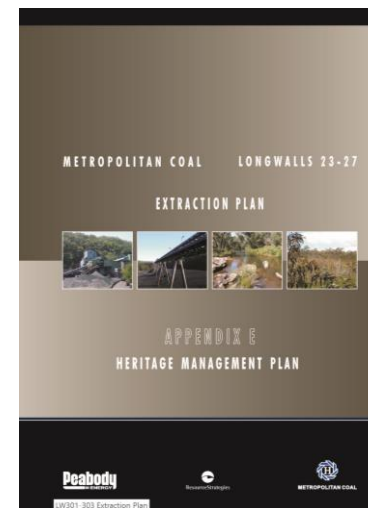
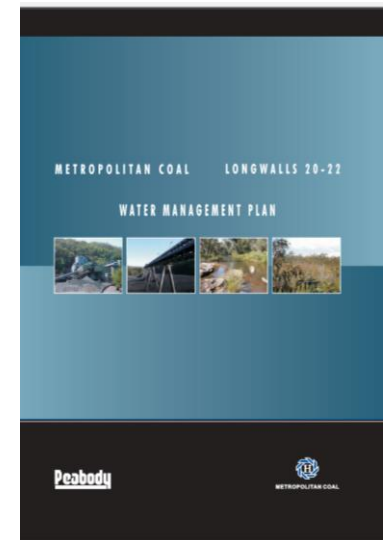
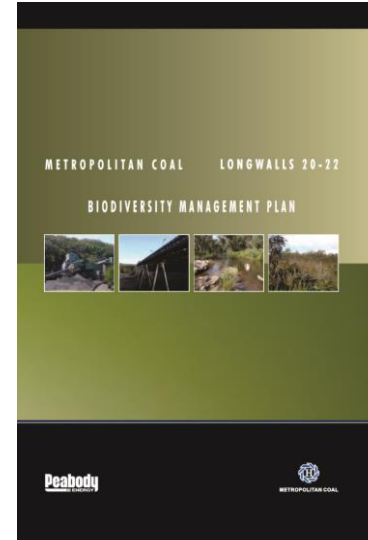

# LW301-303 Extraction Plan

## LW301-303 Extraction Plan - BFMP

- MSEC (11 July 2016) Subsidence Predictions.
- Pavement, Cuttings, Embankments, Culverts
- Bridge 2 (330 m at nearest point)
- Cawley Road Overpass (>1 km)

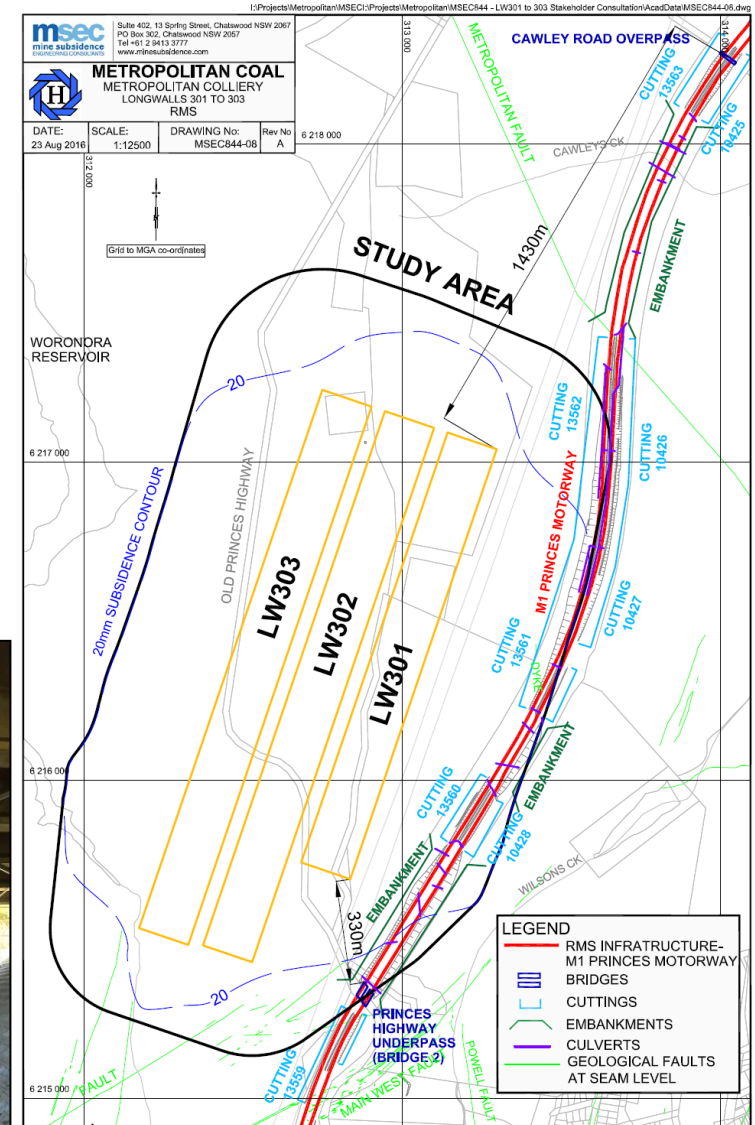

# Approved Metropolitan Coal Project

## LW301-303 Extraction Plan

- Up to 50 mm vertical subsidence resulting from the extraction of Longwalls 301 to 303.
- Maximum predicted conventional tilts and curvatures are less than expected levels of survey tolerance.
- Far-field horizontal movements of up to 115 mm (based on 95% confidence level).
- Geological features include Metropolitan Fault (north-east), dyke with surface exposure in cutting and other mapped faults (south-east).

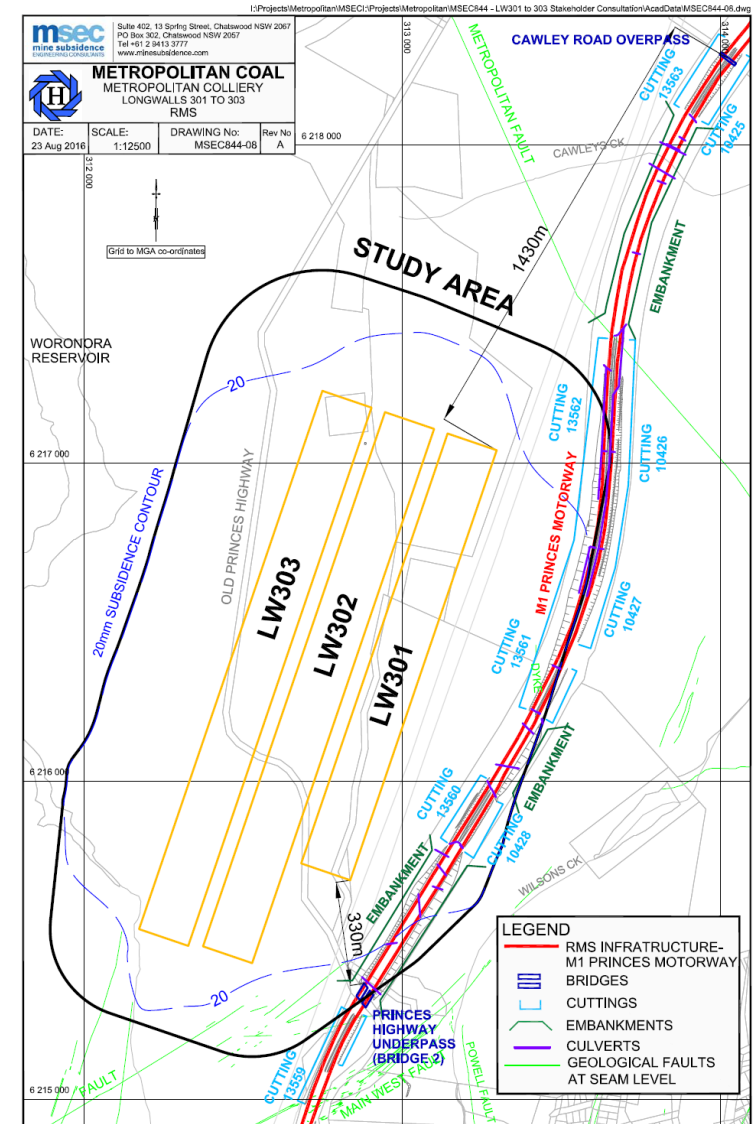

# Approved Metropolitan Coal Project

## LW301-303 Extraction Plan

- Valley closure is not expected to occur in the cuttings along the M1 Princes Motorway (however minor closure movements could be observed due to horizontal movements).
- Expected the M1 Princes Motorway can be maintained in safe and serviceable conditions with implementation of monitoring and management strategies (in consultation with RMS).
- At distance, Cawley Road Overpass is unlikely to experience adverse impacts.
- Bridge 2 (330 m at nearest point) to continue program of high accuracy monitoring.

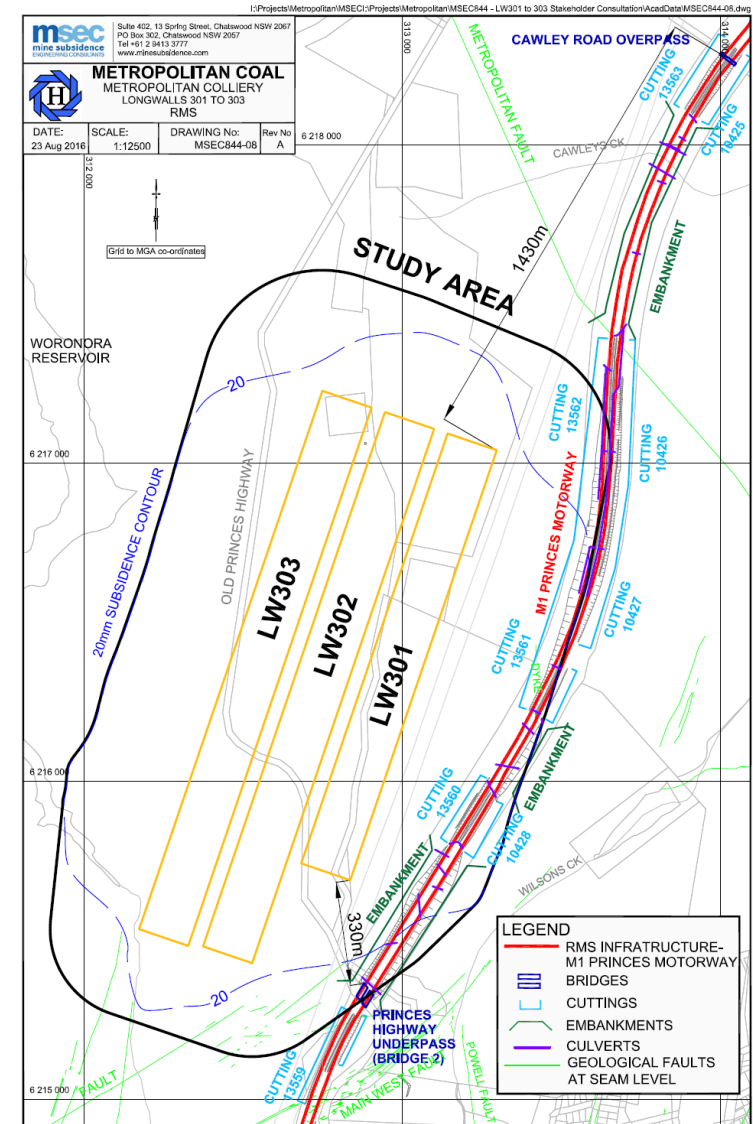

# LW301-303 Extraction Plan

## Project Approval Condition

- The subsidence impact performance measure specified in Table 1 of Condition 1, Schedule 3 in relation to built features is:

*Safe, serviceable and repairable, unless the owner and the MSB agree otherwise in writing.*

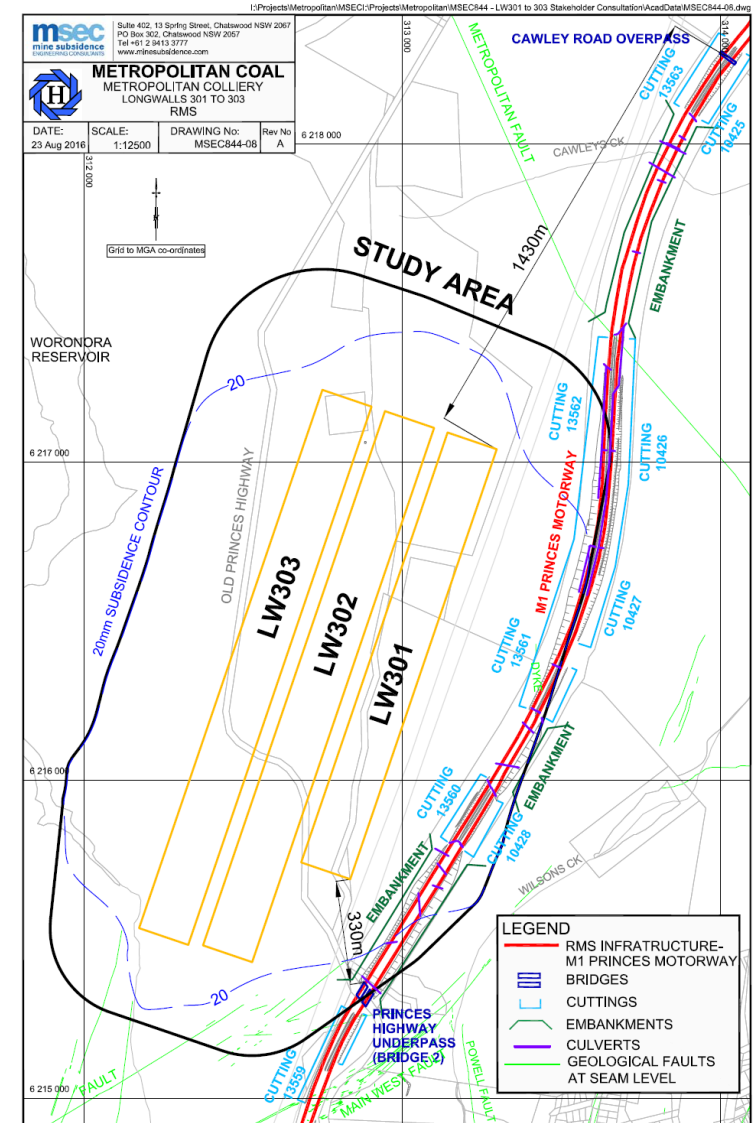

# LW301-303 Extraction Plan

## Monitoring Plan

- Subsidence Lines
  - M1 Princes Motorway
  - Transmission Line

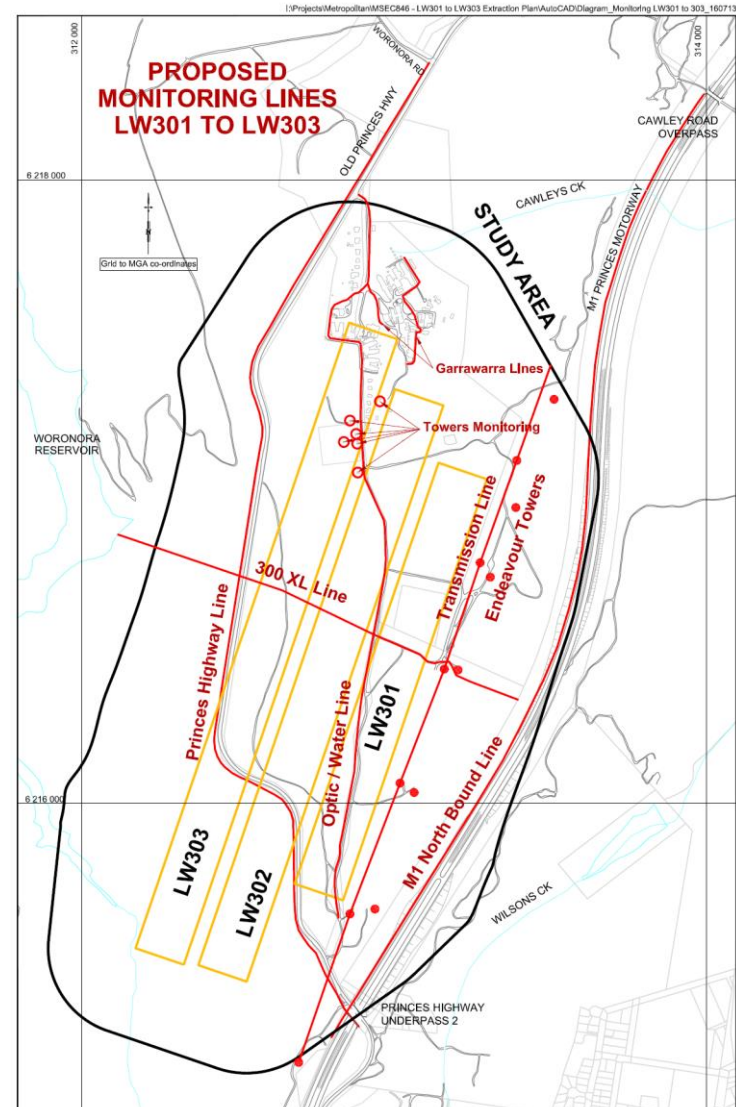



# ***Advanced Energy***



***PeabodyEnergy.com  
AdvancedEnergyForLife.com***

## Appendix F

### MSEC Report

6<sup>th</sup> September 2016

Jon Degotardi  
Peabody Energy Australia  
Metropolitan Colliery  
PO Box 402  
Helensburgh NSW 2508

Ref: MSEC844-08

Dear Jon,

**RE: Metropolitan Colliery – Proposed Longwalls 301 to 303 - Subsidence Predictions and Impact Assessments for the Roads and Maritime Services Infrastructure**

This letter report summarises the predicted subsidence movements and the assessed subsidence impacts for the Roads and Maritime Services (RMS) infrastructure resulting from the extraction of the proposed Longwalls 301 to 303 at Metropolitan Colliery.

The locations of the RMS infrastructure and the proposed longwalls are shown in the attached Drawing No. MSEC844-08. The M1 Princes Motorway is located to the east of Longwalls 301 to 303. The distance of the M1 Princes Motorway from Longwalls 301 to 303 varies from 210 metres near the finishing (southern) end of Longwall 301 to 335 metres near the commencing (northern) end of Longwall 301.

A series of cuttings and embankments up to a maximum height of approximately 20 metres are shown in the attached Drawing No. MSEC844-08. A summary of the rock cuttings is provided in Table 1.

**Table 1 Summary of RMS Rock Cuttings**

RMS Slope Number	RMS Assessed Risk Level (ARL)	Length (m)	Maximum Slope Height (m)	Average Slope Angle (degrees)
13563	2	202	17	65
13562	2	531	18	70
13561	2	599	13	62
13560	2	231	8	70
10425	2	188	9	66
10426	2	503	15	55
10427	2	452	14	55
10428	2	192	9	65

A bridge is located at the crossing of the M1 Princes Motorway with the Old Princes Highway (Bridge 2), and is located approximately 330 metres from Longwall 301. The next nearest bridge is Cawley Road Overpass, which is located approximately 1.43 kilometres to the north east of Longwall 303.

A series of culverts cross the M1 Princes Motorway, as shown on Drawing No. MSEC844-08. The culverts comprise pipes of varying diameters from 375 mm to 1800 mm. The pipe materials comprise asbestos cement (pipes up to

600 mm diameter) and steel reinforced concrete (pipes up to 1800 mm diameter). In addition to the culverts, there are also a number of other drainage structures, such as kerbs, gutters, pits and drainage pipes. The largest culvert comprises two 1800mm pipes located to the north east of the longwalls at Cawley's Creek.

The predictions and impact assessments for the RMS infrastructure are provided in the following sections.

### Conventional Subsidence Parameters for the RMS Infrastructure

A summary of the maximum predicted values of total subsidence, tilt and curvature for the M1 Princes Motorway, resulting from the extraction of Longwalls 301 to 303, is provided in Table 2. The values are the maxima anywhere along the section of the motorway located within the Study Area.

**Table 2 Predicted Total Subsidence, Tilt and Curvature for the M1 Princes Motorway Resulting from the Extraction of Longwalls 301 to 303**

Longwall	Maximum Predicted Total Conventional Subsidence (mm)	Maximum Predicted Total Conventional Tilt (mm/m)	Maximum Predicted Total Conventional Hogging Curvature (km <sup>-1</sup> )	Maximum Predicted Total Conventional Sagging Curvature (km <sup>-1</sup> )
After LW301	< 20	< 0.5	< 0.01	< 0.01
After LW302	50	< 0.5	< 0.01	< 0.01
After LW303	50	< 0.5	< 0.01	< 0.01

The maximum predicted conventional tilt and curvature are negligible and less than typical limits of survey accuracy (i.e. 0.5 mm/m for tilt and 0.01 km<sup>-1</sup> for curvature).

Princes Motorway will potentially experience low level far-field horizontal movement. The far-field horizontal movements are expected to be similar to those observed for previous longwall mining in the Southern Coalfield.

The observed incremental far-field horizontal movements, resulting from the extraction of longwalls in the Southern Coalfield, are provided in Figure 1. The data are based on survey marks located outside of the mining area (i.e. above solid coal).

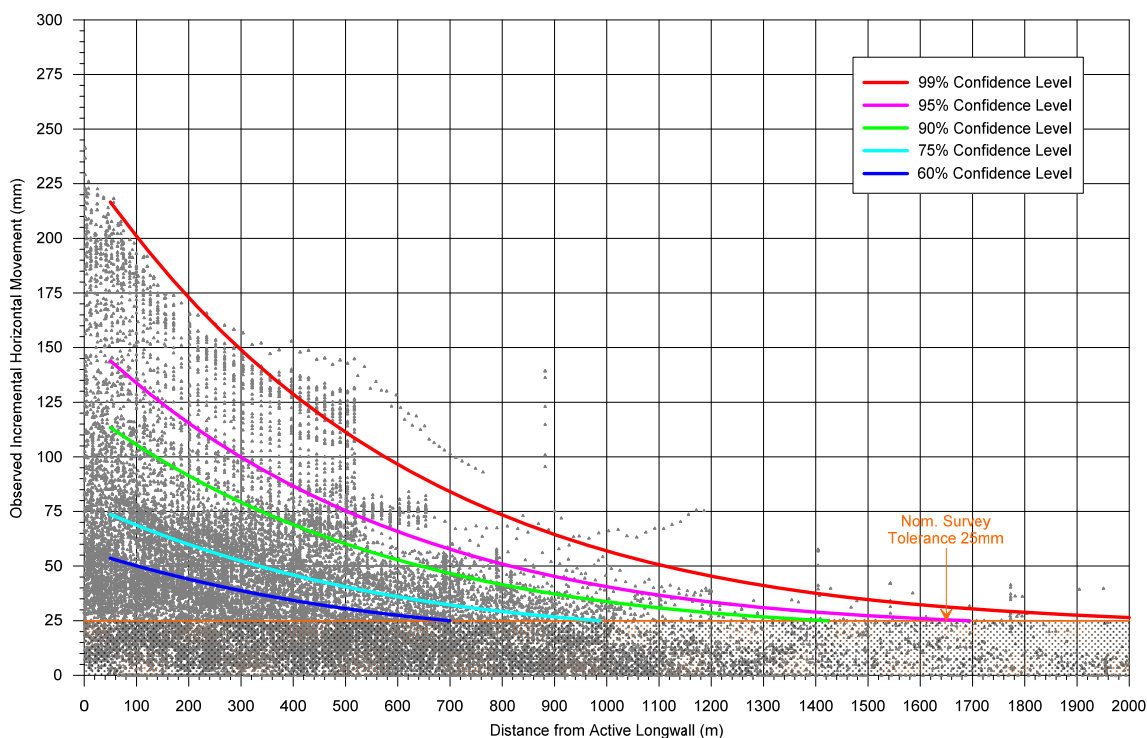

**Figure 1 Observed Incremental Far-field Horizontal Movements from the Southern Coalfield (Solid Coal)**

The absolute horizontal movements measured at distances greater than 210 metres from mining are in the order of 115 mm based on the 95 % confidence level. These low level movements comprise a large proportion of survey tolerance. Far-field horizontal movements tend to be bodily movements orientated towards the mining area. The strains associated with these low level horizontal movement are not expected to be measurable.

### **Predicted Strains**

The prediction of strain is more difficult than the predictions of subsidence and tilt. The reason for this is that strain is affected by many factors, including ground curvature and horizontal movement, as well as local variations in the near surface geology, the locations of pre-existing natural joints at bedrock and the depth of bedrock. Survey tolerance can also represent a substantial portion of the measured strain, in cases where the strains are of a low order of magnitude. The profiles of observed strain, therefore, can be irregular even when the profiles of observed subsidence, tilt and curvature are relatively smooth.

In previous MSEC subsidence reports, predictions of conventional strain were provided based on the best estimate of the average relationship between curvature and strain. Similar relationships have been proposed by other authors. The reliability of the strain predictions was highlighted in these reports, where it was stated that measured strains can vary considerably from the predicted conventional values.

Adopting a linear relationship between curvature and strain provides a reasonable prediction for the conventional tensile and compressive strains. In the Southern Coalfield, it has been found that a factor of 15 provides a reasonable relationship between the predicted maximum curvatures and the predicted maximum conventional strains. The locations that are predicted to experience hogging or convex curvature are expected to be net tensile strain zones and locations that are predicted to experience sagging or concave curvature are expected to be net compressive strain zones.

At a point however, there can be considerable variation from the linear relationship, resulting from non-conventional movements or from the normal scatters which are observed in strain profiles. When expressed as a percentage, observed strains can be many times greater than the predicted conventional strain for low magnitudes of curvature. We have therefore provided a statistical approach to account for the variability, instead of just providing a single predicted conventional strain.

The range of predicted strains for the RMS infrastructure has been determined using the monitoring data from Metropolitan Colliery and other nearby collieries. The data used in the analysis of observed strains included those resulting from both conventional and non-conventional anomalous movements, but did not include those resulting from valley related movements. The strains resulting from damaged or disturbed survey marks have also been excluded.

The M1 Princes Motorway is located at distances of 200 metres or greater from the longwalls. The database of measured strains has therefore been analysed to extract the maximum tensile and compressive strains that have been measured at any time during the extraction of the previous longwalls in the Southern Coalfield, for survey bays that were located outside and within 100 metres to 250 metres of the nearest longwall goaf edge, which has been referred to as "*above solid coal*".

A histogram of the maximum observed tensile and compressive strains measured in survey bays located above solid coal, for monitoring lines in the Southern Coalfield, is provided in Figure 2. The probability distribution functions, based on a fitted *Generalised Pareto Distribution (GPD)*, have also been shown in this figure.

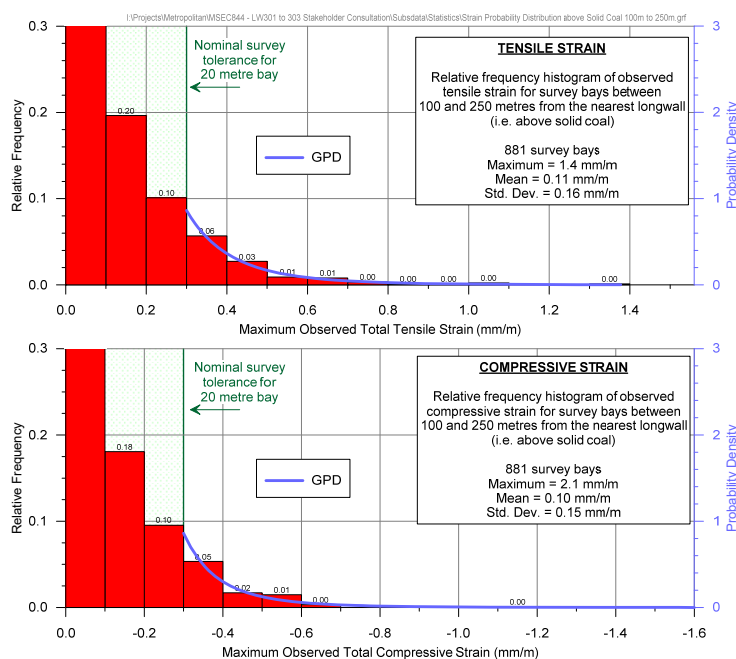

**Figure 2 Distributions of the Measured Maximum Tensile and Compressive Strains during the Extraction of Previous Longwalls in the Southern Coalfield Above Solid Coal (100 to 250 metres)**

Confidence intervals have been determined from the empirical strain data using the fitted GPDs. In the cases where survey bays were measured multiple times during a longwall extraction, the maximum tensile strain and the maximum compressive strain were used in the analysis (i.e. single tensile strain and single compressive strain measurement per survey bay).

A summary of the probabilities of exceedance for tensile and compressive strains for survey bays located above solid coal, based on the fitted GPDs, is provided in Table 3.

**Table 3 Probabilities of Exceedance for Strain for Survey Bays Located above Solid Coal**

Strain (mm/m)		Probability of Exceedance
Compression	-2.0	1 in 9,840
	-1.5	1 in 3000
	-1.0	1 in 635
	-0.5	1 in 55
	-0.3	1 in 10
Tension	+0.3	1 in 9
	+0.5	1 in 36
	+1.0	1 in 410
	+1.5	1 in 2,200
	+2.0	1 in 8,000

The 95 % confidence intervals for the maximum total strains that the individual survey bays above solid coal (100 to 250 metres) experienced at any time during mining are 0.4 mm/m tensile and compressive. The 99 % confidence intervals for the maximum total strains that the individual survey bays above solid coal experienced at any time during mining are 0.7 mm/m tensile and 0.6 mm/m compressive.

## Potential for Non-Conventional Movements

Non-conventional movements can develop due to the presence of geological structures or valley related effects. In some cases, non-conventional movements can develop with no known cause and these are often referred to as 'anomalous' movements.

The locations of the known geological structures and the streams are shown in Drawing No. MSEC844-08.

There are no identified geological structures above the longwalls. The M1 Princes Motorway crosses the Metropolitan Fault approximately 500 metres to the north east of Longwall 301 and several faults to the south east of Longwalls 301 and 302 intersecting the M1 Princes Motorway at approximately 340 metres. The absolute horizontal movements measured at distances of 500 metres and 340 metres from mining are in the order of 75 mm and 95 mm respectively based on the 95 % confidence level. It is noted that these faults are identified at seam level and surface expression of faults may occur at different locations, or faults may not have continuity to the ground surface.

A drainage line crosses the M1 Princes Motorway approximately 210 metres east of the finishing end of Longwall 301, as shown on Drawing No. MSEC844-08. Predicted valley closure across the culvert at the location of the M1 Princes Motorway is less than 20 mm.

A second drainage line is located to the north of the longwalls at Cawley's Creek. Due to the shortened commencing end of the longwalls, the culvert is located approximately 1060 metres from the nearest longwall (Longwall 301). At this distance, the culvert is not predicted to experience valley related movements due to the extraction of the Longwalls 301 to 303.

Valley closure is not expected to occur in the cuttings along the M1 Princes Motorway, however, minor closure movements could be observed due to potential horizontal movements.

## Impact Assessments for the M1 Princes Motorway

The predicted conventional vertical subsidence for the M1 Prince Motorway resulting from the extraction of Longwalls 301 to 303 are very small and the predicted tilts and curvatures are less than the expected limits of survey tolerance. Adverse impacts to the M1 Princes Motorway, including the road pavement, slopes, culverts, barriers and furniture, resulting from conventional subsidence movements is considered unlikely.

The M1 Princes Motorway will potentially experience far-field horizontal movements resulting from the extraction of the Longwalls 301 to 303 of up to 115 mm, based on the 95% confidence level.

There are no major geological features to the east of the longwalls near the M1 Princes Motorway. The mapped geological features are shown on Drawing No. MSEC846-08. The Metropolitan Fault intersects the M1 Princes Motorway at approximately 500 metres to the north east of Longwall 301. There are mapped faults to the south east of Longwalls 301 and 302, intersecting the M1 Princes Motorway at approximately 340 metres from the longwalls. A dyke with a surface exposure is also present to the east of Longwall 301 at approximately 380 metres from Longwall 301. There is the potential for far-field horizontal movements to result in the minor differential movement near the faults and potential shearing and/or stepping in the road pavement. The faults have been mapped at seam level and surface expressions have not been identified. The mapped dyke has been identified in the motorway cuttings. There is also the potential for far-field horizontal movements to result in differential movement at the interface of cut and fill areas along the motorway corridor.

The M1 Princes Motorway crosses a valley and an associated drainage culvert to the east of the Longwall 301 finishing end. The predicted valley closure due to Longwalls 301 to 303 is less than 20 mm. A second valley and culvert are located at Cawley's Creek, approximately 930 metres from Longwall 303. Adverse impacts to the culverts resulting from conventional subsidence and valley related movements is considered unlikely.

It is recommended that monitoring and management strategies are developed, in consultation with RMS, to manage the potential impacts on the M1 Princes Motorway. It is expected that the motorway can be maintained in safe and serviceable conditions with the implementation of the appropriate monitoring and management strategies.

## Impact Assessments for the Bridges

An assessment of Bridge 2 (RMS reference BN616-southbound and BN617-northbound) has been undertaken by the RMS technical committee, which was formed prior to the commencement of the extraction of Longwall 20 to assess and monitor potential impacts to RMS assets due to the extraction of longwalls at Metropolitan Colliery. A letter report MSEC696-02 dated 30<sup>th</sup> June 2014 was prepared based on a preliminary layout of Longwalls 301 to 317. The distance of the bridge from the longwalls is unchanged at 330 metres hence the impact assessments are the same as previously reported. A summary of the subsidence predictions and impact assessments for Bridge 2 is provided below.

- At a distance of approximately 330 metres, the predicted subsidence parameters are less than survey tolerance, which is typically 20mm for subsidence, 0.5mm/m for tilt and 0.01km<sup>-1</sup> for curvature. The predicted conventional subsidence parameters indicate that with high accuracy survey, minor subsidence, tilt and hogging curvature may be observed, but sagging curvature is unlikely to be observed.
- The absolute horizontal movements measured at distances greater than 330 metres are in the order of 95 mm based on the 95% confidence level. An absolute horizontal movement of 105 mm based on the 95% confidence level was provided in the MSEC696-02 report. The updated data set as presented in Figure 1 results in a slightly lower value of observed horizontal movement, however the difference of 10 mm does not change the impact assessments for the bridge.
- It is difficult to predict differential horizontal movements since the potential values of relative movement are typically very small and much of the scatter in the observed data is the result of survey accuracy. Also, a spacing between pegs of 20 metres is commonly used along monitoring lines, and this distance is larger than the typical column and blade wall spacing for Bridge 2.
- Differential horizontal movement was assessed by analysing the far-field horizontal movement data discussed above. The data set was analysed to determine incremental relative opening and closing and incremental mid ordinate deviation.
- The incremental relative opening and closing and mid ordinate deviation for various probabilities at a distance of approximately 330 metres from an active longwall are summarised in Table 4 and Table 5.

**Table 4 Incremental Relative Opening, Closing and Mid-Ordinate Deviation at Approximately 330 metres Distance from Active Longwall**

	1 in 20 probability (95% confidence level)	1 in 100 probability (99% confidence level)	1 in 2000 probability (99.95% confidence level)
Opening	8 mm	14 mm	44 mm
Closing	6 mm	13 mm	44 mm
Mid-Ordinate Deviation	9 mm	15 mm	32 mm

**Table 5 Incremental Relative Opening, Closing and Mid-Ordinate Deviation due to First Panel Extraction Only**

	1 in 20 probability (95% confidence level)	1 in 100 probability (99% confidence level)	1 in 2000 probability (99.95% confidence level)
Opening	5 mm	10 mm	25 mm
Closing	4 mm	9 mm	32 mm
Mid Ordinate Deviation	5 mm	8 mm	14 mm

- The differential movements presented in Table 4 and Table 5 should be applied to the bridge elements in both the longitudinal and transverse direction of the bridge. The application of the differential movements to short bridge element spacing (e.g. columns approximately 5m apart), was discussed by the technical committee and it was agreed that the movements should be applied directly to shorter element spacing.
- The differential longitudinal movement, opening (+ve) and closing (-ve) should be applied to the longitudinal and transverse direction as an opening and closing movement, between piers, and between columns. The mid-ordinate deviation should be applied to an out of plane movement of one pier relative to adjacent piers, which are spaced at 13.5 metres at abutments and 18.3 metres in the centre, as well as between columns which are approximately 5 metres apart.
- Faults have been identified at seam level to the west and to the east of Bridge 2. The nearest faults, Main West and Powel are approximately 235 metres horizontal distance from Bridge 2. There are no mapped surface expressions of the faults. The projected alignments of these faults do not intersect the location of Bridge 2. There is a low likelihood of the identified structures directly impacting Bridge 2, however other potential unidentified structures may be present at or near the bridge location.

A decision was made by the RMS technical committee to monitor potential movements of Bridge 2 using a high accuracy fibre optic monitoring system, along with conventional surveying methods. The monitoring system is being established to record baseline readings during the extraction of Longwalls 26 and 27, prior to the commencement of Longwall 301.

Cawley Road Overpass is located at 1.43 kilometres from Longwall 301 at its nearest point. At this distance, observed far-field movements as shown in Figure 1 are close to nominal survey tolerance and observed differential movement data is predominantly within survey tolerance. Differential horizontal movement was assessed by analysing the far-field horizontal movement data. The data set was analysed to determine incremental relative opening and closing and incremental mid ordinate deviation at a distance of approximately 1.43 kilometres from an active longwall.

The incremental relative opening and closing and mid ordinate deviation for various probabilities at a distance of approximately 1.43 kilometres from an active longwall are summarised in Table 6.

**Table 6 Incremental Relative Opening, Closing and Mid-Ordinate Deviation at Approximately 1.43 kilometres Distance from Active Longwall**

	1 in 20 probability (95% confidence level)	1 in 100 probability (99% confidence level)	1 in 2000 probability (99.95% confidence level)
Opening	4 mm	7 mm	14 mm
Closing	5 mm	9 mm	19 mm
Mid-Ordinate Deviation	7 mm	10 mm	18 mm

At this distance, adverse impact to Cawley Road Overpass resulting from the extraction of Longwalls 301 to 303 is considered unlikely, however an assessment of the structure should be undertaken to assess the sensitivity of the structure to potential differential movements a result of Longwalls 301 to 303.

## Summary

The M1 Princes Motorway is located greater than 210 metres to the east of Longwalls 301 to 303. The previous experience from the Southern Coalfield has found that the potential impacts on bitumen seal and asphaltic pavements can be managed with the implementation of suitable monitoring and management strategies.

It is recommended that monitoring and management strategies are developed, in consultation with RMS, to manage the potential impacts on the M1 Princes Motorway. It is expected that the motorway can be maintained in safe and serviceable conditions with the implementation of the appropriate monitoring and management strategies.

Bridge 2 is located approximately 330 metres from Longwall 301. A program of high accuracy monitoring of this bridge has been implemented by the RMS technical committee and will be outlined in the Built Features Management Plan for Longwalls 301 to 303. The culverts and Cawley Road Overpass are located outside the predicted 20 mm subsidence contour. Whilst these features could experience low level far-field horizontal movements, they are not expected to experience measurable strains or differential horizontal movements. Assessment of these structures should be undertaken by the RMS technical committee to assess the sensitivity of these structures to potential differential movements a result of Longwalls 301 to 303.

Yours sincerely

Peter DeBono

Mine Subsidence Engineering Consultants

Attachments:

Drawing No. MSEC844-08 – Longwalls 301 to 303 – RMS Infrastructure



Suite 402, 13 Spring Street, Chatswood NSW 2067  
 PO Box 302, Chatswood NSW 2057  
 Tel +61 2 9413 3777  
 www.minesubsidence.com



**METROPOLITAN COAL**  
 METROPOLITAN COLLIERY  
 LONGWALLS 301 TO 303  
 RMS

DATE: 23 Aug 2016	SCALE: 1:12500	DRAWING No: MSEC844-08	Rev No A
----------------------	-------------------	---------------------------	-------------

6 218 000

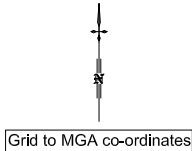

WORONORA RESERVOIR

6 217 000

6 216 000

6 215 000

20mm SUBSIDENCE CONTOUR

OLD PRINCES HIGHWAY

LW303

LW302

LW301

STUDY AREA

1430m

330m

PRINCES HIGHWAY UNDERPASS (BRIDGE 2)

CAWLEY ROAD OVERPASS

METROPOLITAN FAULT

CAWLEYS CK

WILSONS CK

**LEGEND**

- RMS INFRASTRUCTURE- M1 PRINCES MOTORWAY
- BRIDGES
- CUTTINGS
- EMBANKMENTS
- CULVERTS
- GEOLOGICAL FAULTS AT SEAM LEVEL

CUTTING 13563

CUTTING 10425

EMBANKMENT

CUTTING 13562

CUTTING 10426

M1 PRINCES MOTORWAY

CUTTING 10427

CUTTING 13561

EMBANKMENT

CUTTING 13560

CUTTING 10428

FAULT

MAIN WEST FAULT

POWELL FAULT

314 000

313 000

312 000

APPENDIX 6

METROPOLITAN COLLIERY LONGWALL MINING – LW 304-306 RISK ASSESSMENT AS  
APPLIED TO RMS ASSETS

Metropolitan Coal – LW305-307 Built Features Management Plan – Roads and Maritime Services		
Revision No. BFMP_TFNSW-R01-D		
Document ID: Built Features Management Plan - TFNSW		

Roads & Maritime Services

**Metropolitan Colliery Longwall  
Mining – LW304-306**

**Risk Assessment as Applied to RMS  
Assets**

264172/REP/001

ISSUE | 7 February 2019

This report takes into account the particular instructions and requirements of our client.

It is not intended for and should not be relied upon by any third party and no responsibility is undertaken to any third party.

Job number 264172-00

Arup  
Arup Pty Ltd ABN 18 000 966 165



**Arup**  
Level 17  
1 Nicholson Street  
East Melbourne VIC 3002  
Australia  
[www.arup.com](http://www.arup.com)

**ARUP**



## Contents

---

	Page	
<b>1</b>	<b>Introduction</b>	<b>1</b>
<b>2</b>	<b>Description of Proposed Mining</b>	<b>1</b>
<b>3</b>	<b>RMS Assets Affected</b>	<b>3</b>
	3.1 Predicted Ground Movements	4
	3.2 Assessment of Ground Movement Impacts	5
<b>4</b>	<b>Risk Workshop</b>	<b>6</b>
<b>5</b>	<b>Results</b>	<b>7</b>
	5.1 Carriageway	8
	5.2 Culverts	8
	5.3 Cuttings	8
	5.4 Bridge and Overpass	9
<b>6</b>	<b>Conclusions</b>	<b>9</b>

## Appendices

### Appendix A

Risk Register

### Appendix B

Workshop Participants

### Appendix C

Workshop Agenda

### Appendix D

Risk Criteria

### Appendix E

Peabody BFMP Presentation

### Appendix F

MSEC Subsidence Report

## 1 Introduction

---

Arup has been engaged by Roads & Maritime Services (RMS) to undertake a risk assessment with regards to the impacts on RMS assets arising from subsidence due to the mining of longwalls LW304-306 in the Metropolitan Mine which is owned by a subsidiary of Peabody Energy (Peabody).

Previous risk assessments were completed in 2009, 2013 and 2016 on the impacts of subsidence from LW20-22, LW23-27 and LW301-303 respectively. A history of the impacts of subsidence has been gained, along with knowledge about the performance of mitigation control measures applied and the reliability of the monitoring systems utilised.

As with the previous assessments, the concern of RMS is the possible impacts from the mining of LW304-306 on its surface assets with a specific emphasis on how the mining might result in financial loss to RMS, loss of functionality of the assets with regards to the road users (motorists and public) and possible life safety issues, should the mining adversely impact on any of the assets.

The process adopted by Arup follows closely the principles set out in AS/NZS ISO31000:2009 – Risk Management, and the various standards of RMS, specifically those relating to the assessment of risks posed by subsidence mining.

Arup facilitated a workshop with relevant stakeholders to firstly identify the assets at risk and then ascertain the risks posed to those assets from the mining of LW304-306. This same workshop also considered various mitigation and control measures and determined the effectiveness of these in reducing risk levels.

The events and activities identified in the workshop will be addressed and managed in the Built Features Management Plan for LW304-306.

## 2 Description of Proposed Mining

---

Peabody, or Metropolitan Colliery (MC), proposes to extract longwalls LW304-306 as part of its ongoing underground coal mining operations within the Bulli Seam at the Metropolitan Mine. The mine is located in the Southern Coalfield of New South Wales. The overall layout of longwalls LW304-306 is shown in Figure 1.

[I:\Projects\Metropol\lan\MSEC958 - LW304 to 306 Revised Layout\AcadData\MSEC958-101 Longwall Setbacks.dwg

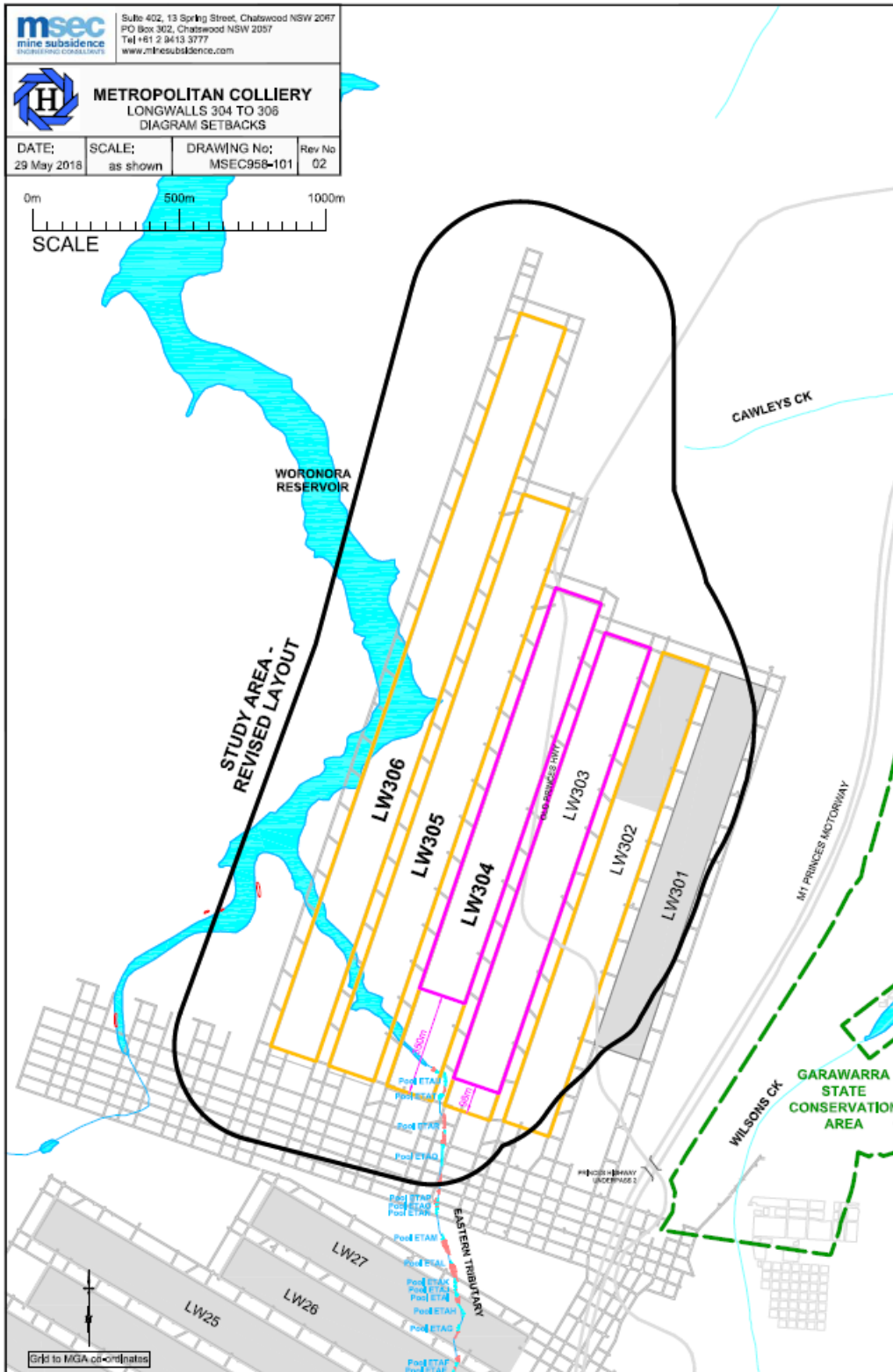

Figure 1: Layout of LW304-306

### 3 RMS Assets Affected

Figure 1 shows the extent of the proposed mining in relation to the RMS assets located along the Princes Motorway.

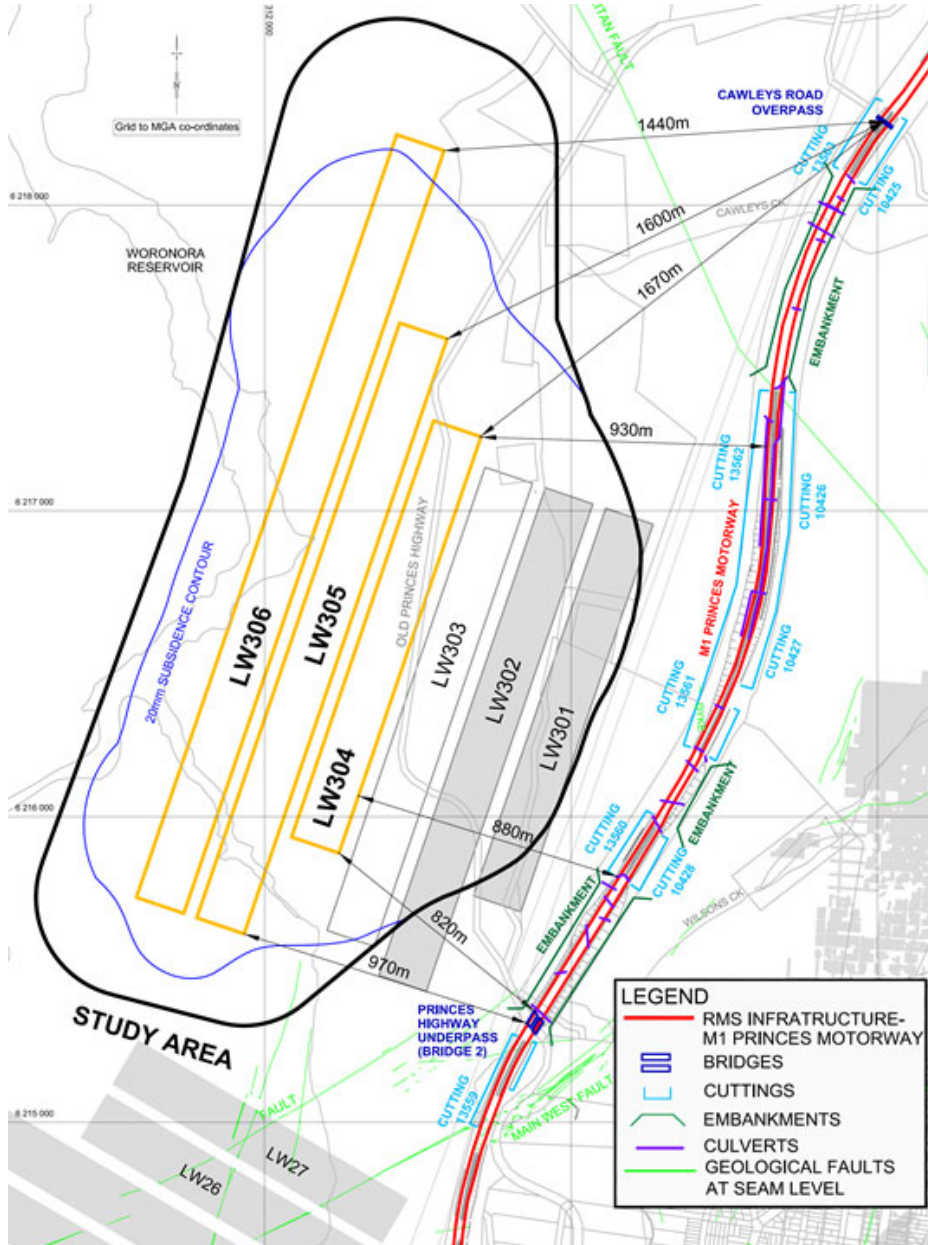

Figure 2: Plan position of RMS Assets to LW304-6

The RMS guidelines [Ref 1] define the zone of interest for infrastructure impacts as being five times the depth of cover. With a depth of cover of approximately 400 m, the zone of interest extends some 2 km from the longwalls.

The M1 Princes Motorway is located to the east of LW304-306. The distance of the M1 from LW304-306 varies from 800 m near the finishing (southern) end of LW304 to 903 m near the commencing (northern) end of LW304.

There are a series of cuttings and embankments up to a maximum height of approximately 20 m along the M1.

There are two bridges (BN616/617- shown as Bridge 2 in Figure 2) carrying the northbound and southbound traffic on the M1 Princes Motorway over the old Princes Highway and these are located approximately 820 m from the southern end of LW304. The next nearest bridge is Cawley Road Overpass (BN615), which is located approximately 1.44 km to the east of LW306, at its nearest point to the mining.

A series of culverts of varying diameters from 375 mm to 1800 mm cross the M1 Princes Motorway. A number of the culverts are asbestos cement pipes. In addition to the culverts, there are also a number of other drainage structures, such as kerbs, gutters, pits and drainage pipes. The largest culvert comprises two 1800 mm pipes located to the north east of the longwalls at Cawley's Creek.

It should be noted the two large culverts and Cawley Road Overpass are located well outside the predicted 20 mm subsidence contour.

### 3.1 Predicted Ground Movements

Mine Subsidence Engineering Consultants Pty Ltd (MSEC) presented their predictions of ground movements for RMS assets from the mining of LW304-306, and a broad assessment of impact on the assets in a report which is included as Appendix F.

#### 3.1.1 Movements Affecting the M1 Motorway

The following is a summary of the ground movement predictions for the M1 Motorway:

- As with LW301-3, the maximum predicted conventional tilt and curvature are less than the expected limits of survey accuracy (i.e. 0.5 mm/m for tilt and  $0.01 \text{ km}^{-1}$  for curvature).
- The M1 will potentially experience far-field horizontal movements of up to 45 mm, based on a 95% confidence level, from a database of observed far-field horizontal movements in the Southern Coalfield.
- Similarly, from the Southern Coalfields survey database, the 95% confidence intervals for the maximum total strains that the individual survey bays above solid coal (100-250 m) experienced at any time during mining are 0.4mm/m tensile and compressive.
- Predicted valley closure across the culvert to the east of the finishing end of Longwall 301 is less than 20 mm.
- Valley closure is not expected to occur in the cuttings along the M1, however, minor closure movements could be observed due to potential horizontal movements.

### 3.1.2 Movements Affecting Bridges

Because of the critical function of Bridge 2, and as for other bridges, RMS requires assessment of the effects of ground movements of magnitudes that have 1 in 100 and 1 in 2000 probability of exceedance due to mining. This is consistent with the limit state approach to bridge design (and checking) embodied in the Bridge Design Standard (AS5100). MSEC has therefore produced values for incremental relative opening, closing and mid-ordinate deviation at various probabilities, including 1 in 100 and 1 in 2000, to be applied to the bridge elements in both the longitudinal and transverse directions of the bridge for the assessment of potential effects on the bridge structure.

The following is a summary of the ground movement predictions for Bridge 2, derived from the MSEC report in Appendix F.

At Bridge 2, a distance of approximately 820 m from the closest point of the longwalls, the predicted subsidence parameters are less than survey tolerance, which is typically 20 mm for subsidence, 0.5 mm/m for tilt and  $0.01 \text{ km}^{-1}$  for curvature. The absolute horizontal movements measured at distances greater than 800 m are in the order of 45 mm based on the 95% confidence level.

Differential horizontal movements, which are most significant for the bridge structures, are difficult to predict since the potential values of relative movement are typically very small. For Bridge 2, there is the added complication that the spacing of bridge support elements varies from 5-18 m as compared to the commonly used spacing between survey points along monitoring lines of approximately 20 m.

Cawley Road Overpass is located at 1.44 km from Longwall 306 at its nearest point. At this distance, observed far-field movements from the Southern Coalfields database are close to nominal survey tolerance and observed differential horizontal movement data is predominantly within survey tolerance.

However, as for Bridge 2, Cawley Road Overpass needs to be assessed for low probability differential ground movements and MSEC has provided values for incremental relative opening, closing and mid-ordinate deviation at various probabilities of exceedance, including 1 in 100 and 1 in 2000, to be applied to the bridge elements for the assessment of potential effects.

## 3.2 Assessment of Ground Movement Impacts

### 3.2.1 Assessment of Impacts on M1 Motorway

The MSEC report in Appendix F included the following broad assessment of impacts on the M1 Motorway.

*The predicted conventional vertical subsidence for the M1 resulting from the extraction of LW301-303 is very small and the predicted tilts and curvatures are less than the expected limits of survey tolerance (i.e. 0.5 mm/m for tilt and  $0.01 \text{ km}^{-1}$  for curvature). Adverse impacts to the M1, including the road pavement,*

*slopes, culverts, barriers and furniture, resulting from conventional subsidence movements is considered unlikely.*

MSEC recommended that monitoring and management strategies are developed to manage the potential impacts on the M1, which would allow for the motorway to be maintained in a safe and serviceable condition.

As LW304-6 are further away from the M1 than the extractions of LW301-3, the adverse impacts on the M1 assets resulting from conventional subsidence movements is also considered unlikely.

### 3.2.2 Assessment of Bridges

A detailed quantitative assessment of the potential impacts of ground movements from Longwalls 301 to 303 on Bridge 2 (BN616/617) has been undertaken by the RMS Technical Committee. The Committee commissioned the bridge specialist on the committee (Cardno) to investigate and report on the potential effects on the bridge of the 1 in 100 and 1 in 2000 exceedance probability for differential ground movements. The report on that investigation was issued to the committee in May 2015. As ground movements of varying probability of exceedance were investigated, this is considered to be a detailed quantitative risk assessment.

In summary, the assessment found that the 1 in 100 probability differential ground movements could be tolerated by the structure with only relatively minor cracking as the worst consequence. It found that the 1 in 2000 probability differential ground movements could produce unacceptable effects including structural failure at some locations, if they occurred at disadvantageous locations. In this unlikely event, mining of the longwall may have to be terminated earlier than planned.

A similar detailed quantitative assessment of the effects of low probability differential ground movements on the Cawley Road Overpass was carried out. It found that the Cawley Road Overpass can tolerate the predicted ground movements up to the 1 in 2000 probability values.

As LW304-6 are further away from the bridges and overpass than the extractions of LW301-3 and that no differential ground movements have occurred in disadvantageous locations to date, it is considered unlikely that such movements will occur with the mining of LW304-6.

## 4 Risk Workshop

---

On 18 September 2018, a risk workshop was convened at the RMS Offices in Wollongong. The purpose of this workshop was to assess the risks posed to the assets of the RMS from this proposed longwall mining operation. A list of the participants at the workshop is included in Appendix B. The agenda is attached in Appendix C.

Peabody Energy provided an overview of the LW304-306 extraction area, an update on the mine activities and the current location and an update on the subsidence performance to date.

This workshop was qualitative, used the RMS look up sheets for assessing both frequency and consequence. These sheets have been adopted as the standard by the RMS when assessing the risk posed to their assets from mining subsidence. The look up sheets for assessing frequency, consequence, and the risk matrix are included in Appendix D.

The assets considered in the risk assessment included:

- Pavement;
- Bridges (Bridge 2; Cawley Road Overpass);
- Cuttings/Embankments;
- Drains/Culverts.

Subsidence management procedures considered in the risk assessment included:

- High Accuracy Fibre Optic Monitoring System;
- Conventional Survey/Visual Inspections;
- Management Measures; and
- Contingency Measures.

The workshop used the risk register from the LW301-303 study (which in turn considered the risk registers from the LW20-22 and LW23-27 studies) as the basis of discussion and reviewed each of the risks. For new items, a check-list of Assets and Fault/Failure modes was used to trigger thoughts and discussion. This information was recorded in the risk register, attached in Appendix A.

## 5 Results

A total of 18 risk events were identified during the workshop, of which 11 were not considered to present a credible risk (the level of possible impacts was not measurable). Additional mitigations were discussed for 10 risk events.

Following the RMS Risk Matrix (see Appendix D), risks are assessed as being Extreme (E), High (H), Moderate (M) or Low (L). Table 1 shows the number of entries in the risk register which were assessed in each category before and after additional mitigation measures are applied. It should be noted that all the suggested additional mitigations include monitoring, which does not change the risk ratings of the event.

Table 1: Risk Profile Before and After Implementation of Additional Mitigations

Receptor	Infrastructure				Functionality				Safety			
	E	H	M	L	E	H	M	L	E	H	M	L
Risk Level												
Base Risk Score	0	1	2	3	0	2	0	4	0	0	1	5
Final Risk Score	0	1	2	3	0	2	0	4	0	0	1	5

## 5.1 Carriageway

At over 820m from Longwalls 304 to 306, the RMS assets are not expected to experience measurable conventional vertical subsidence, tilts, curvatures or strains (i.e. no greater than survey accuracy). Impacts to the carriageway from conventional subsidence movements is considered unlikely to occur due to the extraction of Longwalls 304 to 306.

Visual inspections at the end of each panel would be appropriate to check for any cracks or deformations caused by the mining activities. RMS also performs drive-through checks during mining. A base line inspection needs to be recorded prior to commencement of mining.

## 5.2 Culverts

With valley closure movements less than 20 mm anticipated, there are unlikely to be anything more than minor impacts on the culverts.

For the culverts a pre-mining condition assessment using CCTV should be completed and any further inspections should be performed as per the Monitoring Plan. A culvert inspection is required upon completion of mining operations for LW303; this could form the baseline for monitoring during LW304-306 operations.

## 5.3 Cuttings

The cuttings were stabilised and rerated prior to the extraction of LW301-303. New risk ratings were provided in the Built Features Management Plan (July 2018); the risks were re-rated as part of the end of panel risk rating. Three changes to risk rankings were made:

- Cutting 10425: ARL2 to ARL3;
- Cutting 13560: ARL4 to ARL3; and
- Cutting 13562; ARL4 to ARL3.

The reratings were due to natural effects and were not related to mining LW301 to LW303.

The risk ratings at cuttings at Cawleys Road Overpass (CRO) are unchanged Assessed Risk Level 2 (ARL2), but are located approximately 1300 m from the start line of LW301.

For the cuttings, a survey is proposed at completion of each panel. Monitoring of the transmission lines will also provide early indications for the cuttings within the 20 mm subsidence contour. If the measurements exceed predicted levels, this will trigger a survey to be completed along the cuttings.

The regular RMS maintenance inspections are to include monitoring of rock fall.

## 5.4 Bridge and Overpass

Bridge 2 (BN616 southbound / BN617 northbound) have been setup to allow for monitoring of differential movements between key points on the structures. The monitoring provisions include installation of survey targets fixed at key points and FBG sensor cable to measure relative movement of key points at the tops of piers and abutments. The monitoring systems aim to detect distortion of the bridges which can then be assessed by Cardno to determine the effects on the structure.

The monitoring strategy for the Cawley Road Overpass (BN615) includes only the installation of survey targets fixed at key points. This aims to detect distortion of the bridges which can then be assessed by Cardno to determine the effects on the structure. If significant differential movements are detected, the frequency of monitoring can be increased to further understand the trend of movement.

The transmission line is also monitored by survey and this data can be used to predict potential impacts at the bridges. If significant relative movements are detected, then the frequency of monitoring at bridges should be increased to understand the trend of movement.

In addition, the transmission line is monitored by an array of GNSS stations (high accuracy GPS stations which monitor absolute movement). Movements monitored at these stations can be used to assess the need for increased monitoring at the bridges. The closest stations to the bridges are:

- GNSS03 within 150m of Bridge 2;
- GNSS09 within 150m of Cawley Road Overpass.

## 6 Conclusions

---

A risk assessment workshop was undertaken in order to understand the risks to RMS assets from the mining of longwalls LW304-306. The events and activities identified in the workshop will be addressed and managed in the Built Features Management Plan for LW304-306.

It is recommended that the existing monitoring of the assets is to continue and be adaptive to unexpected subsidence changes.

## Appendix A

### Risk Register

ID	ASSET	FAILURE TYPE	EVENT	Infra			Function			Safety			COMMENT	ADDITIONAL MITIGATION	Infra			Function			Safety			COMMENT
				F	C	R	F	C	R	F	C	R			F	C	R	F	C	R	F	C	R	
1	Carriageway	Cracking in the transverse direction	Build up of tensile stresses in the carriageway adjacent to LW301 causing cracks in the transverse direction.	E	1	L	E	1	L	E	1	L	Pavement cracks in the transverse direction (due to longitudinal strains) would not be extensive. Strains are expected to be tensile within the 20mm subsidence contour but would be of low order - approximately 0.4mm/m (95% confidence level). It is likely that multiple cracks will form that can be resolved by crack sealing. Extensive zones of compressive strains are not anticipated and with compressive stains of approximately 0.4mm/m (95% confidence level), no discernable impacts are anticipated.	End of Panel check visual inspection would be appropriate. Also continue RMS drive through check during mining. Base Line inspection after mining of LW303 needs to be recorded.  Using GNSS studies to verify predictions	E	1	L	E	1	L	E	1	L	
2		Cracking in longitudinal direction	Build up of tensile stresses in the carriageway causing cracks in the longitudinal direction.	E	1	L	E	1	L	E	1	L	Pavement cracks in the longitudinal direction (due to transverse strains) would not be extensive due to the limited width of pavement in the transverse direction. Strains are expected to be tensile within the 20mm subsidence contour but would be of low order - approximately 0.4mm/m (95% confidence level). Over a 12m carriage way width, the maximum single crack would be <5mm. More likely, multiple cracks of smaller widths will form that can be resolved by crack sealing. For compressive strains, no impacts are anticipated due to the 12m carriageway width.	End of Panel check visual inspection would be appropriate. Also continue RMS drive through check during mining. Base Line inspection after mining of LW303 needs to be recorded.  GNSS monitoring on the transmission line (early warning line) will provide early warning of movement anomalies	E	1	L	E	1	L	E	1	L	
3		Stepping	Rapid pavement failure, leading to hump or step										Not credible for the proposed longwalls.											
4		Deformations through geological structures and cut fill interfaces.	Structures to south of area at seam level.  Dyke at Cutting 13561.	E	2	L	E	2	L	E	2	L	Small deformations expected (humping and cracking). Can be detected through drive throughs and corrected as required.	End of Panel check visual inspection would be appropriate. Also continue RMS drive through check during mining. Base Line inspection needs to be recorded. <b>GNSS MONITORING WILL PROVIDE EARLY WARNING OF Potential MOVEMENTS</b>	E	2	L	E	2	L	E	2	L	Planned resurfacing by RMS should be delayed till after LW303 - Q1 2019 if condition allows. Survey required immediately before and after resurfacing if it happens.
5	Culvert	Culvert cracking due to mining movements	Culvert joints open, culvert damage (minor cracking)	E	3	M	E	1	L	E	1	L	If there is shearing movement, there should not be any issues. Probability of fault movement is very low as the mining is planned to not cause movement in the faults.  Most culverts are asbestos cement.  Pipes <500mm diameter, stresses would not cause a problem unless the pipes are already frail.	Premining condition assessment of culverts (using CCTV). Further inspections as per Monitoring Plan. Culvert inspection required as per RMS program at end of panel LW303. Particularly Cawleys Creek culvert and ones near Bridge 2.  GNSS will provide an early warning of movements that will indicate additional inspections may be required.	E	3	M	E	1	L	E	1	L	
6		Lose culvert grading	Ponding.									Not credible for the proposed longwalls.												
7	Kerb	Kerb/gutter cracking / buckling	Included as part of Pavement Assessment.									Not credible.												

**ROADS & MARITIME SERVICES**

**RISK ASSESSMENT - SUBSIDENCE IMPACTS ON RMS ASSETS FROM LONGWALLS LW304-306**

RISK REGISTER - 18 September 2018

DRAFT

REV A



ID	ASSET	FAILURE TYPE	EVENT	Infra			Function			Safety			COMMENT	ADDITIONAL MITIGATION	Infra			Function			Safety			COMMENT	
				F	C	R	F	C	R	F	C	R			F	C	R	F	C	R	F	C	R		
8	Cuttings	Excessive ground movement causing localised instability	Material falling onto the road. Remediation works already completed include grooming of slopes, shot-creting, fencing, rock netting and benching already completed. These treated slopes are in cuttings closest to LW301-303 and were re-rated by RMS in 10/16 as ARL4. The predicted movements are relatively minor - <50mm for subsidence and <20mm for valley closure, and these movements will not change the risk ratings for these slopes.	E	1	L							<p>Cuttings were stabilised and rerated prior to extraction of LW301-3. New risk ratings provided in BFMP and will be reassessed as part of end of panel risk rating. It is unlikely there will be any change in these risk ratings.</p> <p>Tensile cracking at the top of the cuttings could occur and this could cause water infiltration. However, the dyke is more likely to weather. Cuttings at Cawleys Road Overpass (CRO) – These cuttings are rated ARL2 (high risk), but are located ~1300m from the start line of LW301. Also, the Metropolitan Fault lies between LW301 and CRO, thereby forming a barrier to mining related movements at the cuttings.</p> <p>While movements of concern are not expected, these cuttings will be included in the monitoring proposed for CRO.</p> <p>Cuttings (2) south of LW301 – The nearer cutting rated ARL3 is ~870m from the LW301 finish line, and the other rated ARL2 is ~1120m from the LW301 finish line. While no discernible movements are expected at these cuttings from the mining of LW301-303, the cuttings will be monitored in accordance with Table 9 of the BFMP.</p>	<p>Survey monitoring at the completion of mining of each longwall. Monitoring of the transmission lines will provide early indications for the cuttings within the 20mm subsidence contour. If the measurements exceed predicted levels, this may trigger a survey to be completed along the cuttings.</p> <p>GNSS monitoring data will give early warning of any movements.</p> <p>Maintenance inspections to include monitoring of rock fall. Inspection will be carried out during the daytime network inspection which occurs at a frequency of once per week with the direction alternating.</p>	E	1	L								
9	Embankments	Excessive ground movement leading to localised slip failure	Cracks, water, instability.										These are flexible earth structures. Any issues are hypothetical. Not credible for the proposed longwalls.												
10	Furniture		Damage and serviceability issues.										Not credible for the proposed longwalls.												
11	Drains (above cuttings)		Damage to drains.										Not credible for the proposed longwalls.												
12	VMS	Excessive ground movement	Damage to the VMS.										Not credible for the proposed longwalls.												
13	Power lines (not an RMS asset) but may affect RMS assets	Tower / cable failure	Electrical hazard.										Not credible for the proposed longwalls due to the separation distances.												

ID	ASSET	FAILURE TYPE	EVENT	Infra			Function			Safety			COMMENT	ADDITIONAL MITIGATION	Infra			Function			Safety			COMMENT		
				F	C	R	F	C	R	F	C	R			F	C	R	F	C	R	F	C	R			
14		Distortion of bridge elements leading to inconsequential cracking (<0.1mm)	Differential movements between key points on the bridge of up to 5mm										The probability of occurrence of differential movement of this magnitude is as low as 1 in 10. No credible consequences.	Monitoring of differential movements between key points in structure from which effects on the bridge can be assessed. Monitoring systems includes surveying (to pick up 70% key points) and FBG sensor (to pick up 40-50% of key points, but much more accurate). If significant differential movements are detected, increase frequency of monitoring to understand the trend of movement.												
15	Bridge 2 (BN616 - southbound / 617 northbound)	Distortion of bridge elements leading to cracking that may require repair (between 0.1mm and 1.0mm)	Differential movements between key points on the bridge of 6mm to 15mm.	C	1	L	C	2	M	C	1	L	The probability of occurrence of differential movement of this magnitude is in the order of 1 in 100. Works to repair cracks will affect old Princes Hwy, not the M1.	As above. No economical mitigation measures to prevent the "failure" are possible.	C	1	L	C	2	M	C	1	L			
16		Distortion of bridge elements leading to development of wide cracks that would be considered as structural failure (>1.0mm)	Differential movements between key points on the bridge of 16mm to 44mm.	E	5	H	E	5	H	E	2	L	The probability of occurrence of differential movement of this magnitude is in the order of 1 in 2000. If differential movement is at a disadvantageous location, structural failure in the form of severe cracking could occur. This would be unacceptable, and the planned end-of-panel location must be brought forward to a position recommended by the Technical Committee well before differential movements reach this magnitude, for a termination of mining earlier than planned to avoid failure of the structure.	As above. No economical mitigation measures to prevent the "failure" are possible.	E	5	H	E	5	H	E	2	L			
17	Cawley Road Overpass (BN615)	Distortion of bridge elements leading to inconsequential cracking (<0.1mm)	Differential movements between key points on the bridge of up to 10mm.										The probability of occurrence of differential movement of this magnitude is as low as 1 in 10. No credible consequences.	Monitoring of differential movements between key points in structure from which effects on the bridge can be assessed. If significant differential movements are detected, increase frequency of monitoring to understand the trend of movement.												
18		Distortion of bridge elements leading to cracking that may require repair (between 0.1mm and 1.0mm)	Differential movements between key points on the bridge greater than 10mm and up to 20mm (the upper bound value).										The probability of occurrence of differential movement of this magnitude is in the order of 1 in 100 to 1 in 2000. No credible consequences.	As above.												

**ROADS & MARITIME SERVICES**

**RISK ASSESSMENT - SUBSIDENCE IMPACTS ON RMS ASSETS FROM LONGWALLS LW304-306**

RISK REGISTER - 18 September 2018

**DRAFT**

REV A



Transport  
Roads & Maritime  
Services



ID	ASSET	FAILURE TYPE	EVENT	Infra			Function			Safety			COMMENT	ADDITIONAL MITIGATION	Infra			Function			Safety			COMMENT	
				F	C	R	F	C	R	F	C	R			F	C	R	F	C	R	F	C	R		

**NOTE:**  
 RMS guidelines state a coverage zone of 5 times depth of mine (~2km).  
 All mitigation measures, regardless of the cell in which they are recorded, are deemed to apply to all risk events. Furthermore, control and mitigation measures listed in the report are also deemed to apply to all risk events in the risk register.

## **Appendix B**

### **Workshop Participants**

# ROADS & MARITIME SERVICES

## RISK ASSESSMENT - SUBSIDENCE IMPACTS ON RMS ASSETS

ATTENDANCE SHEET – 18 September 2018



Transport  
Roads & Maritime  
Services

Name	Position	Organisation
Matthew Brunton	Snr Project Manager	Monitor Optics Systems
Henk Buys	Geotech Engineer	AECOM
Richard Woods	Bridge Engineer	CARDNO
Felipe Palominos	Mining Engineer	Peabody.
Peter Debeno	Mine Subsidence Engineer	MSEC
DICK LEE SHOY	CHAIR, TECHNICAL COMMITTEE	RMS-CONSULTANT
JON DEGOTARDI	TECHNICAL SERVICES MANAGER	PEABODY
Donny Castro	Bridge Maintenance Planner	RMS
Vicki Temelkovski	A/Pavement Planner	RMS.

## Appendix C

### Workshop Agenda

## Meeting with Roads & Maritime Services [Technical Committee]

LW304-306 Extraction Plan – Built Features Management Plan  
M1 Princes Motorway

18 September 2018 – 1pm to 4:30pm  
Wollongong RMS Office - Level 4 Conference Room

# Agenda

### Purpose of meeting:

- To discuss the subsidence predictions relevant to LW304-306 prepared by MSEC
- Assess the risks relevant to LW301-303 for the Extraction Plan in accordance with the DP&E and DRE Draft *Guidelines for the Preparation of Extraction Plans*\*
- Review existing controls, procedures and programs and update if required for the LW304-306 BFMP.

Item	Detail	Who	Time:
	Introductions	Arup	1pm
1.	Update on mine activities and current location	Peabody	1:10pm
2.	Short overview of the LW304-306 extraction area		
3.	Subsidence predictions for LW304-306	MSEC	1:30
4.	Update on subsidence performance to date and inspections re: RMS assets (M1 Princes Motorway)	MSEC/Peabody	1:45
5.	Discussion on specific RMS assets including: <ul style="list-style-type: none"> <li>• Pavement</li> <li>• Bridges (Bridge 2; Cawley Road Overpass)</li> <li>• Cuttings/Embankments</li> <li>• Drains/Culverts</li> <li>• High Accuracy Fibre Optic Monitoring System</li> <li>• Conventional Survey/Visual Inspections</li> <li>• Management Measures</li> <li>• Contingency Measures</li> </ul>	Peabody/RMS/MSEC	2:15
6.	Risk assess any changes that may have bearing on the performance of the assets. Review existing controls, procedures and programs in existing BFMP (M1 Princes Motorway) for continued suitability and feasibility and update if required.	Peabody/RMS	3:30
7.	Next Steps <ul style="list-style-type: none"> <li>• Draft LW304-306 Register and Report</li> </ul>	Arup	4:00-4:30pm
		TOTAL	3.5 hrs

\*The Draft *Guidelines for the Preparation of Extraction Plans* require the BFMPs to include:

- the results of risk assessment conducted by a competent person in accordance with relevant standards and guidelines;
- description of the investigation and analysis methods used in determining the risk control measures and procedures, carried out by a competent person;
- description of all risk control measures and procedures, including a statement of the feasibility to manage identified risks; and
- a proposed program for implementation of the proposed risk control measures and procedures.

## **Appendix D**

### **Risk Criteria**

# ROADS & MARITIME SERVICES

## RISK ASSESSMENT - SUBSIDENCE IMPACTS ON RMS ASSETS

### FREQUENCY



Transport  
Roads & Maritime  
Services

Level	Descriptor	Alt. Description	Description	Chance %	Frequency
O	<b>Absolutely Certain</b>	Definite	This event will occur - known to occur now - <i>Will occur several (many) times each year and many times (constantly) during this project</i>	99.99	Several times each year
A	<b>Almost Certain</b>	Frequent	This event is expected to occur in most circumstances - <i>Expected to occur more than once during the duration of this project</i>	95	1 / year
B	<b>Likely</b>	Probable	This event will probably occur in most circumstances - <i>Expected to occur once during the duration of the project</i>	10	at least 1 / 10 years
C	<b>Possible</b>	Occasional	This event might (should) occur at some time - <i>Not likely to occur in life of project, but it is possible.</i>	1	at least 1 / 100 years
D	<b>Unlikely</b>	Remote	This event could occur at some time - <i>Unlikely (very) to occur in life of project</i>	0.1	at least 1 / 1,000 years
E	<b>Rare</b>	Very Unlikely	This event may occur in exceptional circumstances - <i>Examples of this have occurred historically, but it is not anticipated for this project</i>	0.01	at least 1 / 10,000 years
F	<b>Hypothetical</b>	Barely credible	Theoretically possible but never occurred to date (anywhere in the world) - <i>Often applied to natural events</i>	1.00E-03	every Million years

ARUP

**ROADS & MARITIME SERVICES**  
**RISK ASSESSMENT - SUBSIDENCE IMPACTS ON RMS ASSETS**  
**CONSEQUENCES**



Transport  
Roads & Maritime  
Services

Level	Descriptor	Infrastructure			Amenity			Safety / Societal Cost
		Pavement	Bridges	Cost	Access	Speed	Political	
1	Insignificant	Minor damage	Minor repairable damage	< \$50 k	Some loss in condition	No traffic effect	No political impact	No injuries or health effects
2	Minor	Noticeable damage	Damage that will deteriorate if not repaired quickly	< \$100 k	One lane closed for < half day. One planned lane closure < 1 day	Speed reduction for < 1 month - 80 kph	Minimal political impact (brief press coverage)	First aid treatment or minor damage to vehicles
3	Moderate	Significant damage	Significant damage	< \$1 Mk	One lane closed for < 1 day	Speed reduction for > 1 month - 80 kph or < 1 day - 40 kph	Political impact (press coverage)	Medical treatment required
4	Major	Extensive damage	Major damage - restricted speed	< \$10 M	One lane closed for > 1 day	Speed reduction for < 1 month - 40 kph	Significant political impact (extensive negative press coverage)	Extensive injuries or one or two permanent disabilities
5	Catastrophic	Loss of use of carriageway	Extensive damage. One carriageway closed until repaired	< \$50 M	One carriageway closed for > 1 day or both cways for < 2 day	Speed reduction for > 1 month - 40 kph	Major political impact (Commission of Enquiry)	Single fatality or severe permanent disabilities to several people
6	Untenable		Total failure of bridge or closed until repaired	> \$50 M	Both carriageways closed for > 2 day	Speed restrictions for > 12 months - 40 kph		Multiple fatalities

**ROADS & MARITIME SERVICES**  
**RISK ASSESSMENT - SUBSIDENCE IMPACTS ON RMS ASSETS**  
**RISK MATRIX**



LIKELIHOOD		CONSEQUENCES					
		1 (Insignificant)	2 (Minor)	3 (Moderate)	4 (Major)	5 (Catastrophic)	6 (Unthinkable)
Multiple	O	H	E	E	E	E	E
Almost Certain	A	H	H	E	E	E	E
Likely	B	M	H	H	E	E	E
Possible	C	L	M	H	E	E	E
Unlikely	D	L	L	M	H	E	E
Rare	E	L	L	M	H	H	E
Hypothetical	F	L	L	L	M	H	H

<b>Low</b>	Low risk; managed by routine procedures.
<b>Moderate</b>	Moderate risk; requires above normal attention.
<b>High</b>	High risk; ALARP must be applied.
<b>Extreme</b>	Extreme risk; not acceptable and must be reduced.

## Appendix E

### Peabody BFMP Presentation



Metropolitan Coal  
Longwalls 304-306  
Built Features Management Plan  
Roads & Maritime Services

---

Jon Degotardi  
Technical Services Manager

September, 2018

**Peabody**



DELIVERING  
**RESULTS**  
GENERATING  
**VALUE**





Peabody's  
Metropolitan Mine

---

▼

# Metropolitan Colliery Location



# Extraction Plan Components

- **Built Features Management Plan(s)**
  - Roads and Maritime Services
- Water Management Plan
- Biodiversity Management Plan
- Land Management Plan
- Heritage Management Plan
- Public Safety Management Plan
- Subsidence Monitoring Program

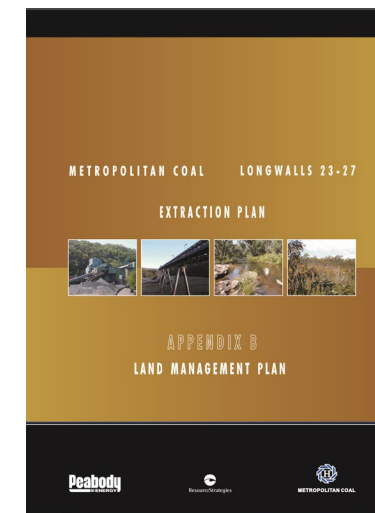
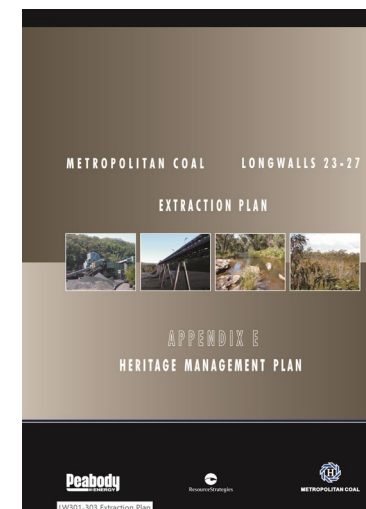
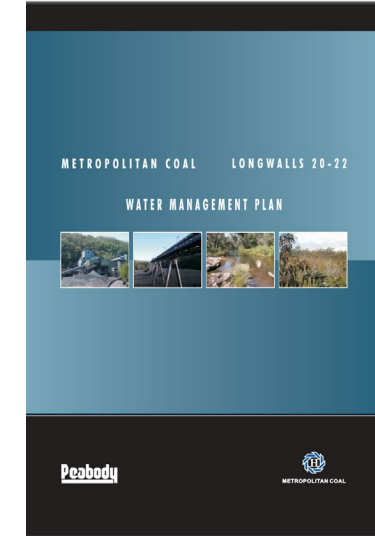
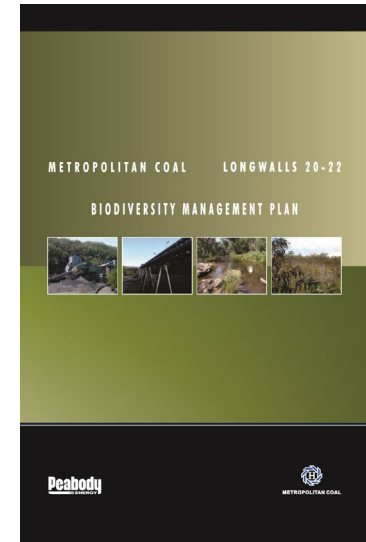

## LW304-306 Extraction Plan

---

### Project Approval Condition

- The subsidence impact performance measure specified in Table 1 of Condition 1, Schedule 3 in relation to built features is:

***Safe, serviceable and repairable, unless the owner and the MSB agree otherwise in writing.***

# LW304-306 Extraction Plan Changes to Mine Layout

- 2,675m reduction in extraction length (~1/3 reduction). Planned lengths are:
  - LW304 – 1,438m
  - LW305 – 2,055m
  - LW306 – 2,933m
- Consolidation of the panel and chain pillar widths of Longwalls 304-306 to 163 m panel widths (void) and 45 m wide pillars (solid)
- Subject to approval from DP&E

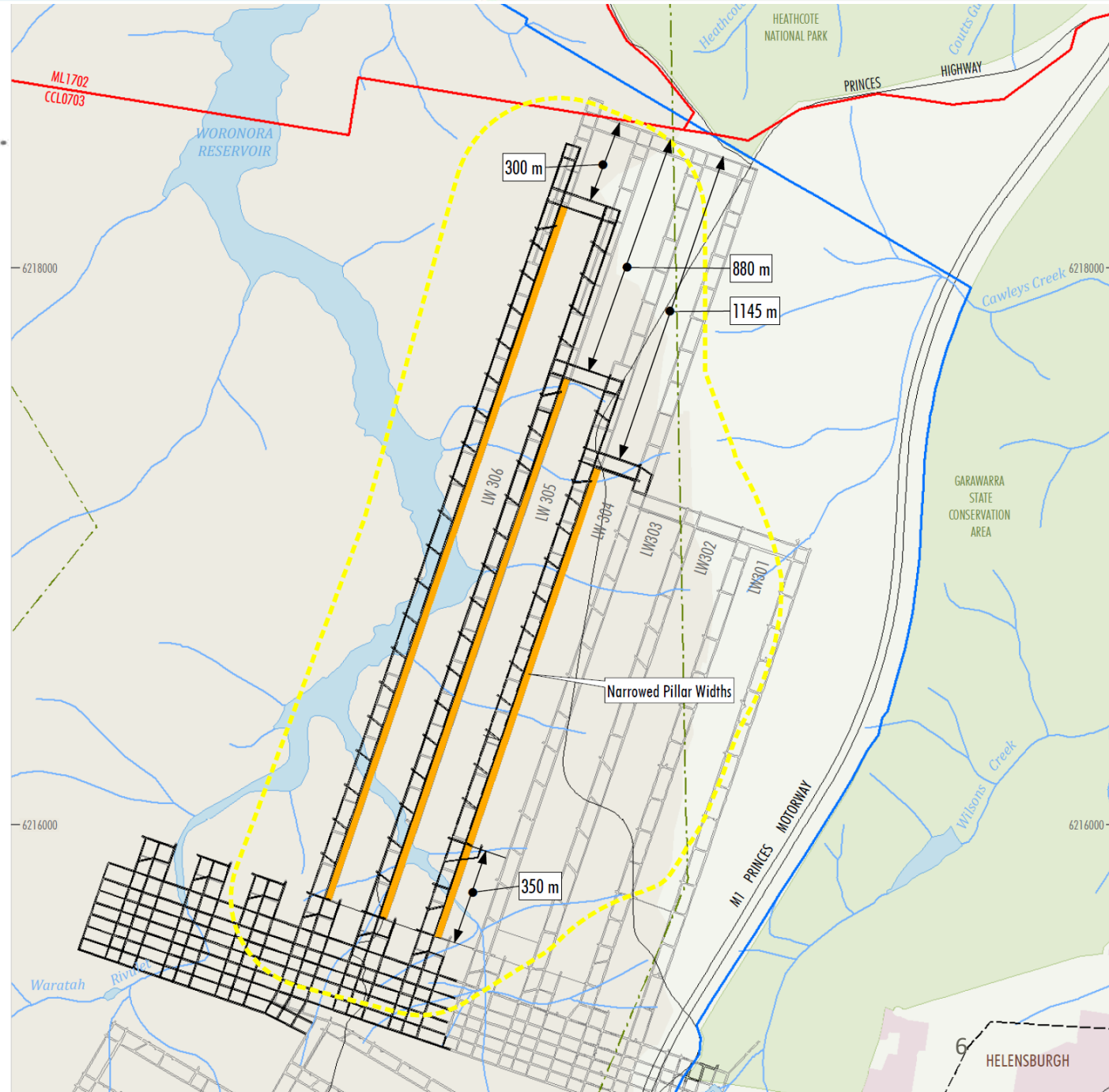

# LW304-306 Extraction Plan

## Key Distances

- Extraction area moving away from M1 Motorway
- Pavement, Cuttings, Embankments, Culverts (>0.8km)
- Bridge 2 (>0.8km)
- Cawley Bridge (>1.4 km)

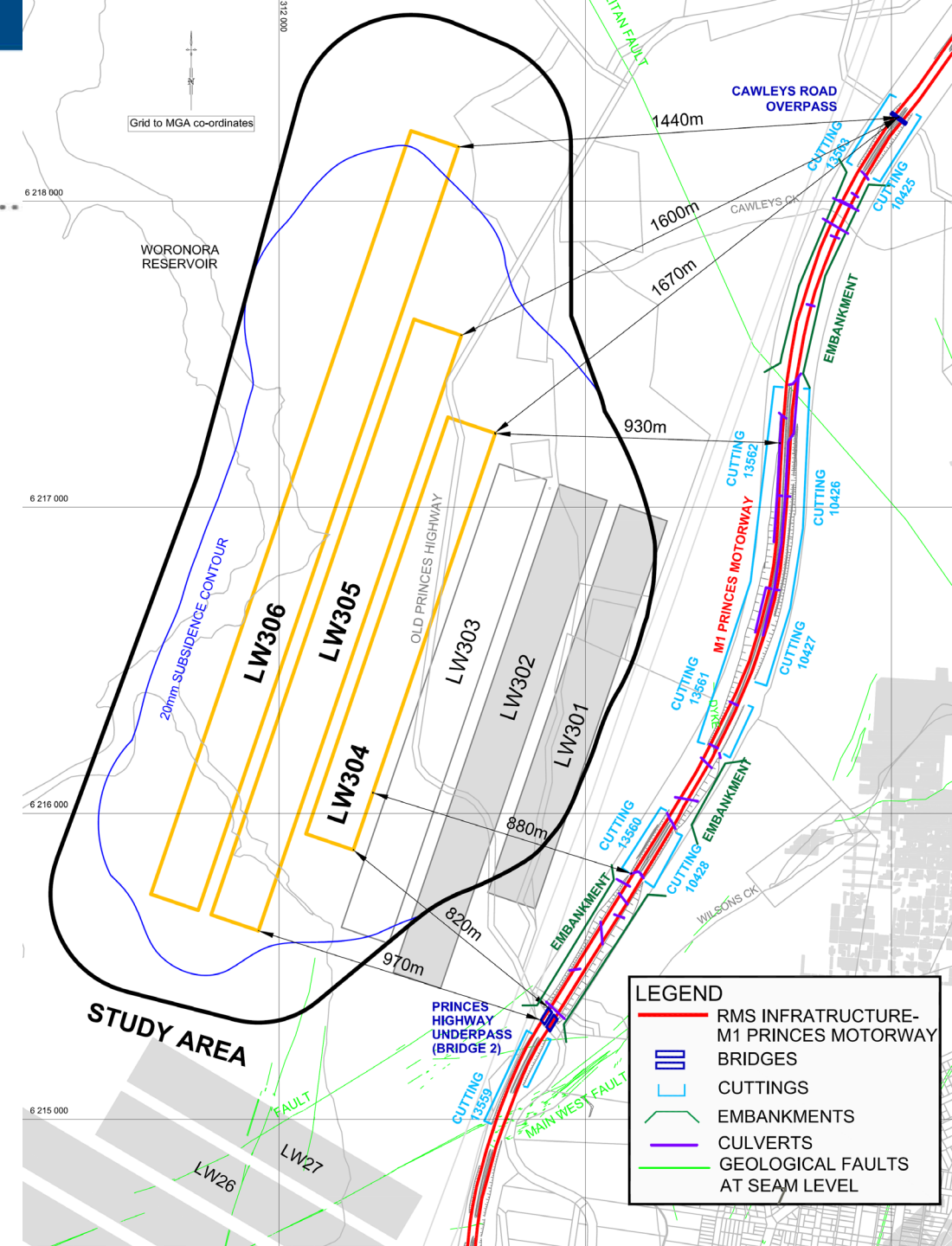

# LW304-306 Extraction Plan Monitoring Program

Maintain LW301-303 regime as a minimum

- GNSS real time units
- Traditional survey
- FBG on Bridge 2

Cardno (NSW/ACT)

Underpass 2 - FBG Monitoring  
X and Y Relative Movements

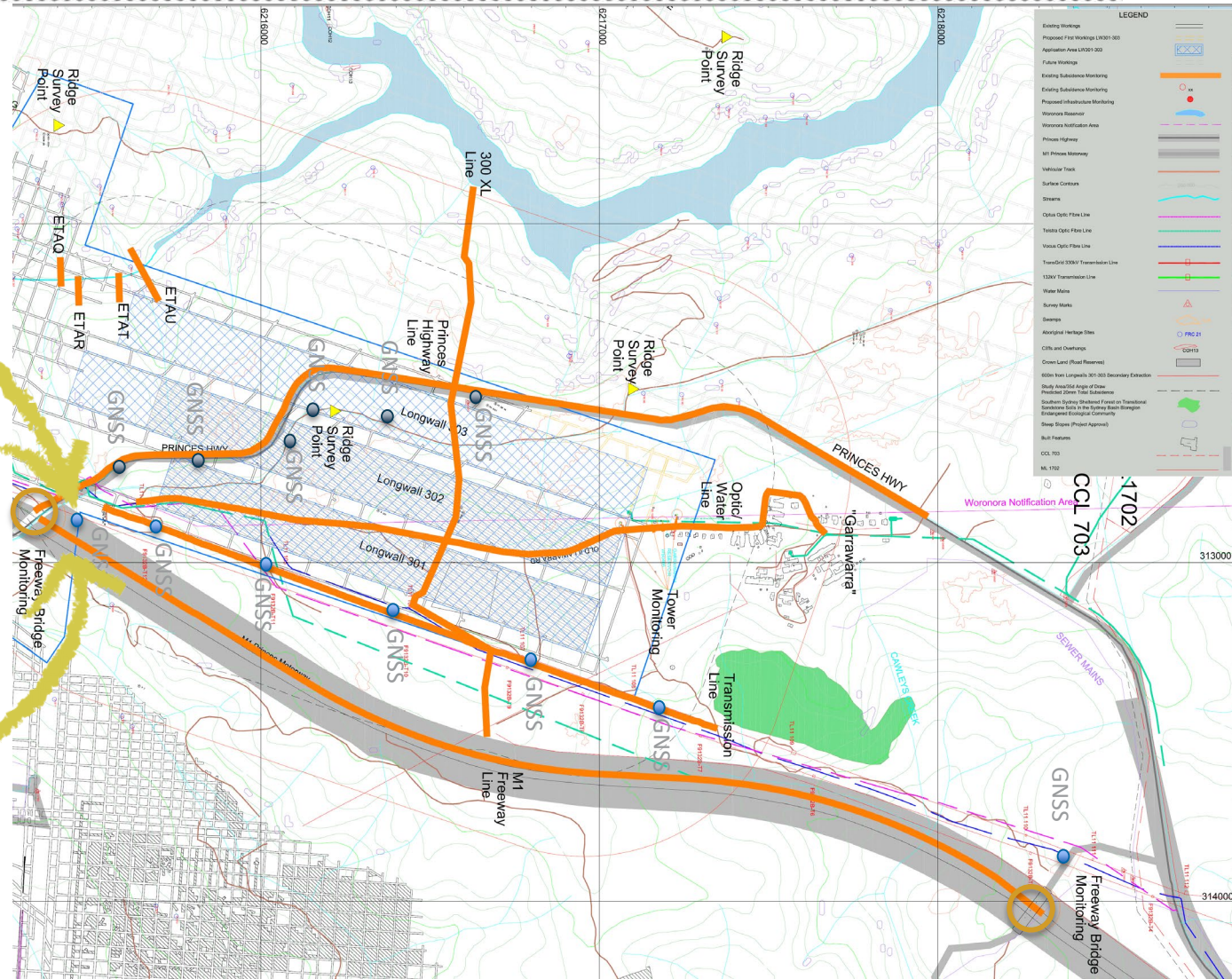
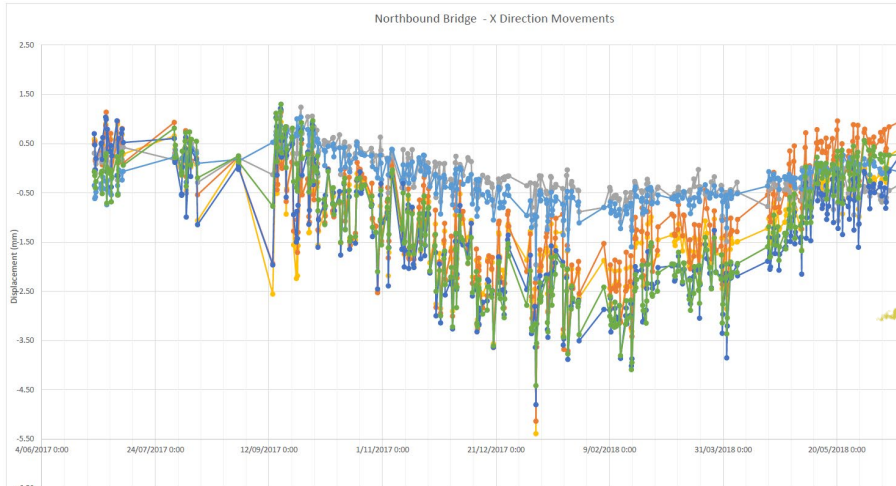

# LW304-306 Extraction Plan

## Geological Features

- Geological features relevant to M1 Motorway
- Structures include;
  - Metropolitan Fault (north-east),
  - dyke with surface exposure in cutting, and
  - other mapped faults (south-east).
- No changes to mapped features in vicinity of M1 Motorway since 2016 assessment for LW301-303.

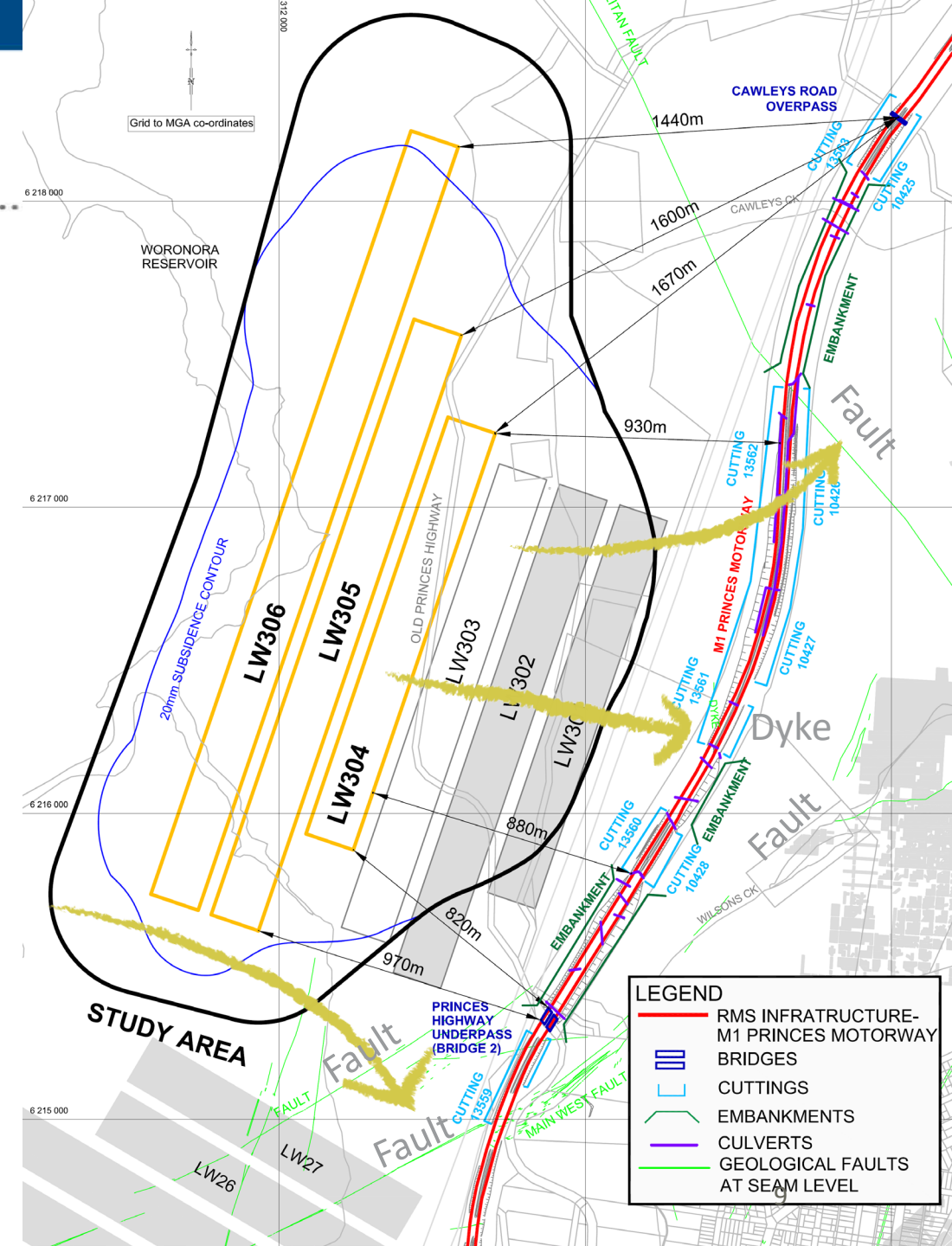

# LW304-306

## Subsidence Predictions



## **Appendix F**

### **MSEC Subsidence Report**

6<sup>th</sup> September 2016

Jon Degotardi  
Peabody Energy Australia  
Metropolitan Colliery  
PO Box 402  
Helensburgh NSW 2508

Ref: MSEC844-08

Dear Jon,

**RE: Metropolitan Colliery – Proposed Longwalls 301 to 303 - Subsidence Predictions and Impact Assessments for the Roads and Maritime Services Infrastructure**

This letter report summarises the predicted subsidence movements and the assessed subsidence impacts for the Roads and Maritime Services (RMS) infrastructure resulting from the extraction of the proposed Longwalls 301 to 303 at Metropolitan Colliery.

The locations of the RMS infrastructure and the proposed longwalls are shown in the attached Drawing No. MSEC844-08. The M1 Princes Motorway is located to the east of Longwalls 301 to 303. The distance of the M1 Princes Motorway from Longwalls 301 to 303 varies from 210 metres near the finishing (southern) end of Longwall 301 to 335 metres near the commencing (northern) end of Longwall 301.

A series of cuttings and embankments up to a maximum height of approximately 20 metres are shown in the attached Drawing No. MSEC844-08. A summary of the rock cuttings is provided in Table 1.

**Table 1 Summary of RMS Rock Cuttings**

RMS Slope Number	RMS Assessed Risk Level (ARL)	Length (m)	Maximum Slope Height (m)	Average Slope Angle (degrees)
13563	2	202	17	65
13562	2	531	18	70
13561	2	599	13	62
13560	2	231	8	70
10425	2	188	9	66
10426	2	503	15	55
10427	2	452	14	55
10428	2	192	9	65

A bridge is located at the crossing of the M1 Princes Motorway with the Old Princes Highway (Bridge 2), and is located approximately 330 metres from Longwall 301. The next nearest bridge is Cawley Road Overpass, which is located approximately 1.43 kilometres to the north east of Longwall 303.

A series of culverts cross the M1 Princes Motorway, as shown on Drawing No. MSEC844-08. The culverts comprise pipes of varying diameters from 375 mm to 1800 mm. The pipe materials comprise asbestos cement (pipes up to

600 mm diameter) and steel reinforced concrete (pipes up to 1800 mm diameter). In addition to the culverts, there are also a number of other drainage structures, such as kerbs, gutters, pits and drainage pipes. The largest culvert comprises two 1800mm pipes located to the north east of the longwalls at Cawley's Creek.

The predictions and impact assessments for the RMS infrastructure are provided in the following sections.

### Conventional Subsidence Parameters for the RMS Infrastructure

A summary of the maximum predicted values of total subsidence, tilt and curvature for the M1 Princes Motorway, resulting from the extraction of Longwalls 301 to 303, is provided in Table 2. The values are the maxima anywhere along the section of the motorway located within the Study Area.

**Table 2 Predicted Total Subsidence, Tilt and Curvature for the M1 Princes Motorway Resulting from the Extraction of Longwalls 301 to 303**

Longwall	Maximum Predicted Total Conventional Subsidence (mm)	Maximum Predicted Total Conventional Tilt (mm/m)	Maximum Predicted Total Conventional Hogging Curvature (km <sup>-1</sup> )	Maximum Predicted Total Conventional Sagging Curvature (km <sup>-1</sup> )
After LW301	< 20	< 0.5	< 0.01	< 0.01
After LW302	50	< 0.5	< 0.01	< 0.01
After LW303	50	< 0.5	< 0.01	< 0.01

The maximum predicted conventional tilt and curvature are negligible and less than typical limits of survey accuracy (i.e. 0.5 mm/m for tilt and 0.01 km<sup>-1</sup> for curvature).

Princes Motorway will potentially experience low level far-field horizontal movement. The far-field horizontal movements are expected to be similar to those observed for previous longwall mining in the Southern Coalfield.

The observed incremental far-field horizontal movements, resulting from the extraction of longwalls in the Southern Coalfield, are provided in Figure 1. The data are based on survey marks located outside of the mining area (i.e. above solid coal).

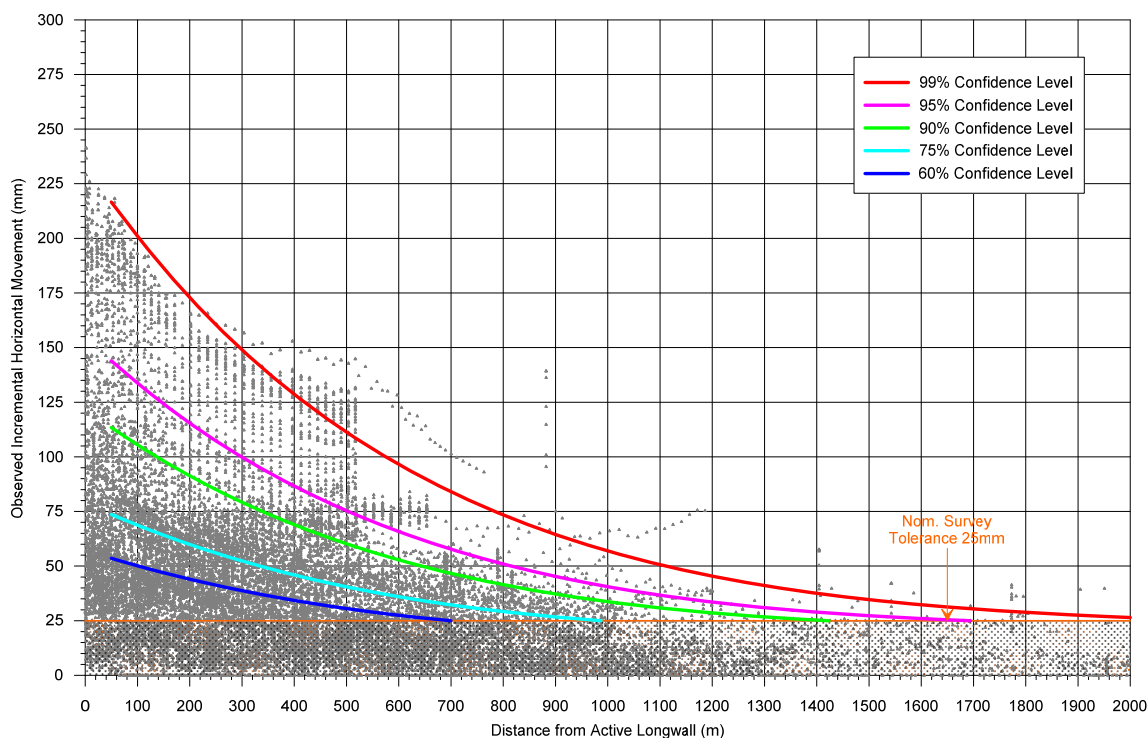

**Figure 1 Observed Incremental Far-field Horizontal Movements from the Southern Coalfield (Solid Coal)**

The absolute horizontal movements measured at distances greater than 210 metres from mining are in the order of 115 mm based on the 95 % confidence level. These low level movements comprise a large proportion of survey tolerance. Far-field horizontal movements tend to be bodily movements orientated towards the mining area. The strains associated with these low level horizontal movement are not expected to be measurable.

### **Predicted Strains**

The prediction of strain is more difficult than the predictions of subsidence and tilt. The reason for this is that strain is affected by many factors, including ground curvature and horizontal movement, as well as local variations in the near surface geology, the locations of pre-existing natural joints at bedrock and the depth of bedrock. Survey tolerance can also represent a substantial portion of the measured strain, in cases where the strains are of a low order of magnitude. The profiles of observed strain, therefore, can be irregular even when the profiles of observed subsidence, tilt and curvature are relatively smooth.

In previous MSEC subsidence reports, predictions of conventional strain were provided based on the best estimate of the average relationship between curvature and strain. Similar relationships have been proposed by other authors. The reliability of the strain predictions was highlighted in these reports, where it was stated that measured strains can vary considerably from the predicted conventional values.

Adopting a linear relationship between curvature and strain provides a reasonable prediction for the conventional tensile and compressive strains. In the Southern Coalfield, it has been found that a factor of 15 provides a reasonable relationship between the predicted maximum curvatures and the predicted maximum conventional strains. The locations that are predicted to experience hogging or convex curvature are expected to be net tensile strain zones and locations that are predicted to experience sagging or concave curvature are expected to be net compressive strain zones.

At a point however, there can be considerable variation from the linear relationship, resulting from non-conventional movements or from the normal scatters which are observed in strain profiles. When expressed as a percentage, observed strains can be many times greater than the predicted conventional strain for low magnitudes of curvature. We have therefore provided a statistical approach to account for the variability, instead of just providing a single predicted conventional strain.

The range of predicted strains for the RMS infrastructure has been determined using the monitoring data from Metropolitan Colliery and other nearby collieries. The data used in the analysis of observed strains included those resulting from both conventional and non-conventional anomalous movements, but did not include those resulting from valley related movements. The strains resulting from damaged or disturbed survey marks have also been excluded.

The M1 Princes Motorway is located at distances of 200 metres or greater from the longwalls. The database of measured strains has therefore been analysed to extract the maximum tensile and compressive strains that have been measured at any time during the extraction of the previous longwalls in the Southern Coalfield, for survey bays that were located outside and within 100 metres to 250 metres of the nearest longwall goaf edge, which has been referred to as "*above solid coal*".

A histogram of the maximum observed tensile and compressive strains measured in survey bays located above solid coal, for monitoring lines in the Southern Coalfield, is provided in Figure 2. The probability distribution functions, based on a fitted *Generalised Pareto Distribution (GPD)*, have also been shown in this figure.

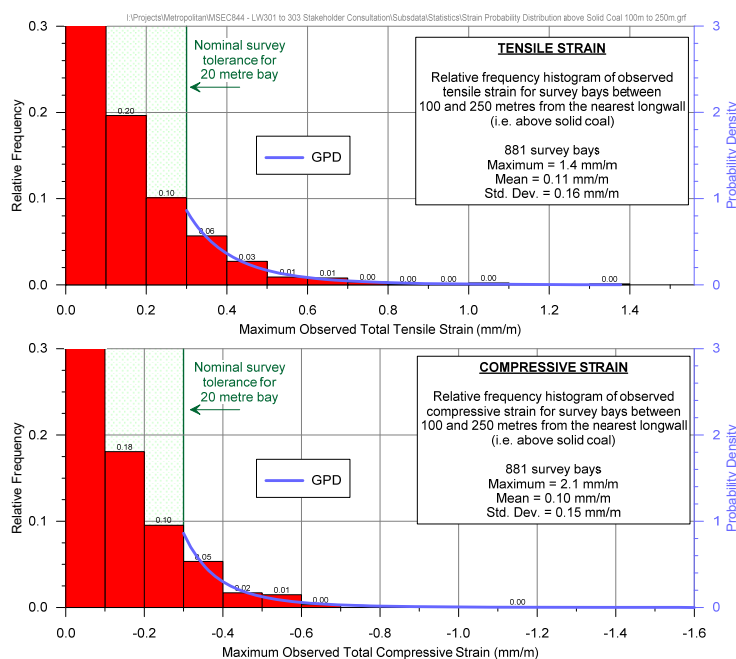

**Figure 2 Distributions of the Measured Maximum Tensile and Compressive Strains during the Extraction of Previous Longwalls in the Southern Coalfield Above Solid Coal (100 to 250 metres)**

Confidence intervals have been determined from the empirical strain data using the fitted GPDs. In the cases where survey bays were measured multiple times during a longwall extraction, the maximum tensile strain and the maximum compressive strain were used in the analysis (i.e. single tensile strain and single compressive strain measurement per survey bay).

A summary of the probabilities of exceedance for tensile and compressive strains for survey bays located above solid coal, based on the fitted GPDs, is provided in Table 3.

**Table 3 Probabilities of Exceedance for Strain for Survey Bays Located above Solid Coal**

Strain (mm/m)		Probability of Exceedance
Compression	-2.0	1 in 9,840
	-1.5	1 in 3000
	-1.0	1 in 635
	-0.5	1 in 55
	-0.3	1 in 10
Tension	+0.3	1 in 9
	+0.5	1 in 36
	+1.0	1 in 410
	+1.5	1 in 2,200
	+2.0	1 in 8,000

The 95 % confidence intervals for the maximum total strains that the individual survey bays above solid coal (100 to 250 metres) experienced at any time during mining are 0.4 mm/m tensile and compressive. The 99 % confidence intervals for the maximum total strains that the individual survey bays above solid coal experienced at any time during mining are 0.7 mm/m tensile and 0.6 mm/m compressive.

## Potential for Non-Conventional Movements

Non-conventional movements can develop due to the presence of geological structures or valley related effects. In some cases, non-conventional movements can develop with no known cause and these are often referred to as 'anomalous' movements.

The locations of the known geological structures and the streams are shown in Drawing No. MSEC844-08.

There are no identified geological structures above the longwalls. The M1 Princes Motorway crosses the Metropolitan Fault approximately 500 metres to the north east of Longwall 301 and several faults to the south east of Longwalls 301 and 302 intersecting the M1 Princes Motorway at approximately 340 metres. The absolute horizontal movements measured at distances of 500 metres and 340 metres from mining are in the order of 75 mm and 95 mm respectively based on the 95 % confidence level. It is noted that these faults are identified at seam level and surface expression of faults may occur at different locations, or faults may not have continuity to the ground surface.

A drainage line crosses the M1 Princes Motorway approximately 210 metres east of the finishing end of Longwall 301, as shown on Drawing No. MSEC844-08. Predicted valley closure across the culvert at the location of the M1 Princes Motorway is less than 20 mm.

A second drainage line is located to the north of the longwalls at Cawley's Creek. Due to the shortened commencing end of the longwalls, the culvert is located approximately 1060 metres from the nearest longwall (Longwall 301). At this distance, the culvert is not predicted to experience valley related movements due to the extraction of the Longwalls 301 to 303.

Valley closure is not expected to occur in the cuttings along the M1 Princes Motorway, however, minor closure movements could be observed due to potential horizontal movements.

## Impact Assessments for the M1 Princes Motorway

The predicted conventional vertical subsidence for the M1 Prince Motorway resulting from the extraction of Longwalls 301 to 303 are very small and the predicted tilts and curvatures are less than the expected limits of survey tolerance. Adverse impacts to the M1 Princes Motorway, including the road pavement, slopes, culverts, barriers and furniture, resulting from conventional subsidence movements is considered unlikely.

The M1 Princes Motorway will potentially experience far-field horizontal movements resulting from the extraction of the Longwalls 301 to 303 of up to 115 mm, based on the 95% confidence level.

There are no major geological features to the east of the longwalls near the M1 Princes Motorway. The mapped geological features are shown on Drawing No. MSEC846-08. The Metropolitan Fault intersects the M1 Princes Motorway at approximately 500 metres to the north east of Longwall 301. There are mapped faults to the south east of Longwalls 301 and 302, intersecting the M1 Princes Motorway at approximately 340 metres from the longwalls. A dyke with a surface exposure is also present to the east of Longwall 301 at approximately 380 metres from Longwall 301. There is the potential for far-field horizontal movements to result in the minor differential movement near the faults and potential shearing and/or stepping in the road pavement. The faults have been mapped at seam level and surface expressions have not been identified. The mapped dyke has been identified in the motorway cuttings. There is also the potential for far-field horizontal movements to result in differential movement at the interface of cut and fill areas along the motorway corridor.

The M1 Princes Motorway crosses a valley and an associated drainage culvert to the east of the Longwall 301 finishing end. The predicted valley closure due to Longwalls 301 to 303 is less than 20 mm. A second valley and culvert are located at Cawley's Creek, approximately 930 metres from Longwall 303. Adverse impacts to the culverts resulting from conventional subsidence and valley related movements is considered unlikely.

It is recommended that monitoring and management strategies are developed, in consultation with RMS, to manage the potential impacts on the M1 Princes Motorway. It is expected that the motorway can be maintained in safe and serviceable conditions with the implementation of the appropriate monitoring and management strategies.

## Impact Assessments for the Bridges

An assessment of Bridge 2 (RMS reference BN616-southbound and BN617-northbound) has been undertaken by the RMS technical committee, which was formed prior to the commencement of the extraction of Longwall 20 to assess and monitor potential impacts to RMS assets due to the extraction of longwalls at Metropolitan Colliery. A letter report MSEC696-02 dated 30<sup>th</sup> June 2014 was prepared based on a preliminary layout of Longwalls 301 to 317. The distance of the bridge from the longwalls is unchanged at 330 metres hence the impact assessments are the same as previously reported. A summary of the subsidence predictions and impact assessments for Bridge 2 is provided below.

- At a distance of approximately 330 metres, the predicted subsidence parameters are less than survey tolerance, which is typically 20mm for subsidence, 0.5mm/m for tilt and 0.01km<sup>-1</sup> for curvature. The predicted conventional subsidence parameters indicate that with high accuracy survey, minor subsidence, tilt and hogging curvature may be observed, but sagging curvature is unlikely to be observed.
- The absolute horizontal movements measured at distances greater than 330 metres are in the order of 95 mm based on the 95% confidence level. An absolute horizontal movement of 105 mm based on the 95% confidence level was provided in the MSEC696-02 report. The updated data set as presented in Figure 1 results in a slightly lower value of observed horizontal movement, however the difference of 10 mm does not change the impact assessments for the bridge.
- It is difficult to predict differential horizontal movements since the potential values of relative movement are typically very small and much of the scatter in the observed data is the result of survey accuracy. Also, a spacing between pegs of 20 metres is commonly used along monitoring lines, and this distance is larger than the typical column and blade wall spacing for Bridge 2.
- Differential horizontal movement was assessed by analysing the far-field horizontal movement data discussed above. The data set was analysed to determine incremental relative opening and closing and incremental mid ordinate deviation.
- The incremental relative opening and closing and mid ordinate deviation for various probabilities at a distance of approximately 330 metres from an active longwall are summarised in Table 4 and Table 5.

**Table 4 Incremental Relative Opening, Closing and Mid-Ordinate Deviation at Approximately 330 metres Distance from Active Longwall**

	1 in 20 probability (95% confidence level)	1 in 100 probability (99% confidence level)	1 in 2000 probability (99.95% confidence level)
Opening	8 mm	14 mm	44 mm
Closing	6 mm	13 mm	44 mm
Mid-Ordinate Deviation	9 mm	15 mm	32 mm

**Table 5 Incremental Relative Opening, Closing and Mid-Ordinate Deviation due to First Panel Extraction Only**

	1 in 20 probability (95% confidence level)	1 in 100 probability (99% confidence level)	1 in 2000 probability (99.95% confidence level)
Opening	5 mm	10 mm	25 mm
Closing	4 mm	9 mm	32 mm
Mid Ordinate Deviation	5 mm	8 mm	14 mm

- The differential movements presented in Table 4 and Table 5 should be applied to the bridge elements in both the longitudinal and transverse direction of the bridge. The application of the differential movements to short bridge element spacing (e.g. columns approximately 5m apart), was discussed by the technical committee and it was agreed that the movements should be applied directly to shorter element spacing.
- The differential longitudinal movement, opening (+ve) and closing (-ve) should be applied to the longitudinal and transverse direction as an opening and closing movement, between piers, and between columns. The mid-ordinate deviation should be applied to an out of plane movement of one pier relative to adjacent piers, which are spaced at 13.5 metres at abutments and 18.3 metres in the centre, as well as between columns which are approximately 5 metres apart.
- Faults have been identified at seam level to the west and to the east of Bridge 2. The nearest faults, Main West and Powel are approximately 235 metres horizontal distance from Bridge 2. There are no mapped surface expressions of the faults. The projected alignments of these faults do not intersect the location of Bridge 2. There is a low likelihood of the identified structures directly impacting Bridge 2, however other potential unidentified structures may be present at or near the bridge location.

A decision was made by the RMS technical committee to monitor potential movements of Bridge 2 using a high accuracy fibre optic monitoring system, along with conventional surveying methods. The monitoring system is being established to record baseline readings during the extraction of Longwalls 26 and 27, prior to the commencement of Longwall 301.

Cawley Road Overpass is located at 1.43 kilometres from Longwall 301 at its nearest point. At this distance, observed far-field movements as shown in Figure 1 are close to nominal survey tolerance and observed differential movement data is predominantly within survey tolerance. Differential horizontal movement was assessed by analysing the far-field horizontal movement data. The data set was analysed to determine incremental relative opening and closing and incremental mid ordinate deviation at a distance of approximately 1.43 kilometres from an active longwall.

The incremental relative opening and closing and mid ordinate deviation for various probabilities at a distance of approximately 1.43 kilometres from an active longwall are summarised in Table 6.

**Table 6 Incremental Relative Opening, Closing and Mid-Ordinate Deviation at Approximately 1.43 kilometres Distance from Active Longwall**

	1 in 20 probability (95% confidence level)	1 in 100 probability (99% confidence level)	1 in 2000 probability (99.95% confidence level)
Opening	4 mm	7 mm	14 mm
Closing	5 mm	9 mm	19 mm
Mid-Ordinate Deviation	7 mm	10 mm	18 mm

At this distance, adverse impact to Cawley Road Overpass resulting from the extraction of Longwalls 301 to 303 is considered unlikely, however an assessment of the structure should be undertaken to assess the sensitivity of the structure to potential differential movements a result of Longwalls 301 to 303.

## Summary

The M1 Princes Motorway is located greater than 210 metres to the east of Longwalls 301 to 303. The previous experience from the Southern Coalfield has found that the potential impacts on bitumen seal and asphaltic pavements can be managed with the implementation of suitable monitoring and management strategies.

It is recommended that monitoring and management strategies are developed, in consultation with RMS, to manage the potential impacts on the M1 Princes Motorway. It is expected that the motorway can be maintained in safe and serviceable conditions with the implementation of the appropriate monitoring and management strategies.

Bridge 2 is located approximately 330 metres from Longwall 301. A program of high accuracy monitoring of this bridge has been implemented by the RMS technical committee and will be outlined in the Built Features Management Plan for Longwalls 301 to 303. The culverts and Cawley Road Overpass are located outside the predicted 20 mm subsidence contour. Whilst these features could experience low level far-field horizontal movements, they are not expected to experience measurable strains or differential horizontal movements. Assessment of these structures should be undertaken by the RMS technical committee to assess the sensitivity of these structures to potential differential movements a result of Longwalls 301 to 303.

Yours sincerely

Peter DeBono

Mine Subsidence Engineering Consultants

Attachments:

Drawing No. MSEC844-08 – Longwalls 301 to 303 – RMS Infrastructure



Suite 402, 13 Spring Street, Chatswood NSW 2067  
 PO Box 302, Chatswood NSW 2057  
 Tel +61 2 9413 3777  
 www.minesubsidence.com



**METROPOLITAN COAL**  
 METROPOLITAN COLLIERY  
 LONGWALLS 301 TO 303  
 RMS

DATE: 23 Aug 2016	SCALE: 1:12500	DRAWING No: MSEC844-08	Rev No A
----------------------	-------------------	---------------------------	-------------

6 218 000

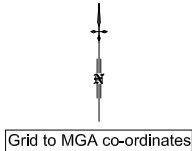

WORONORA RESERVOIR

6 217 000

6 216 000

6 215 000

313 000

314 000

CAWLEY ROAD OVERPASS

METROPOLITAN FAULT

CAWLEYS CK

STUDY AREA

1430m

EMBANKMENT

20mm SUBSIDENCE CONTOUR

OLD PRINCES HIGHWAY

LW303

LW302

LW301

CUTTING 13562

M1 PRINCES MOTORWAY

CUTTING 10426

CUTTING 13561

CUTTING 10427

EMBANKMENT

CUTTING 13560

CUTTING 10428

WILSONS CK

330m

PRINCES HIGHWAY UNDERPASS (BRIDGE 2)

FAULT

MAIN WEST FAULT

POWELL FAULT

**LEGEND**

- RMS INFRASTRUCTURE- M1 PRINCES MOTORWAY
- BRIDGES
- CUTTINGS
- EMBANKMENTS
- CULVERTS
- GEOLOGICAL FAULTS AT SEAM LEVEL

APPENDIX 7

METROPOLITAN COLLIERY LONGWALL MINING – LW 305-307 RISK ASSESSMENT AS  
APPLIED TO RMS ASSETS

Metropolitan Coal – LW305-307 Built Features Management Plan – Roads and Maritime Services		
Revision No. BFMP_TFNSW-R01-D		
Document ID: Built Features Management Plan - TFNSW		

Roads & Maritime Services

**Metropolitan Colliery Longwall  
Mining – LW305-307**

**Risk Assessment as Applied to RMS  
Assets**

264172/REP/002

| 2 October 2019

This report takes into account the particular instructions and requirements of our client.

It is not intended for and should not be relied upon by any third party and no responsibility is undertaken to any third party.

Job number 264172-00

Arup  
Arup Pty Ltd ABN 18 000 966 165



**Arup**  
Level 17  
1 Nicholson Street  
East Melbourne VIC 3002  
Australia  
[www.arup.com](http://www.arup.com)

**ARUP**

# Document Verification

# ARUP

<b>Job title</b>		Metropolitan Colliery Longwall Mining – LW305-307		<b>Job number</b>		264172-00	
<b>Document title</b>		Risk Assessment as Applied to RMS Assets		<b>File reference</b>			
<b>Document ref</b>		264172/REP/002					
<b>Revision</b>	<b>Date</b>	<b>Filename</b>	20190828 RMS LW305-307 Report				
Draft 1	28 Aug 2019	<b>Description</b>	First draft				
			Prepared by	Checked by	Approved by		
		<b>Name</b>	Jas Calder-Lowndes	Ben Smith	Nigel Cann		
		<b>Signature</b>					
Issue 1	2 Oct 2019	<b>Filename</b>	20191002 RMS LW305-307 Report				
		<b>Description</b>	First draft				
			Prepared by	Checked by	Approved by		
		<b>Name</b>	Jas Calder-Lowndes	Ben Smith	Nigel Cann		
							
		<b>Signature</b>					
			Prepared by	Checked by	Approved by		
		<b>Name</b>					
		<b>Signature</b>					

Issue Document Verification with Document



## Contents

---

	Page	
<b>1</b>	<b>Introduction</b>	<b>1</b>
<b>2</b>	<b>Description of Proposed Mining</b>	<b>1</b>
<b>3</b>	<b>RMS Assets Affected</b>	<b>3</b>
	3.1 Predicted Ground Movements	3
	3.2 Assessment of Ground Movement Impacts	5
<b>4</b>	<b>Risk Workshop</b>	<b>6</b>
<b>5</b>	<b>Results</b>	<b>7</b>
	5.1 Carriageway	7
	5.2 Culverts	7
	5.3 Cuttings	8
	5.4 Bridge and Overpass	8
<b>6</b>	<b>Conclusions</b>	<b>9</b>

## Appendices

### Appendix A

Risk Register

### Appendix B

Workshop Participants

### Appendix C

Workshop Agenda

### Appendix D

Risk Criteria

### Appendix E

Peabody BFMP Presentation

### Appendix F

MSEC Subsidence Report

## 1 Introduction

---

Arup has been engaged by Roads & Maritime Services (RMS) to undertake a risk assessment with regards to the impacts on RMS assets arising from subsidence due to the mining of longwalls LW305-307 in the Metropolitan Mine which is owned by a subsidiary of Peabody Energy (Peabody).

Previous risk assessments were completed in 2009, 2013, 2016 and 2018 on the impacts of subsidence from LW20-22, LW23-27, LW301-303 and LW304-06 respectively. A history of the impacts of subsidence has been gained, along with knowledge about the performance of mitigation control measures applied and the reliability of the monitoring systems utilised.

As with the previous assessments, the concern of RMS is the possible impacts from the mining of LW305-307 on its surface assets with a specific emphasis on how the mining might result in financial loss to RMS, loss of functionality of the assets with regards to the road users (motorists and public) and possible life safety issues, should the mining adversely impact on any of the assets.

The process adopted by Arup follows closely the principles set out in AS/NZS ISO31000:2009 – Risk Management, and the various standards of RMS, specifically those relating to the assessment of risks posed by subsidence mining.

Arup facilitated a workshop with relevant stakeholders to firstly identify the assets at risk and then ascertain the risks posed to those assets from the mining of LW305-307. This same workshop also considered various mitigation and control measures and determined the effectiveness of these in reducing risk levels.

The events and activities identified in the workshop will be addressed and managed in the Built Features Management Plan for LW305-307.

## 2 Description of Proposed Mining

---

Peabody, or Metropolitan Colliery (MC), proposes to extract longwalls LW305-307 as part of its ongoing underground coal mining operations within the Bulli Seam at the Metropolitan Mine. The mine is located in the Southern Coalfield of New South Wales. The overall layout of longwalls LW305-307 is shown in Figure 1.

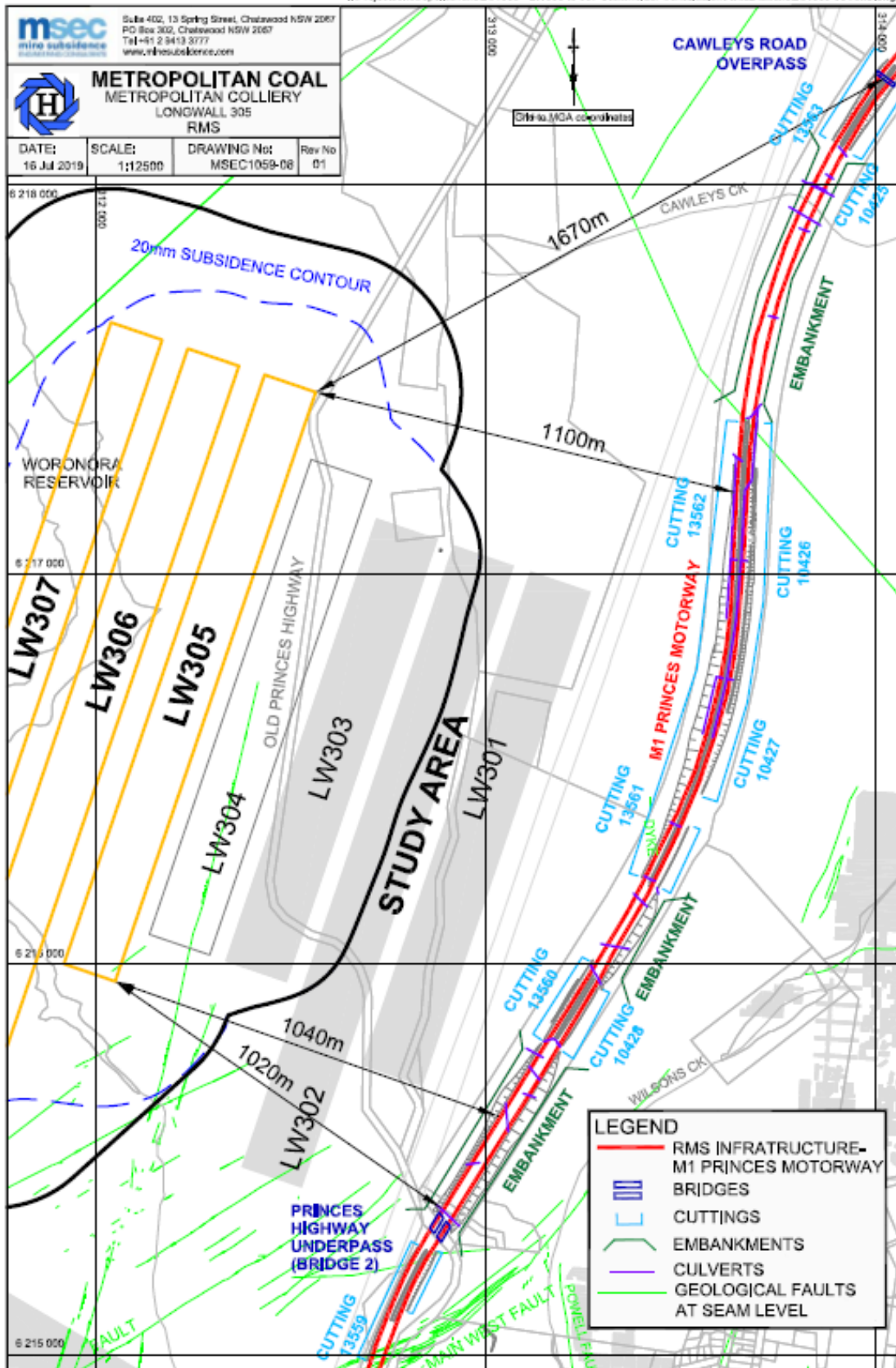

Figure 1: Layout of LW305-307

## 3 RMS Assets Affected

---

Figure 1 shows the extent of the proposed mining in relation to the RMS assets located along the Princes Motorway.

The RMS guidelines [Ref 1] define the zone of interest for infrastructure impacts as being five times the depth of cover. With a depth of cover of approximately 400 m, the zone of interest extends some 2 km from the longwalls.

The M1 Princes Motorway is located to the east of LW305-307. The distance of the M1 from LW305-307 varies from 1040 m near the finishing (southern) end of LW305 to 1100 m near the commencing (northern) end of LW305.

There are a series of cuttings and embankments up to a maximum height of approximately 20 m along the M1.

There are two bridges (BN616/617- shown as Bridge 2 in Figure 1) carrying the northbound and southbound traffic on the M1 Princes Motorway over the old Princes Highway and these are located approximately 1020 m from the southern end of LW305. The next nearest bridge is Cawley Road Overpass (BN615), which is located approximately 1.67 km to the east of LW305, at its nearest point to the mining.

A series of culverts of varying diameters from 375 mm to 1800 mm cross the M1 Princes Motorway. A number of the culverts are asbestos cement pipes. In addition to the culverts, there are also a number of other drainage structures, such as kerbs, gutters, pits and drainage pipes. The largest culvert comprises two 1800 mm pipes located to the north east of the longwalls at Cawley's Creek.

It should be noted the two large culverts and Cawley Road Overpass are located well outside the predicted 20 mm subsidence contour.

### 3.1 Predicted Ground Movements

Mine Subsidence Engineering Consultants Pty Ltd (MSEC) presented their predictions of ground movements for RMS assets from the mining of LW305-307, and a broad assessment of impact on the assets in a report which is included as Appendix F.

#### 3.1.1 Movements Affecting the M1 Motorway

The following is a summary of the ground movement predictions for the M1 Motorway:

- As with LW301-3 and LW304-06, the maximum predicted conventional tilt and curvature are less than the expected limits of survey accuracy (i.e. 0.5 mm/m for tilt and 0.01 km<sup>-1</sup> for curvature).
- The M1 will potentially experience far-field horizontal movements of up to 45 mm, based on a 95% confidence level, from a database of observed far-field horizontal movements in the Southern Coalfield.

- Similarly, from the Southern Coalfields survey database, the 95% confidence intervals for the maximum total strains that the individual survey bays above solid coal (100-250 m) experienced at any time during mining are 0.4mm/m tensile and compressive.
- Predicted valley closure across the culvert to the east of the finishing end of Longwall 304 is less than 20 mm.
- Valley closure is not expected to occur in the cuttings along the M1, however, minor closure movements could be observed due to potential horizontal movements.

### 3.1.2 Movements Affecting Bridges

Because of the critical function of Bridge 2, and as for other bridges, RMS requires assessment of the effects of ground movements of magnitudes that have 1 in 100 and 1 in 2000 probability of exceedance due to mining. This is consistent with the limit state approach to bridge design (and checking) embodied in the Bridge Design Standard (AS5100). MSEC has therefore produced values for incremental relative opening, closing and mid-ordinate deviation at various probabilities, including 1 in 100 and 1 in 2000, to be applied to the bridge elements in both the longitudinal and transverse directions of the bridge for the assessment of potential effects on the bridge structure.

The following is a summary of the ground movement predictions for Bridge 2, derived from the MSEC report in Appendix F.

At Bridge 2, a distance of approximately 1020 m from the closest point of the longwalls, the predicted subsidence parameters are less than survey tolerance, which is typically 20 mm for subsidence, 0.5 mm/m for tilt and 0.01 km<sup>-1</sup> for curvature. The absolute horizontal movements measured at distances greater than 800 m are in the order of 45 mm based on the 95% confidence level.

Differential horizontal movements, which are most significant for the bridge structures, are difficult to predict since the potential values of relative movement are typically very small. For Bridge 2, there is the added complication that the spacing of bridge support elements varies from 5-18m m as compared to the commonly used spacing between survey points along monitoring lines of approximately 20 m.

Cawley Road Overpass is located at 1.67 km from Longwall 305 at its nearest point. At this distance, observed far-field movements from the Southern Coalfields database are close to nominal survey tolerance and observed differential horizontal movement data is predominantly within survey tolerance.

However, as for Bridge 2, Cawley Road Overpass needs to be assessed for low probability differential ground movements and MSEC has provided values for incremental relative opening, closing and mid-ordinate deviation at various probabilities of exceedance, including 1 in 100 and 1 in 2000, to be applied to the bridge elements for the assessment of potential effects.

## 3.2 Assessment of Ground Movement Impacts

### 3.2.1 Assessment of Impacts on M1 Motorway

The MSEC report in Appendix F included the following broad assessment of impacts on the M1 Motorway.

*The motorway (including bridges and associated features) is not expected to experience measurable conventional vertical subsidence, tilt, curvature and strain. The M1 Princes Motorway could experience far-field horizontal movements resulting from the extraction of the Longwall 305 of up to 40mm, based on the 95% confidence level for observed far-field horizontal movement data for the Southern Coalfield. The observed horizontal movements are however, expected to be less than these values. Observed horizontal movements have been recorded at several real time GNSS<sup>1</sup> monitoring units located to the east of Longwalls 301 and 303. The observations to date show a maximum observed incremental horizontal movement of 15mm at 1km from an active longwall.*

*Adverse impacts to the M1 Princes Motorway, including the road pavement, slopes, culverts, barriers and furniture, resulting from conventional subsidence movements is considered unlikely to occur due to the extraction of Longwall 305 to 307.*

MSEC recommended that monitoring and management strategies are developed to manage the potential impacts on the M1, which would allow for the motorway to be maintained in a safe and serviceable condition.

As LW305-7 are further away from the M1 than the extractions of LW301-4, the adverse impacts on the M1 assets resulting from conventional subsidence movements is also considered unlikely.

### 3.2.2 Assessment of Bridges

A detailed quantitative assessment of the potential impacts of ground movements from Longwalls 305 to 307 on Bridge 2 (BN616/617) has been undertaken by the RMS Technical Committee. The Committee commissioned the bridge specialist on the committee (Cardno) to investigate and report on the potential effects on the bridge of the 1 in 100 and 1 in 2000 exceedance probability for differential ground movements. The report on that investigation was issued to the committee in May 2015. As ground movements of varying probability of exceedance were investigated, this is considered to be a detailed quantitative risk assessment.

In summary, the assessment found that the 1 in 100 probability differential ground movements could be tolerated by the structure with only relatively minor cracking as the worst consequence. It found that the 1 in 2000 probability differential ground movements could produce unacceptable effects including structural failure at some locations, if they occurred at disadvantageous locations. In this unlikely event, mining of the longwall may have to be terminated earlier than planned.

---

<sup>1</sup> Global Navigation Satellite System

A similar detailed quantitative assessment of the effects of low probability differential ground movements on the Cawley Road Overpass was carried out. It found that the Cawley Road Overpass can tolerate the predicted ground movements up to the 1 in 2000 probability values.

As LW305-7 are further away from the bridges and overpass than the extractions of LW301-4, and no differential ground movements have occurred in disadvantageous locations to date, it is considered unlikely that such movements will occur with the mining of LW305-7.

## 4 Risk Workshop

---

On 20 August 2019, a risk workshop was convened at the RMS Offices in Wollongong. The purpose of this workshop was to assess the risks posed to the assets of the RMS from this proposed longwall mining operation. A list of the participants at the workshop is included in Appendix B. The agenda is attached in Appendix C.

Peabody Energy provided an overview of the LW305-307 extraction area, an update on the mine activities and the current location and an update on the subsidence performance to date.

This workshop was qualitative, using the RMS look up sheets for assessing both frequency and consequence. These sheets have been adopted as the standard by the RMS when assessing the risk posed to their assets from mining subsidence. The look up sheets for assessing frequency, consequence, and the risk matrix are included in Appendix D.

The assets considered in the risk assessment included:

- Pavement;
- Bridges (Bridge 2; Cawley Road Overpass);
- Cuttings/Embankments;
- Drains/Culverts.

Subsidence management procedures considered in the risk assessment included:

- High Accuracy Fibre Optic Monitoring System;
- High accuracy GPS stations (GNSS units);
- Conventional Survey/Visual Inspections;
- Management Measures; and
- Contingency Measures.

The workshop used the risk register from the LW304-306 study (which in turn considered the risk registers from the LW301-03, LW20-22 and LW23-27 studies) as the basis of discussion and reviewed each of the risks. For new items, a check-list of Assets and Fault/Failure modes was used to trigger thoughts and discussion. This information was recorded in the risk register, attached in Appendix A.

## 5 Results

A total of 18 risk events were identified during the workshop, of which 11 were not considered to present a credible risk (the level of possible impacts was not measurable). Additional mitigations were discussed for 10 risk events.

Following the RMS Risk Matrix (see Appendix D), risks are assessed as being Extreme (E), High (H), Moderate (M) or Low (L). Table 1 shows the number of entries in the risk register which were assessed in each category before and after additional mitigation measures are applied. It should be noted that all the suggested additional mitigations include monitoring, which does not change the risk ratings of the event.

Table 1: Risk Profile Before and After Implementation of Additional Mitigations

Receptor	Infrastructure				Functionality				Safety			
	E	H	M	L	E	H	M	L	E	H	M	L
Risk Level												
Base Risk Score	0	1	1	5	0	1	1	4	0	0	0	6
Final Risk Score	0	1	1	5	0	1	0	5	0	0	0	6

### 5.1 Carriageway

At over 1040 m from Longwall 305, the RMS assets are not expected to experience measurable conventional vertical subsidence, tilts, curvatures or strains (i.e. no greater than survey accuracy). Impacts to the carriageway from conventional subsidence movements is considered unlikely to occur due to the extraction of Longwalls 305 to 307.

GNSS is now the primary source of data for movement to check for cracks or deformations caused by the mining activities. There has been negligible movement to date. End of panel surveys will continue as comparative conditions assessments. The study area now only includes the area north of Bridge 2.

There have been no movements due to geological structures recorded to date, and geological structures are unlikely to impact the pavement for LW305 to LW307. The consequence rating has been reduced as the impact of this failure type is lower.

### 5.2 Culverts

With valley closure movements anticipated to be less than 20 mm, any impact on the culverts is expected to be minor.

A pre-mining condition assessment should be performed on the culverts using CCTV and any further inspections should be performed as per the Monitoring Plan. A culvert inspection is required upon completion of mining operations for LW304; this could form the baseline for monitoring during LW305-307 operations.

GNSS will provide an early warning of movements that will indicate additional inspections may be required.

The driving force or the consequence rating is the cost of culvert repair, as the pipework contains asbestos. The next planned inspection will occur after LW307.

### 5.3 Cuttings

The cuttings were stabilised and re-rated prior to the extraction of LW301-303. New risk ratings were provided in the Built Features Management Plan (July 2018); the risks were re-rated as part of the end of panel risk rating. It is unlikely there will be any change in these risk ratings.

The risk ratings at cuttings at Cawleys Road Overpass (CRO) are unchanged at Assessed Risk Level 2 (ARL2) although these cuttings are located approximately 1600 m from the start line of LW305. The closest absolute movement monitoring point (GNSS09) indicates that no mining-related movement has occurred at the cutting.

A survey (cross cutting) of the cuttings is proposed at completion of each panel. GNSS monitoring of the transmission lines will also provide early indications of movement of the cuttings within the 20 mm subsidence contour. Measurements exceeding predicted levels will trigger the requirement for a survey to be completed along the cuttings from the mining of LW305-07.

The regular RMS maintenance inspections will include monitoring of rock fall.

No changes in cutting conditions are predicted. The survey monitoring program will continue at the end of panels through to LW307. At the end of LW307 the cuttings are to be risk rated in accordance with the RMS guide.

### 5.4 Bridge and Overpass

Bridge 2 (BN616 southbound / BN617 northbound) has been set up such that monitoring of differential movements can occur between key points on the structures. The monitoring provisions include the installation of survey targets fixed at key points and fibre Bragg grating (FBG) sensor cables to measure the relative movement of key points at the top of piers and abutments. The monitoring systems are designed to detect distortion of the bridges which can then be assessed by Cardno to determine the effects on the structure.

There has been no significant change detected to date. FBG monitoring will continue at the same frequency and will be reported quarterly. Bridge inspections will be performed at the end of LW304 and LW307. The Bridge 2 terrestrial survey is to be completed at the end of each longwall.

The estimated frequency of distortion of bridge elements occurring and leading to cracking of between 0.1 mm and 1.0 mm, requiring repair, has been reduced (compared to the assessment for LW304-6) in the risk register to “D” (unlikely) based on experience to date.

Similarly, the estimated frequency of distortion of bridge elements occurring and leading to creaking of more than 1.0 mm is lower than for LW304-6, but is still assessed as “E” (rare) rather than being reduced to “F” (hypothetical).

The monitoring strategy to identify relative movements at the Cawley Road Overpass (BN615) includes only the installation of survey targets fixed at key points. This aims to identify distortion of the bridges which can then be assessed by Cardno to determine the effects on the structure. If significant differential movements are detected, the frequency of monitoring can be increased to further understand the trend of movement.

The transmission line survey has essentially been replaced by the installation of GNSS units to measure absolute movements. Movements monitored at the GNSS stations will be used to assess the need for increased monitoring at the bridges. The closest stations to the bridges are:

- GNSS03 within 150m of Bridge 2;
- GNSS09 within 150m of Cawley Road Overpass.

GNSS09 has reported no movement to date. End of panel surveys will be discontinued unless appreciable movement at GNSS09 is recorded (>30 mm). A final confirmatory survey of bridge prisms will occur at the end of the longwall that reaches a distance of 5 times the depth cover from Cawleys Road Overpass.

## 6 Conclusions

---

A risk assessment workshop was undertaken in order to understand the risks to RMS assets from the mining of longwalls LW305-307. The events and activities identified in the workshop will be addressed and managed in the Built Features Management Plan for LW305-307.

It is recommended that the existing monitoring and management of mine subsidence impacts on RMS assets should continue, including being adaptive to unexpected subsidence changes.

## Appendix A

### Risk Register

**ROADS & MARITIME SERVICES**

**RISK ASSESSMENT - SUBSIDENCE IMPACTS ON RMS ASSETS FROM LONGWALLS LW305-307**

RISK REGISTER - 20 August 2019

ISSUE

REV A



Transport  
Roads & Maritime  
Services



ID	ASSET	FAILURE TYPE	EVENT	Infra			Function			Safety			COMMENT	ADDITIONAL MITIGATION	Infra			Function			Safety			COMMENT
				F	C	R	F	C	R	F	C	R			F	C	R	F	C	R	F	C	R	
1	Carriageway	Cracking in the transverse direction	Build up of tensile stresses in the carriageway adjacent to LW301 causing cracks in the transverse direction.	E	1	L	E	1	L	E	1	L	Pavement cracks in the transverse direction (due to longitudinal strains) would not be extensive. Strains are expected to be tensile within the 20mm subsidence contour but would be of low order - approximately 0.4mm/m (95% confidence level). It is likely that multiple cracks will form that can be resolved by crack sealing. Extensive zones of compressive strains are not anticipated and with compressive stains of approximately 0.4mm/m (95% confidence level), no discernable impacts are anticipated.	End of Panel check visual inspection would be appropriate. Also continue RMS drive through check during mining. Base Line inspection after mining of LW303 needs to be recorded.  Using GNSS studies to verify predictions	E	1	L	E	1	L	E	1	L	GNSS is now the primary source of data for movements. Amount of movement is negligible to date. Risk levels have not changed. End of panel surveys will continue as comparative condition assessment. Study area now only north of Bridge 2.
2		Cracking in longitudinal direction	Build up of tensile stresses in the carriageway causing cracks in the longitudinal direction.	E	1	L	E	1	L	E	1	L	Pavement cracks in the longitudinal direction (due to transverse strains) would not be extensive due to the limited width of pavement in the transverse direction. Strains are expected to be tensile within the 20mm subsidence contour but would be of low order - approximately 0.4mm/m (95% confidence level). Over a 12m carriage way width, the maximum single crack would be <5mm. More likely, multiple cracks of smaller widths will form that can be resolved by crack sealing. For compressive strains, no impacts are anticipated due to the 12m carriageway width.	End of Panel check visual inspection would be appropriate. Also continue RMS drive through check during mining. Base Line inspection after mining of LW303 needs to be recorded.  GNSS monitoring on the transmission line (early warning line) will provide early warning of movement anomalies	E	1	L	E	1	L	E	1	L	As above
3		Stepping	Rapid pavement failure, leading to hump or step											Not credible for the proposed longwalls.										
4		Deformations through geological structures and cut fill interfaces.	Structures to south of area at seam level.  Dyke at Cutting 13561.	E	2	L	E	2	L	E	2	L	Small deformations expected (humping and cracking). Can be detected through drive throughs and corrected as required.	End of Panel check visual inspection would be appropriate. Also continue RMS drive through check during mining. Base Line inspection needs to be recorded.  GNSS monitoring will provide early warning of potential movements	E	1	L	E	1	L	E	1	L	No movements related to geological features have been recorded. Unlikely these will occur for remaining longwalls. Consequence rating been reduced as impact of this failure type is reduced.
5	Culvert	Culvert cracking due to mining movements	Culvert joints open, culvert damage (minor cracking)	E	3	M	E	1	L	E	1	L	If there is shearing movement, there should not be any issues. Probability of fault movement is very low as the mining is planned to not cause movement in the faults.  Most culverts are asbestos cement.  Pipes <500mm diameter, stresses would not cause a problem unless the pipes are already frail.	Premining condition assessment of culverts (using CCTV). Further inspections as per Monitoring Plan.  Culvert inspection required as per RMS program at end of panel LW304. Particularly Cawleys Creek culvert and ones near Bridge 2.  GNSS will provide an early warning of movements that will indicate additional inspections may be required.	E	3	M	E	1	L	E	1	L	Cost of culvert repair is driving the consequence rating (Asbestos containing pipework). Next inspection after LW307
6		Lose culvert grading	Ponding.											Not credible for the proposed longwalls.										
7	Kerb	Kerb/gutter cracking / buckling	Included as part of Pavement Assessment.										Not credible.											

**ROADS & MARITIME SERVICES**

**RISK ASSESSMENT - SUBSIDENCE IMPACTS ON RMS ASSETS FROM LONGWALLS LW305-307**

RISK REGISTER - 20 August 2019

ISSUE

REV A



Transport  
Roads & Maritime  
Services



ID	ASSET	FAILURE TYPE	EVENT	Infra			Function			Safety			COMMENT	ADDITIONAL MITIGATION	Infra			Function			Safety			COMMENT					
				F	C	R	F	C	R	F	C	R			F	C	R	F	C	R	F	C	R						
8	Cuttings	Excessive ground movement causing localised instability	Material falling onto the road. Remediation works already completed include grooming of slopes, shot-creting, fencing, rock netting and benching already completed. These treated slopes are in cuttings closest to LW301-303 and were re-rated by RMS in 10/16 as ARL4. The predicted movements are relatively minor - <50mm for subsidence and <20mm for valley closure, and these movements will not change the risk ratings for these slopes.	E	1	L							<p>Cuttings were stabilised and rerated prior to extraction of LW301-3. New risk ratings provided in BFMP and will be reassessed as part of end of panel risk rating. It is unlikely there will be any change in these risk ratings.</p> <p>Tensile cracking at the top of the cuttings could occur and this could cause water infiltration. However, the dyke is more likely to weather.</p> <p>Cuttings at Cawleys Road Overpass (CRO) – These cuttings are rated ARL2 (high risk), but are located ~1300m from the start line of LW301. Also, the Metropolitan Fault lies between LW301 and CRO, thereby forming a barrier to mining related movements at the cuttings.</p> <p>While movements of concern are not expected, these cuttings will be included in the monitoring proposed for CRO. Cuttings (2) south of LW301 – The nearer cutting rated ARL3 is ~870m from the LW301 finish line, and the other rated ARL2 is ~1120m from the LW301 finish line. While no discernible movements are expected at these cuttings from the mining of LW305-307, the cuttings will be monitored in accordance with Table 9 of the BFMP.</p>	<p>Survey monitoring at the completion of mining of each longwall.</p> <p>Monitoring of the transmission lines will provide early indications for the cuttings within the 20mm subsidence contour. If the measurements exceed predicted levels, this may trigger a survey to be completed along the cuttings.</p> <p>GNSS monitoring data will give early warning of any movements.</p> <p>Maintenance inspections to include monitoring of rock fall. Inspection will be carried out during the daytime network inspection which occurs at a frequency of once per week with the direction alternating.</p>	E	1	L												<p>No changes in cutting condition predicted. Continue survey monitoring program at end of panels through to LW307. End of LW307 Cutting inspection to be completed.</p>
9	Embankments	Excessive ground movement leading to localised slip failure	Cracks, water, instability.										These are flexible earth structures. Any issues are hypothetical. Not credible for the proposed longwalls.																
10	Furniture		Damage and serviceability issues.										Not credible for the proposed longwalls.																
11	Drains (above cuttings)		Damage to drains.										Not credible for the proposed longwalls.																
12	VMS	Excessive ground movement	Damage to the VMS.										Not credible for the proposed longwalls.																
13	Power lines (not an RMS asset) but may affect RMS assets	Tower / cable failure	Electrical hazard.										Not credible for the proposed longwalls due to the separation distances.																
14		Distortion of bridge elements leading to inconsequential cracking (<0.1mm)	Differential movements between key points on the bridge of up to 5mm										<p>The probability of occurrence of differential movement of this magnitude is as low as 1 in 10. No credible consequences.</p>	<p>Monitoring of differential movements between key points in structure from which effects on the bridge can be assessed.</p> <p>Monitoring systems includes surveying (to pick up 70% key points) and FBG sensor (to pick up 40-50% of key points, but much more accurate).</p> <p>If significant differential movements are detected, increase frequency of monitoring to understand the trend of movement.</p>										<p>No significant change detected to date. FBG monitoring to continue at same frequency. FBG reporting frequency to quarterly.</p> <p>Bridge inspection to be done at end of LW304. Another inspection at end of LW307. Bridge 2 survey to be completed at end of each LW.</p>					
15	Bridge 2 (BN616 - southbound / 617 - northbound)	Distortion of bridge elements leading to cracking that may require repair (between 0.1mm and 1.0mm)	Differential movements between key points on the bridge of 6mm to 15mm.	C	1	L	C	2	M	C	1	L	<p>The probability of occurrence of differential movement of this magnitude is in the order of 1 in 100.</p> <p>Works to repair cracks will affect old Princes Hwy, not the M1.</p>	<p>As above.</p> <p>No economical mitigation measures to prevent the "failure" are possible.</p>	D	1	L	D	2	L	D	1	L	<p>Based on experience to date, frequency is lower than previously estimated. Now "D"</p>					



ID	ASSET	FAILURE TYPE	EVENT	Infra			Function			Safety			COMMENT	ADDITIONAL MITIGATION	Infra			Function			Safety			COMMENT
				F	C	R	F	C	R	F	C	R			F	C	R	F	C	R	F	C	R	
16		Distortion of bridge elements leading to development of wide cracks that would be considered as structural failure (>1.0mm)	Differential movements between key points on the bridge of 16mm to 44mm.	E	5	H	E	5	H	E	2	L	The probability of occurrence of differential movement of this magnitude is in the order of 1 in 2000. If differential movement is at a disadvantageous location, structural failure in the form of severe cracking could occur. This would be unacceptable, and the planned end-of-panel location must be brought forward to a position recommended by the Technical Committee well before differential movements reach this magnitude, for a termination of mining earlier than planned to avoid failure of the structure.	As above. No economical mitigation measures to prevent the "failure" are possible.	E	5	H	E	5	H	E	2	L	Likelihood reduced but not to "hypothetical level"
17	Cawley Road Overpass (BN615)	Distortion of bridge elements leading to inconsequential cracking (<0.1mm)	Differential movements between key points on the bridge of up to 10mm.										The probability of occurrence of differential movement of this magnitude is as low as 1 in 10. No credible consequences.	Monitoring of differential movements between key points in structure from which effects on the bridge can be assessed. If significant differential movements are detected, increase frequency of monitoring to understand the trend of movement.										GNSS9 is reporting no movement. End of Panel surveys will be discontinued unless appreciable movement at GNSS 9 recorded (>30mm). Final confirmatory survey of bridge prisims at end LW that reaches 5x depth of cover.
18		Distortion of bridge elements leading to cracking that may require repair (between 0.1mm and 1.0mm)	Differential movements between key points on the bridge greater than 10mm and up to 20mm (the upper bound value).										The probability of occurrence of differential movement of this magnitude is in the order of 1 in 100 to 1 in 2000. No credible consequences.	As above.										As above

**NOTE:**  
RMS guidelines state a coverage zone of 5 times depth of mine (~2km).  
All mitigation measures, regardless of the cell in which they are recorded, are deemed to apply to all risk events. Furthermore, control and mitigation measures listed in the report are also deemed to apply to all risk events in the risk register.

## **Appendix B**

### **Workshop Participants**



## Appendix C

### Workshop Agenda

# Subsidence Impacts on RMS Assets LW305-307 AGENDA

- Introductions
- Overview of LW305-307 extraction
- Subsidence predictions for LW305-307
- Subsidence performance to date
- RMS Asset Risk Assessment
  - Carriageway
  - Kerb
  - Embankments
  - Drains
  - Powerlines
  - Cawley Road Overpass (BN615)
  - Culverts
  - Cuttings
  - Furniture
  - VMS
  - Bridge 2 (BN616 Sb – BN617 Nb)
- Next Steps

## **Appendix D**

### **Risk Criteria**

# ROADS & MARITIME SERVICES

## RISK ASSESSMENT - SUBSIDENCE IMPACTS ON RMS ASSETS

### FREQUENCY



Level	Descriptor	Alt. Description	Description	Chance %	Frequency
O	<b>Absolutely Certain</b>	Definite	This event will occur - known to occur now - <i>Will occur several (many) times each year and many times (constantly) during this project</i>	99.99	Several times each year
A	<b>Almost Certain</b>	Frequent	This event is expected to occur in most circumstances - <i>Expected to occur more than once during the duration of this project</i>	95	1 / year
B	<b>Likely</b>	Probable	This event will probably occur in most circumstances - <i>Expected to occur once during the duration of the project</i>	10	at least 1 / 10 years
C	<b>Possible</b>	Occasional	This event might (should) occur at some time - <i>Not likely to occur in life of project, but it is possible.</i>	1	at least 1 / 100 years
D	<b>Unlikely</b>	Remote	This event could occur at some time - <i>Unlikely (very) to occur in life of project</i>	0.1	at least 1 / 1,000 years
E	<b>Rare</b>	Very Unlikely	This event may occur in exceptional circumstances - <i>Examples of this have occurred historically, but it is not anticipated for this project</i>	0.01	at least 1 / 10,000 years
F	<b>Hypothetical</b>	Barely credible	Theoretically possible but never occurred to date (anywhere in the world) - <i>Often applied to natural events</i>	1.00E-03	every Million years

# ROADS & MARITIME SERVICES

## RISK ASSESSMENT - SUBSIDENCE IMPACTS ON RMS ASSETS

### CONSEQUENCES



Level	Descriptor	Infrastructure			Amenity			Safety / Societal Cost
		Pavement	Bridges	Cost	Access	Speed	Political	
1	Insignificant	Minor damage	Minor repairable damage	< \$50 k	Some loss in condition	No traffic effect	No political impact	No injuries or health effects
2	Minor	Noticeable damage	Damage that will deteriorate if not repaired quickly	< \$100 k	One lane closed for < half day. One planned lane closure < 1 day	Speed reduction for < 1 month - 80 kph	Minimal political impact (brief press coverage)	First aid treatment or minor damage to vehicles
3	Moderate	Significant damage	Significant damage	< \$1 Mk	One lane closed for < 1 day	Speed reduction for > 1 month - 80 kph or < 1 day - 40 kph	Political impact (press coverage)	Medical treatment required
4	Major	Extensive damage	Major damage - restricted speed	< \$10 M	One lane closed for > 1 day	Speed reduction for < 1 month - 40 kph	Significant political impact (extensive negative press coverage)	Extensive injuries or one or two permanent disabilities
5	Catastrophic	Loss of use of carriageway	Extensive damage. One carriageway closed until repaired	< \$50 M	One carriageway closed for > 1 day or both cways for < 2 day	Speed reduction for > 1 month - 40 kph	Major political impact (Commission of Enquiry)	Single fatality or severe permanent disabilities to several people
6	Untenable		Total failure of bridge or closed until repaired	> \$50 M	Both carriageways closed for > 2 day	Speed restrictions for > 12 months - 40 kph		Multiple fatalities

ARUP

**ROADS & MARITIME SERVICES**  
**RISK ASSESSMENT - SUBSIDENCE IMPACTS ON RMS ASSETS**  
**RISK MATRIX**



LIKELIHOOD		CONSEQUENCES					
		1 (Insignificant)	2 (Minor)	3 (Moderate)	4 (Major)	5 (Catastrophic)	6 (Unthinkable)
Multiple	O	H	E	E	E	E	E
Almost Certain	A	H	H	E	E	E	E
Likely	B	M	H	H	E	E	E
Possible	C	L	M	H	E	E	E
Unlikely	D	L	L	M	H	E	E
Rare	E	L	L	M	H	H	E
Hypothetical	F	L	L	L	M	H	H

<b>Low</b>	Low risk; managed by routine procedures.
<b>Moderate</b>	Moderate risk; requires above normal attention.
<b>High</b>	High risk; ALARP must be applied.
<b>Extreme</b>	Extreme risk; not acceptable and must be reduced.

## Appendix E

### Peabody BFMP Presentation

# Metropolitan Colliery



RMS  
Longwalls 305 to 307



20 August 2019

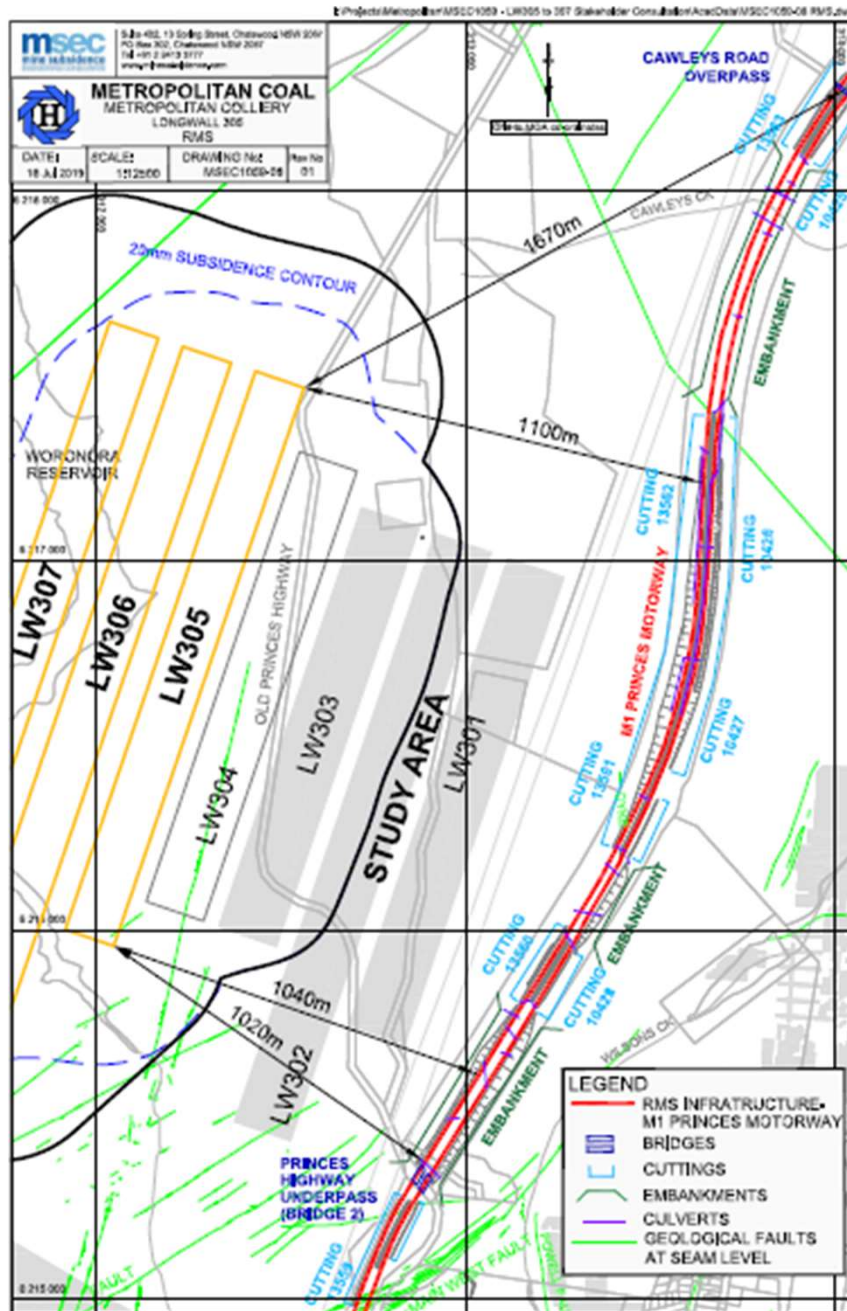

- Monitoring Data LW301-303, 304
- LW305 to 307 predictions

LW	Overall Void Length Including Installation Heading (m)	Overall Void Width Including First Workings (m)	Overall Tailgate Chain Pillar Width (m)
LW304	1,286	163	45
LW305	1,596	138	45
LW306	1,956	138	70
LW307	1,956	138	70

# 301 to 303 Monitoring

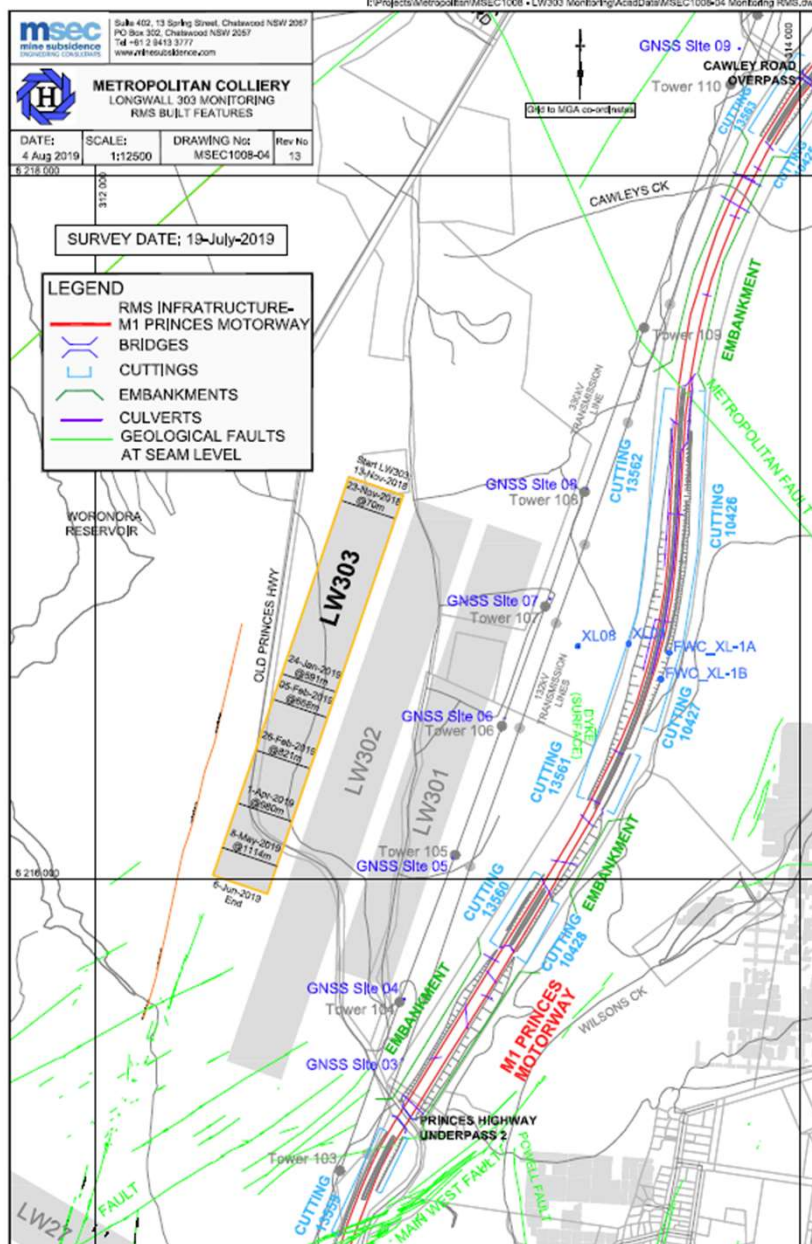

- GNSS Units – along transmission line
- FBG system – Bridge 2
- Terrestrial survey – Bridges and M1 Princes Motorway
- RMS Network Safety Inspection – twice weekly
- Pavement Inspection – End of panel
- Cutting closure marks
- CCTV

# 301 to 303 Monitoring - Bridges



Monitoring Activity	Frequency	Maximum Result	BFMP Tarp Status	Comments
<b>Bridge 2</b>				
GNSS Station 03 Incremental Horizontal Movement	10 sec – Averaged over 24hrs	8mm	Normal	Measured 28 July 2019. Movement direction NNW.
GNSS Station 03 Total Horizontal Movement		30mm	Normal	Measured 28 July 2019. Movement direction NNW.
GNSS Station 03 Incremental Subsidence		0mm	Normal	Measured 28 July 2019.
GNSS Station 03 Total Subsidence		21mm	Normal	Measured 28 July 2019.
FBG	2 sec – Averaged over 6hrs	+5.5mm (Opening) -3.1mm (Closing)	Normal	Data to 30 July 2019. Movements are generally similar to those recorded previously. No cause for concern as reported by Cardno 10 July 2019 and 5 August 2019.
<b>Cawley Rd Bridge</b>				
GNSS Station 09 Incremental Horizontal Movement	10 sec – Averaged over 24hrs	0mm	Normal	Measured 28 July 2019
GNSS Station 09 Total Horizontal Movement		2mm	Normal	Measured 28 July 2019
GNSS Station 09 Incremental Subsidence		-5mm	Normal	Measured 28 July 2019
GNSS Station 09 Total Subsidence		-14mm	Normal	Measured 28 July 2019

- GNSS Units – both bridges
- FBG system  
Bridge 2 – seasonal variation
- Terrestrial survey – problem with accuracy and disturbance
- Inspections



# 301 to 303 Monitoring - FBG



Cardno (NSW/ACT)

Underpass 2 – FBG Monitoring  
X and Y Relative Movements

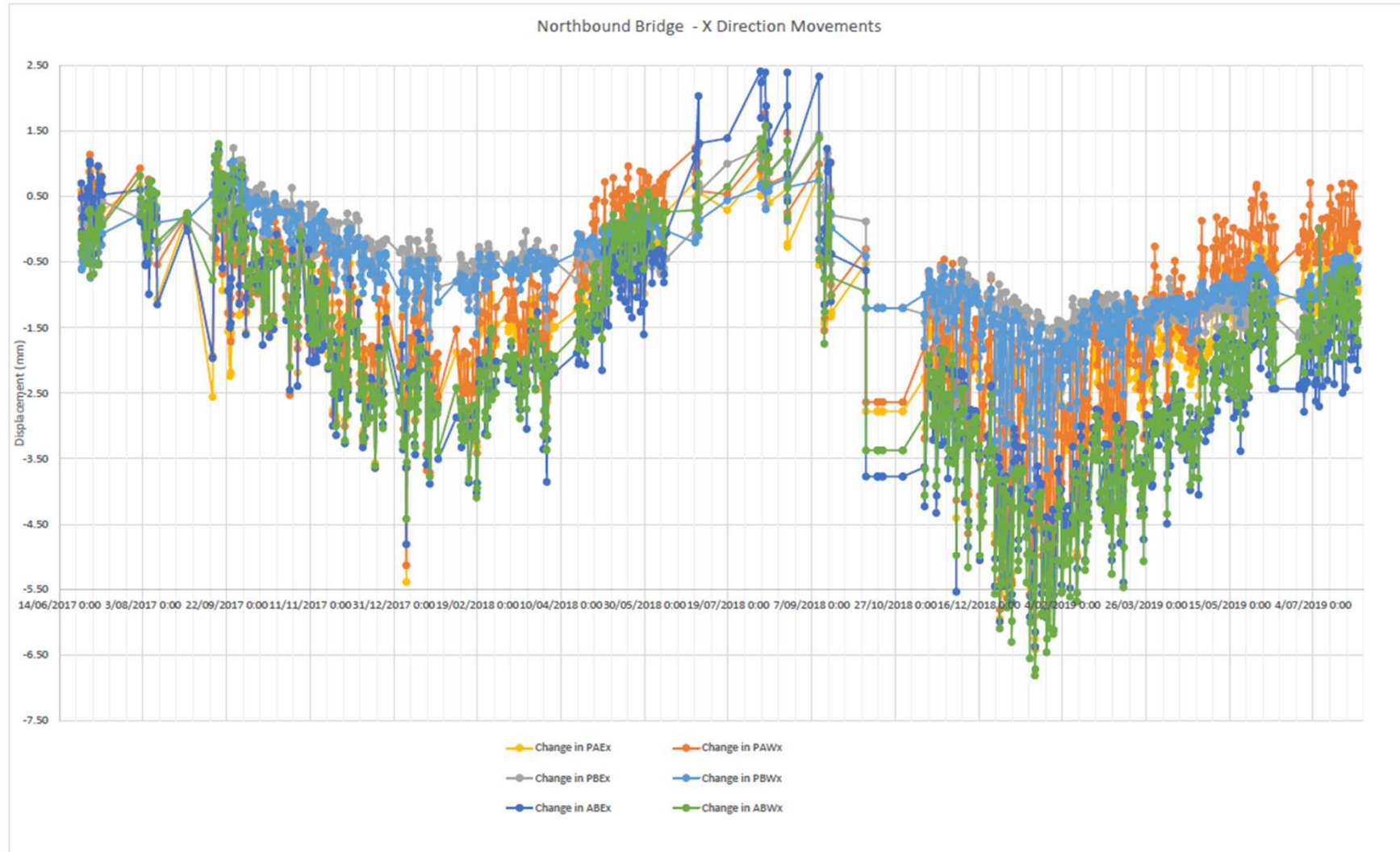

# 301 to 303 Monitoring - FBG



Cardno (NSW/ACT)

Underpass 2 – FBG Monitoring  
X and Y Relative Movements

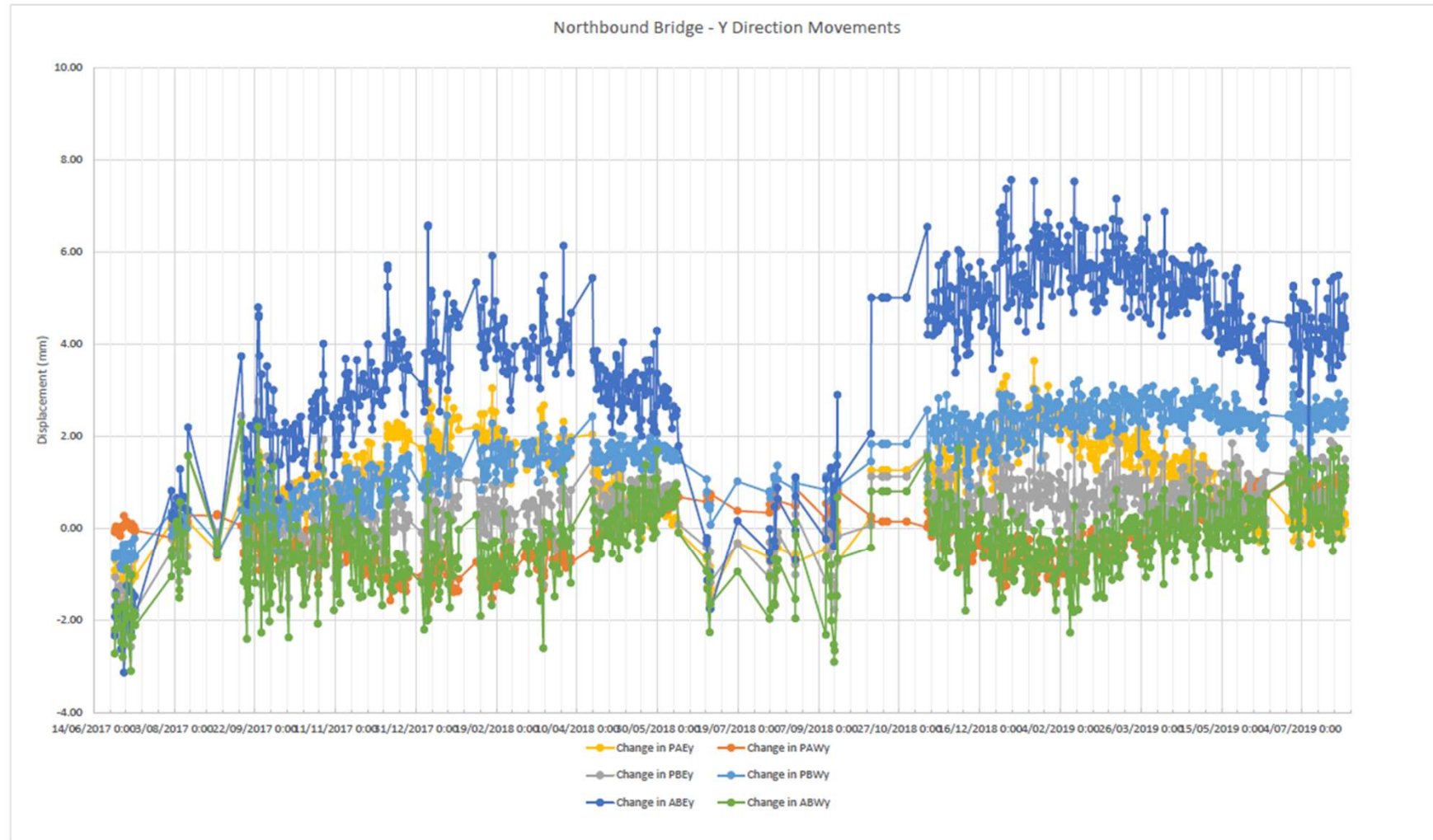

# 301 to 303 Monitoring - FBG



Cardno (NSW/ACT)

Underpass 2 – FBG Monitoring  
X and Y Relative Movements

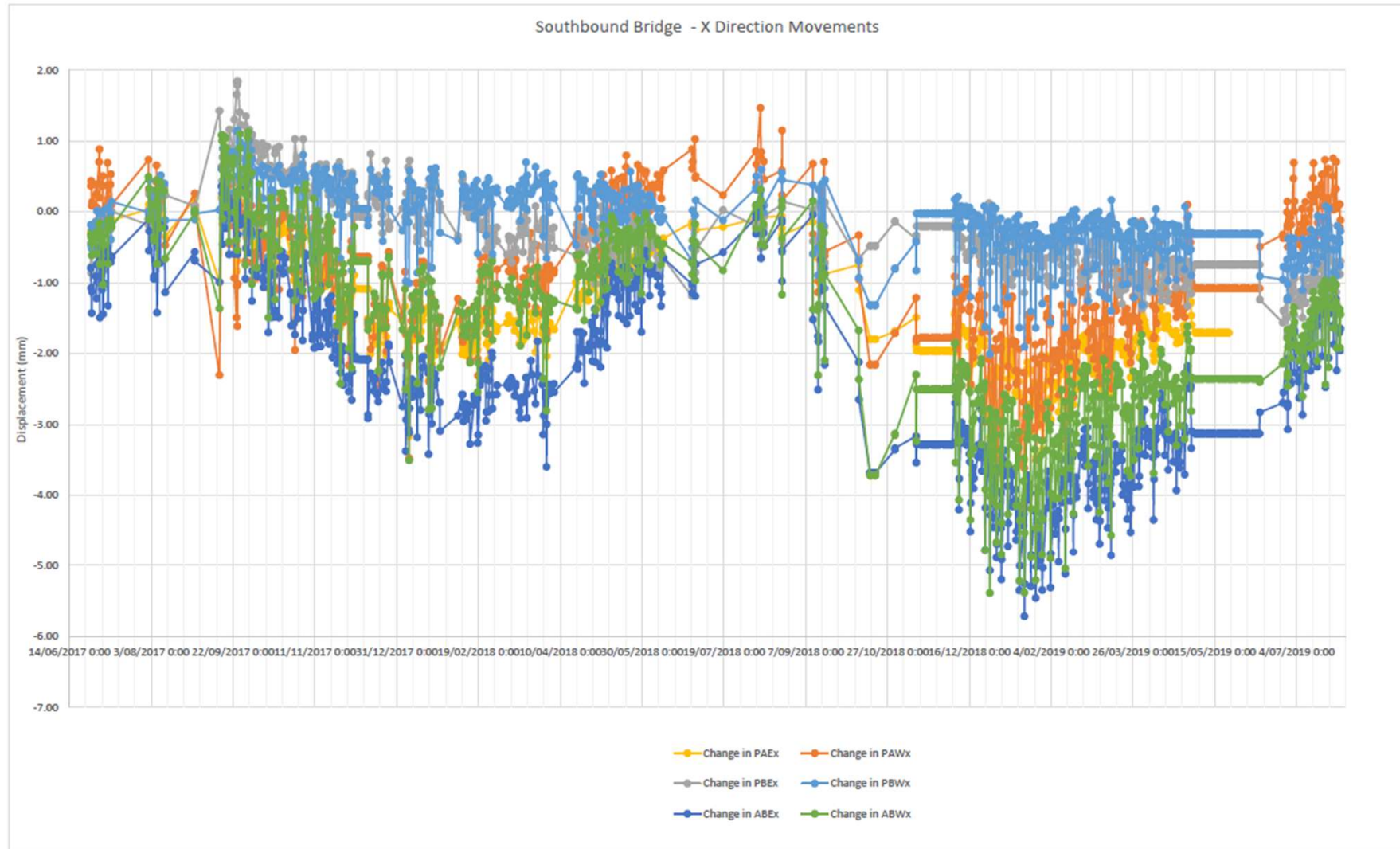

# 301 to 303 Monitoring - FBG



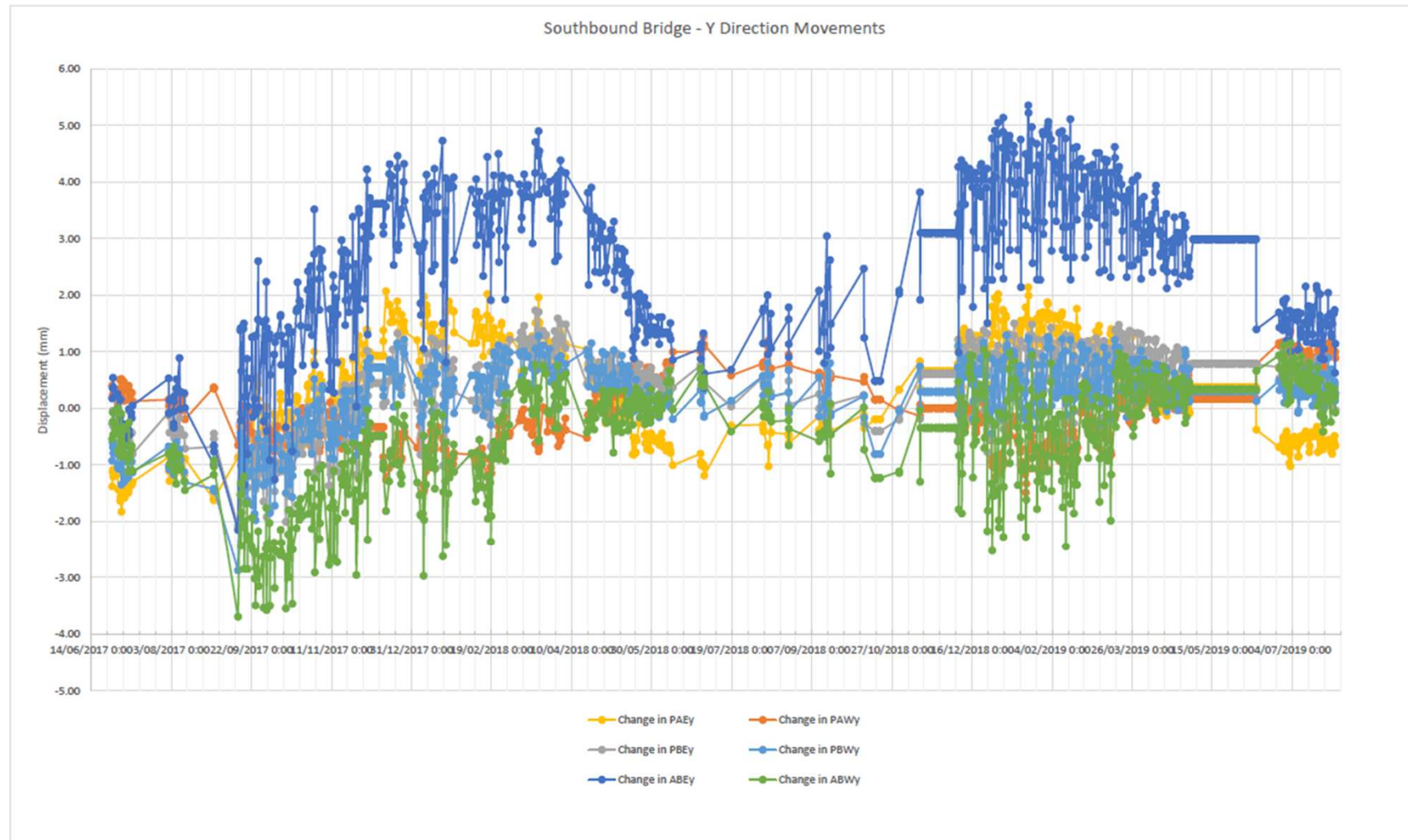

Cardno (NSW/ACT)

Underpass 2 – FBG Monitoring  
X and Y Relative Movements



# 301 to 303 Monitoring – M1



Pavements (M1 Princes Motorway) – Surveyed 19 July 2019				
Total Subsidence (Freeway Line)	End of Panel unless otherwise determined by Technical Committee.  Latest survey 19 Jul 2019	34mm	 Normal	At mark FW180, surveyed 19 July 2019
Total Horizontal Movement (Freeway Line)		66mm	 Normal	At mark FW229. Movement direction W. Maximum GNSS horizontal movement at Station 06, 126 mm at 28 July 2019.
Total Strain (Freeway Line)		+0.1mm/m (tensile) -0.5mm/m (compressive)	 Normal	Maximum tensile strain between Marks FW244-FW245. Maximum compressive strain between Marks FW284-FW285.  No observed non-conventional subsidence movements or development of compressive strain along Transmission Line.
RMS Network Safety Inspection	Twice weekly by RMS	No reports of impacts	N/A	Reporting by exception
Pavement Inspection	End of panel	No reports of impacts	N/A	Inspection to be completed for Longwall 303 extraction.

# 301 to 303 Monitoring – M1



**Profiles of Incremental Subsidence, Tilt and Strain along the Freeway Line due to Metropolitan Colliery LW303**

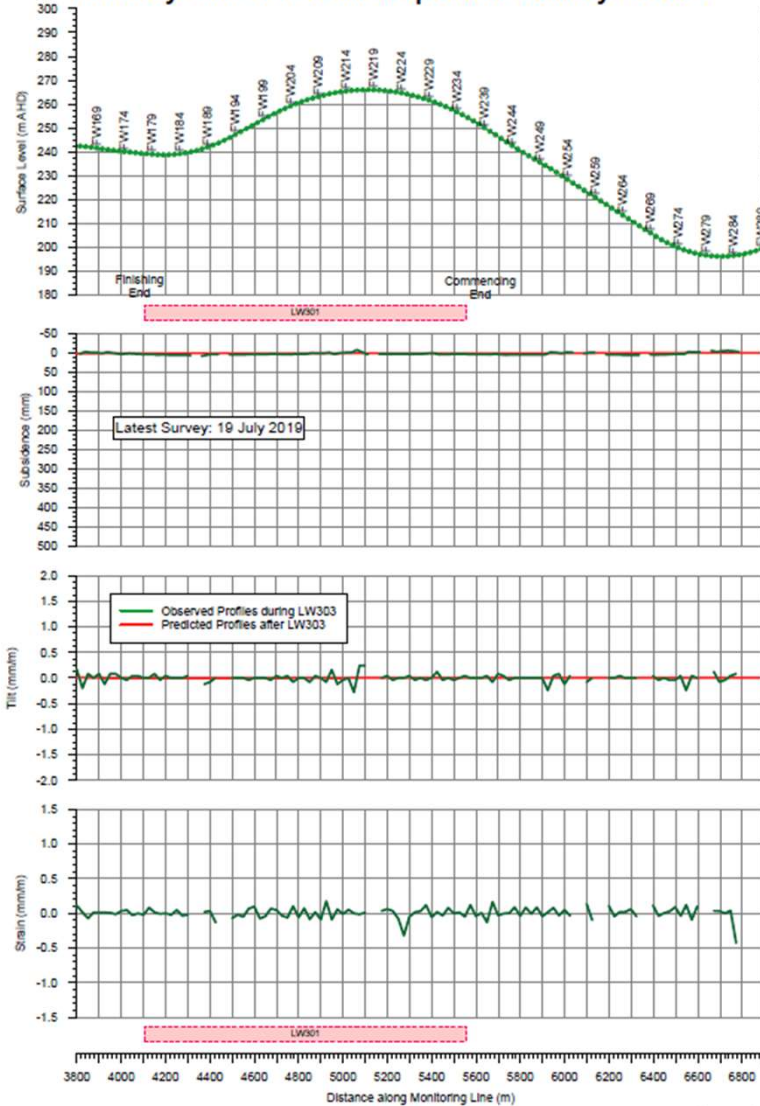

**Profiles of Total Subsidence, Tilt and Strain along the Freeway Line due to Metropolitan Colliery LW301 to 303**

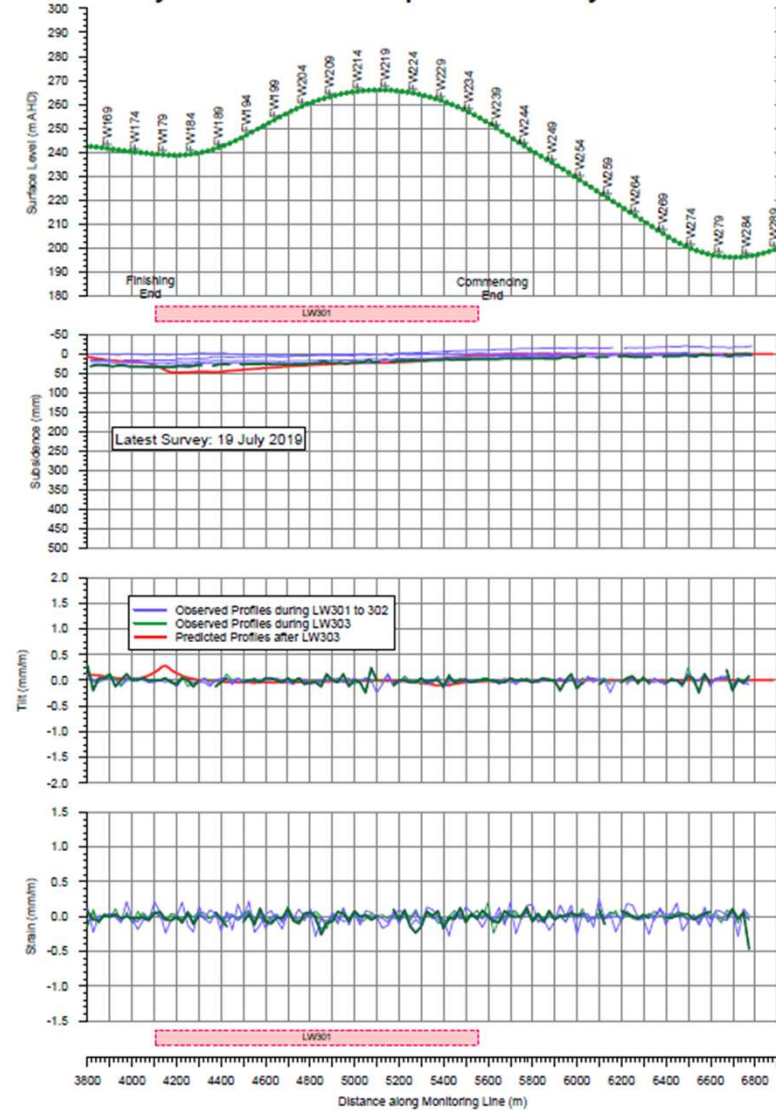

# 301 to 303 Monitoring – M1



GNSS Stations Total Horizontal Movement due to Longwall 301 to 303

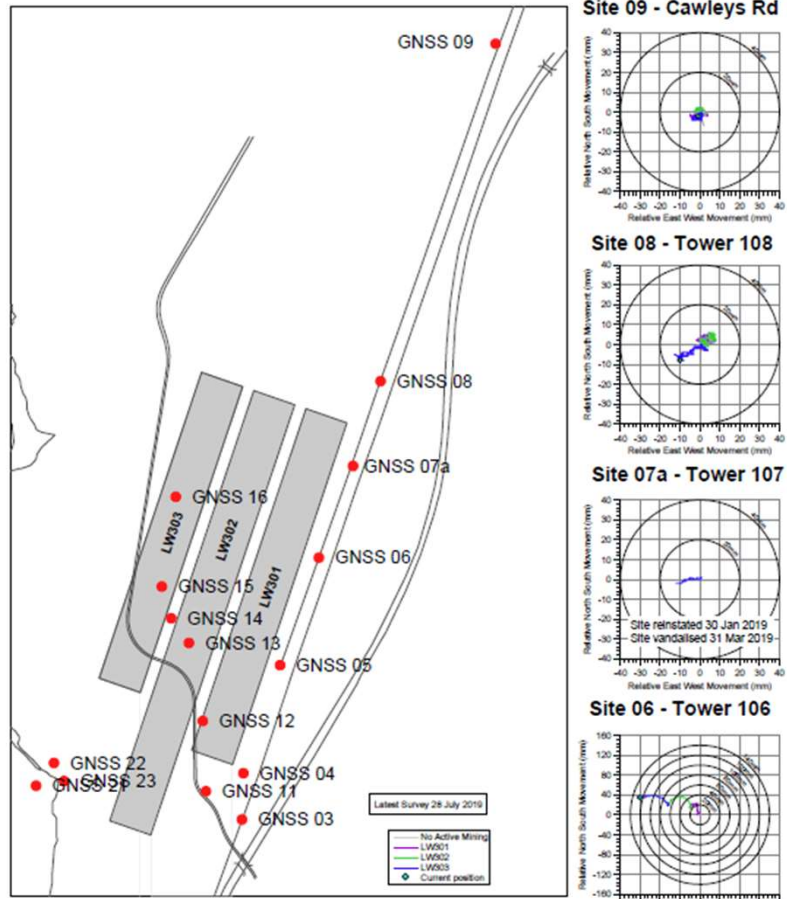

Observed Total Subsidence at GNSS Monitoring Stations

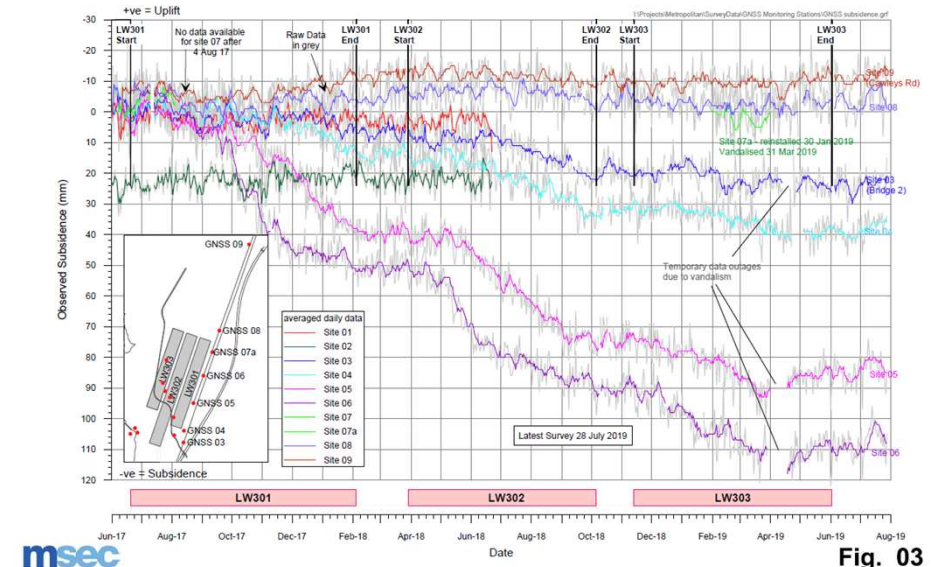

Fig. 03

Observed Opening and Closure between GNSS Monitoring Stations

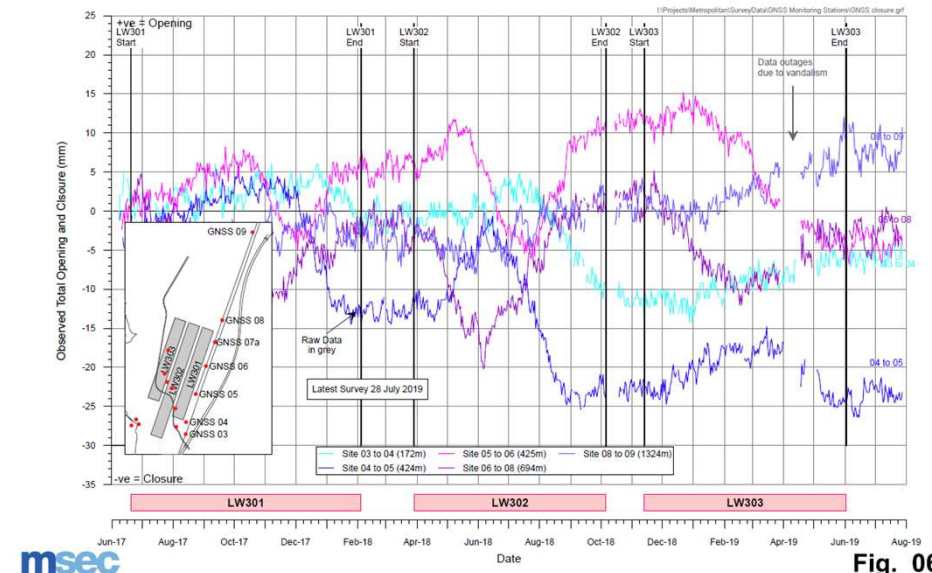

Fig. 06

# 301 to 303 Monitoring – M1



Monitoring Activity	Frequency	Maximum Result (mm)	BFMP Tarp Status	Comments
<b>Cuttings (M1 Princes Motorway)</b>				
RMS Network Safety Inspection	Twice weekly by RMS	No reports of impacts	N/A	Reporting by exception
M1 Cutting closure marks Total Closure due to Longwall 303 only	End of Panel unless otherwise determined by Technical Committee.	0mm	N/A	Marks reinstated during Longwall 303.
Visual Inspection	End of Panel unless otherwise determined by Technical Committee.		N/A	No survey undertaken since baseline.
<b>Culverts (M1 Princes Motorway)</b>				
CCTV Inspection	End of Panel unless otherwise determined by Technical Committee.		N/A	No survey undertaken since baseline.
<b>Data review by geotechnical and mine subsidence specialists</b>				
No review required. End of panel survey to be carried out in accordance with BFMP.				

# Predictions – LW305 to 307



- > 1020m, outside study area boundary
- No measurable conventional subsidence, tilt, strain
- 40mm far-field horizontal movement based on 95% confidence level
- No predicted valley closure at culverts
- Geological structures

# Predictions – LW305 to 307



- Differential movement at bridges – statistical
- Little change after LW304

## Bridge 2

	1 in 20 probability (95% confidence level)	1 in 100 probability (99% confidence level)	1 in 2000 probability (99.95% confidence level)
Opening	5 mm	9 mm	20 mm
Closing	5 mm	9 mm	21 mm
Mid-Ordinate Deviation	8 mm	12 mm	18 mm

## Cawleys Rd Bridge

	1 in 20 probability (95% confidence level)	1 in 100 probability (99% confidence level)	1 in 2000 probability (99.95% confidence level)
Opening	4 mm	7 mm	14 mm
Closing	5 mm	9 mm	19 mm
Mid-Ordinate Deviation	7 mm	10 mm	16 mm

# Predictions – LW305 to 307



- Impact unlikely due to conventional movements
- Monitoring for non conventional movements

**The End**

## **Appendix F**

### **MSEC Subsidence Report**

05<sup>th</sup> August 2019

Jon Degotardi  
Peabody Energy Australia  
Metropolitan Colliery  
PO Box 402  
Helensburgh NSW 2508

Ref: MSEC1059-08

Dear Jon,

**RE: Metropolitan Colliery – Proposed Longwalls 305 to 307 - Subsidence Predictions and Impact Assessments for the Roads and Maritime Services Infrastructure**

Metropolitan Coal is a wholly owned subsidiary of Peabody Energy Pty Limited (Peabody) and operates Metropolitan Colliery (the Colliery), which is located in the Southern Coalfield of New South Wales. Metropolitan Coal has extracted Longwalls 1 to 27, 301 to 303 at the Colliery and, at the time of this report, had commenced extraction of Longwall 304. The Roads and Maritime Services (RMS) infrastructure has been managed during the extraction of Longwalls 301 to 304 by a Technical Committee and in accordance with the Built Features Management Plan for RMS.

This letter report summarises the predicted subsidence movements and the assessed subsidence impacts for the Roads and Maritime Services (RMS) infrastructure resulting from the extraction of the proposed Longwalls 304 at Metropolitan Colliery.

The locations of the RMS infrastructure and the proposed longwalls are shown in the attached Drawing No. MSEC1059-08. The M1 Princes Motorway is located to the east of Longwall 305. The distance of the M1 Princes Motorway from Longwalls 305 varies from 1040 m near the finishing (southern) end to 1,100 m near the commencing (northern) end of Longwall 305. Longwalls 301 to 304 are located closer to the M1 Princes Motorway with 210 metres distance to the finishing (southern) end of Longwall 301 and 335 metres distance to the commencing (northern) end of Longwall 301.

A series of cuttings and embankments up to a maximum height of approximately 20 metres are shown in the attached Drawing No. MSEC1059-08. A summary of the rock cuttings is provided in Table 1.

**Table 1 Summary of RMS Rock Cuttings**

RMS Slope Number	RMS Assessed Risk Level (ARL)	Length (m)	Maximum Slope Height (m)	Average Slope Angle (degrees)
13563	2	202	17	65
13562	3	531	18	70
13561	4	599	13	62
13560	3	231	8	70
10425	3	188	9	66
10426	4	503	15	55
10427	4	452	14	55
10428	4	192	9	65

A bridge is located at the crossing of the M1 Princes Motorway with the Old Princes Highway (Bridge 2), and is located approximately 1,020 metres from Longwall 305. The next nearest bridge is Cawley Road Overpass, which is located approximately 1.67 kilometres to the commencing end of Longwall 305.

A series of culverts cross the M1 Princes Motorway, as shown on Drawing No. MSEC1059-08. The culverts comprise pipes of varying diameters from 375 mm to 1800 mm. The pipe materials comprise asbestos cement (pipes up to 600 mm diameter) and steel reinforced concrete (pipes up to 1800 mm diameter). In addition to the culverts, there are also a number of other drainage structures, such as kerbs, gutters, pits and drainage pipes. The largest culvert comprises two 1800mm pipes located to the north east of the longwalls at Cawley's Creek.

The predictions and impact assessments for the RMS infrastructure are provided in the following sections.

### Conventional Subsidence Parameters for the RMS Infrastructure

The Study Area for Longwall 304 is defined as the surface area that is likely to be affected by the proposed mining of these longwalls (i.e. from conventional subsidence) and is based on the further extents of a 35° angle of draw line from the proposed extents of the longwalls and the predicted 20 mm subsidence contour resulting from the extraction of Longwalls 305 to 307. The study area and the predicted 20mm subsidence contour for the extraction of Longwall 304 is are shown in Drawing No. MSEC1059-08.

At over 1,020 m from Longwall 305, the RMS assets are located outside the Study Area and are not expected to experience measurable conventional vertical subsidence, tilts, curvatures or strains (i.e. no greater than survey accuracy). The RMS assets could however experience low level far-field horizontal movement.

The observed incremental far-field horizontal movements, resulting from the extraction of longwalls in the Southern Coalfield, are provided in Figure 1. The data are based on survey marks located in areas influenced by previously extracted longwall panels.

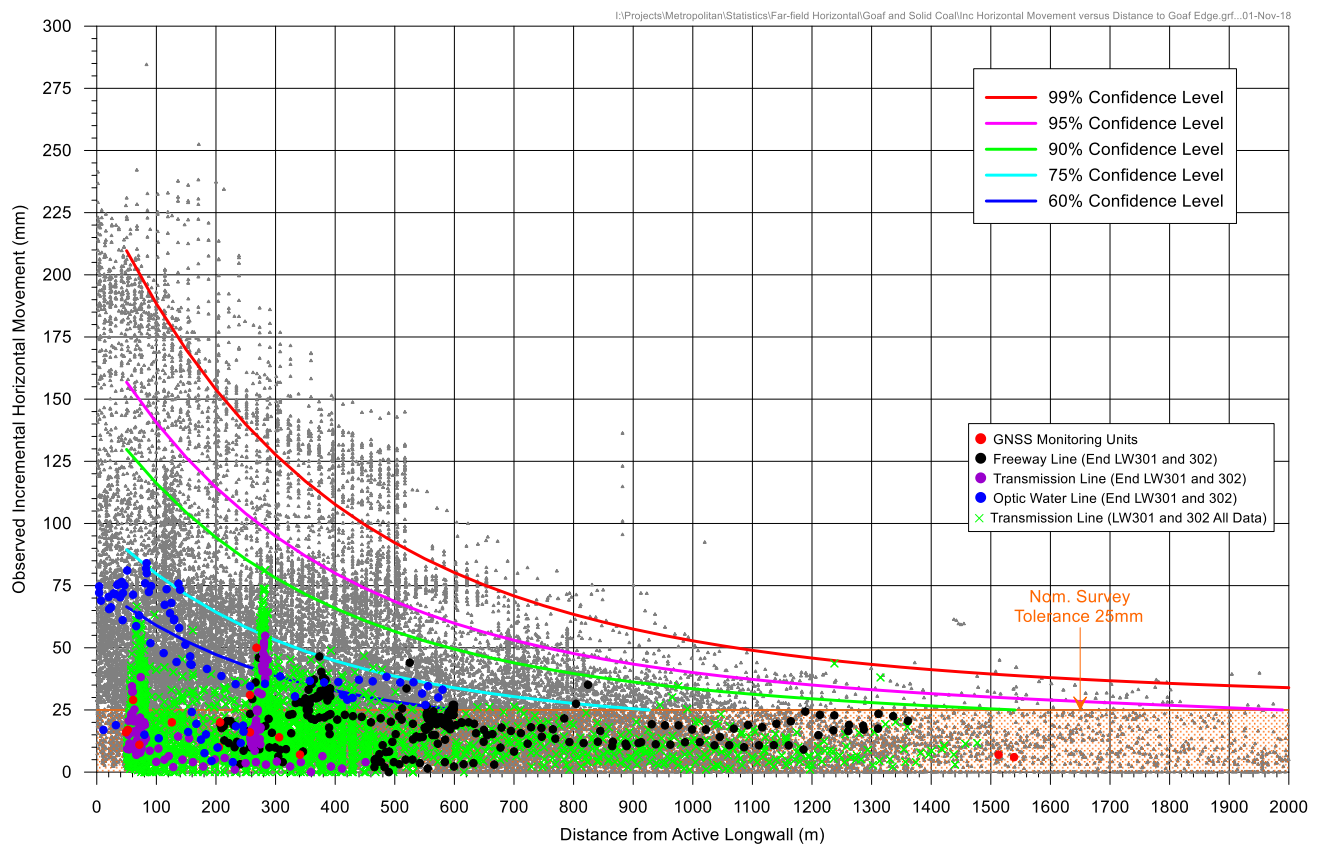

**Figure 1 Observed Incremental Far-field Horizontal Movements from the Southern Coalfield**

The observed horizontal movements during the extraction of Longwalls 301 and 302 are also plotted in Figure 1. The absolute horizontal movements measured at distances greater than 1,020 metres from mining are in the order

of 40 mm based on the 95 % confidence level. These low level movements comprise a large proportion of survey tolerance. Far-field horizontal movements tend to be bodily movements orientated towards the mining area. The strains associated with these low level horizontal movement are not expected to be measurable.

### **Potential for Non-Conventional Movements**

Non-conventional movements can develop due to the presence of geological structures or valley related effects. In some cases, non-conventional movements can develop with no known cause and these are often referred to as 'anomalous' movements.

The locations of the known geological structures at seam level and the major streams are shown in Drawing No. MSEC982-08. There are no identified geological structures within the Study Area that extend beneath the M1 Princes Motorway. The M1 Princes Motorway crosses the Metropolitan Fault approximately 1,100m from Longwall 305. It is noted that the faults shown in Drawing No. MSEC982-08 are identified at seam level and surface expression of faults may occur at different locations, or faults may not have continuity to the ground surface.

A small drainage line crosses the M1 Princes Motorway approximately 1,020m east of the finishing end of Longwall 305. A second drainage line is located to the north of the longwalls at Cawley's Creek and is 1.35km from LW305). At these distance, the culverts are not predicted to experience valley related movements greater than survey accuracy, due to the extraction of Longwalls 305 to 307.

Valley closure is not expected to occur in the cuttings along the M1 Princes Motorway, however, minor closure movements could be observed due to differential horizontal movements.

### **Impact Assessments for the RMS Infrastructure**

The M1 Princes Motorway is located more than 1 km from Longwall 305 and is outside the Study Area boundary for Longwalls 305 to 307.

The motorway (including bridges and associated features) is not expected to experience measurable conventional vertical subsidence, tilt, curvature and strain. The M1 Princes Motorway could experience far-field horizontal movements resulting from the extraction of the Longwall 305 of up to 40 mm, based on the 95% confidence level for observed far-field horizontal movement data for the Southern Coalfield. The observed horizontal movements are however, expected to be less than these values. Observed horizontal movements have been recorded at several real time GNSS monitoring units located to the east of Longwalls 301 to 303. The observations to date show a maximum observed incremental horizontal movement of 15 mm at 1 km from an active longwall.

Adverse impacts to the M1 Princes Motorway, including the road pavement, slopes, culverts, barriers and furniture, resulting from conventional subsidence movements is considered unlikely to occur due to the extraction of Longwall 305 to 307.

Bridge 2 (RMS reference BN616-southbound and BN617-northbound) is located approximately 1,020 m to the south east of Longwall 305 as shown in Drawing No. MSEC1059-08. The next nearest bridge is Cawleys Rd overpass (RMS reference BN615), located approximately 1.67 km from Longwall 305.

The potential for differential horizontal movement at the bridges was assessed by analysing the far-field horizontal movement data. The data set was analysed to determine incremental relative opening and closing and incremental mid ordinate deviation.

Relative opening and closing movement is calculated as the change in the distance between two survey marks (either positive opening, or negative closing) over two survey epochs.

A plot of the calculated incremental relative opening and closing movement for the current database of observed far-field horizontal movements that were used for this assessment is provided in Figure 2. The incremental relative opening and closing movement was calculated for pegs with a spacing of 20 m  $\pm$ 10 m.

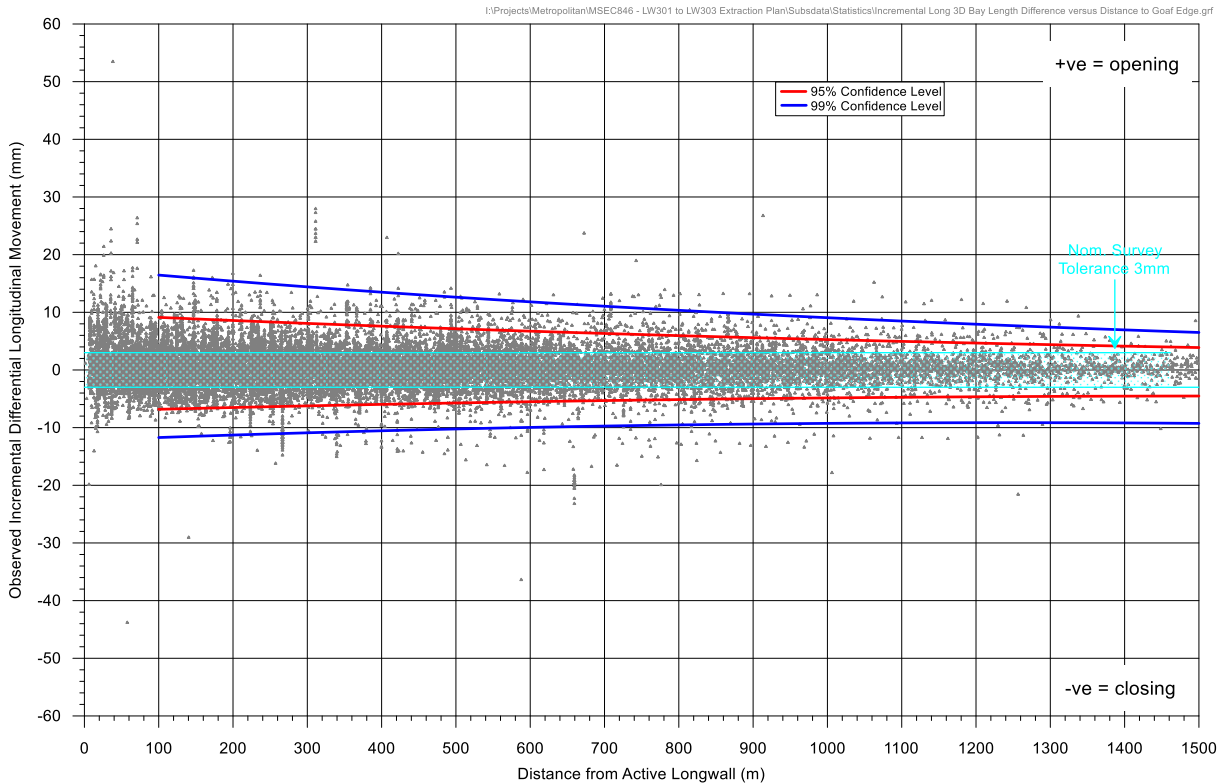

**Figure 2 Incremental Differential Horizontal Movements versus Distance from Active Longwall for Marks Spaced at 20 m ±10 m**

Mid ordinate deviation provides a measure of out of plane movement or horizontal bending by calculating the mid ordinate deviation between three survey pegs. The mid ordinate deviation is the change in perpendicular horizontal distance from a point to a chord formed by points on either side. A schematic sketch of the mid ordinate deviation is provided in Figure 3

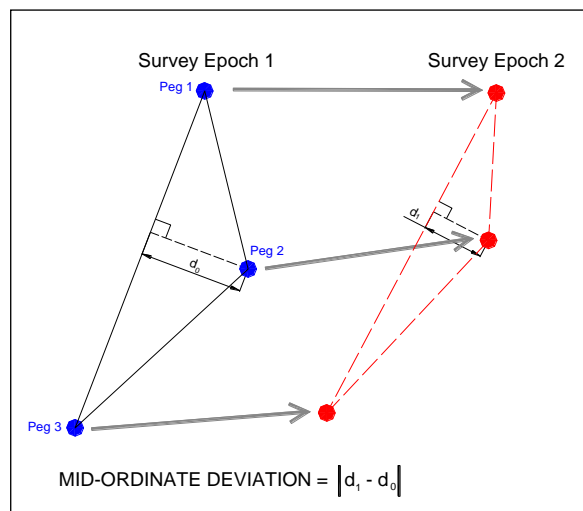

**Figure 3 Schematic Representation of Mid Ordinate Deviation**

A plot of the calculated incremental mid-ordinate deviation for the current database of observed far-field horizontal movements that were used for this assessment is provided in Figure 4. The mid-ordinate deviation was calculated for pegs with a spacing of 20 m ±10 m, or an approximate spacing of 40 m over the three pegs.

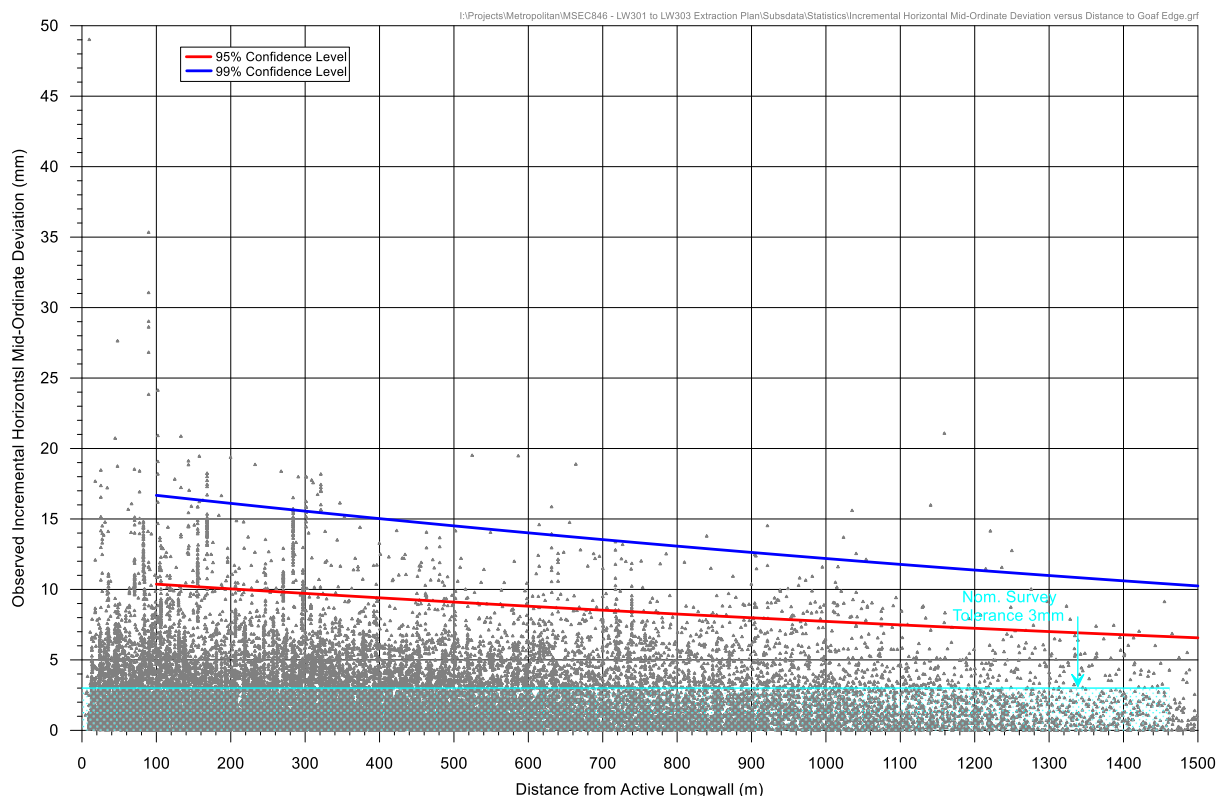

**Figure 4 Observed Incremental Mid Ordinate Deviation versus Distance from Active Longwall for Marks Spaced at 20 m ±10 m**

The incremental relative opening and closing and mid ordinate deviation for various probabilities for Bridge 2 at a distance of approximately 1,020 metres from an active longwall are summarised in Table 2.

**Table 2 Incremental Relative Opening, Closing and Mid-Ordinate Deviation at Approximately 880 metres Distance from Active Longwall**

	1 in 20 probability (95% confidence level)	1 in 100 probability (99% confidence level)	1 in 2000 probability (99.95% confidence level)
Opening	5 mm	9 mm	20 mm
Closing	5 mm	9 mm	21 mm
Mid-Ordinate Deviation	8 mm	12 mm	18 mm

The incremental relative opening and closing and mid ordinate deviation for various probabilities for Cawleys Road Overpass at a distance of approximately 1.67 kilometres from an active longwall are summarised in Table 3.

**Table 3 Incremental Relative Opening, Closing and Mid-Ordinate Deviation at Approximately 1.67 kilometres Distance from Active Longwall**

	1 in 20 probability (95% confidence level)	1 in 100 probability (99% confidence level)	1 in 2000 probability (99.95% confidence level)
Opening	4 mm	7 mm	14 mm
Closing	5 mm	9 mm	19 mm
Mid-Ordinate Deviation	7 mm	10 mm	16 mm

An assessment of Bridge 2 and Cawleys Road overpass by Cardno was undertaken for the extraction of Longwalls 301 to 303 and indicated that the bridges were sensitive to small differential movements. Given closer proximity of Bridge 2 to the extracted longwalls, a high accuracy monitoring system, using fibre optic monitoring, was implemented by the RMS technical committee to monitor movements at Bridge 2. A monitoring system for Cawleys Road overpass using fixed survey prisms was established.

It is recommended assessment of the bridges be undertaken by the RMS technical committee to review the suitability of the monitoring and management strategies that were developed for Longwalls 301 to 303.

### Summary

The M1 Princes Motorway is located greater than 1,020 metres to the east of Longwall 305. The two nearest bridges, Bridge 2 and Cawleys Road Overpass, are located 1,020 m and 1.67 km from Longwall 305 respectively. The RMS infrastructure is located outside the Study Area for Longwall 304. At these distances, the RMS infrastructure is not expected to experience measurable conventional subsidence movements but could experience low level far-field horizontal movements.

It is recommended that monitoring and management strategies developed for the extraction of Longwalls 301-304 are updated and continued, in consultation with RMS, to manage the potential impacts on the RMS infrastructure. It is expected that the RMS infrastructure can be maintained in safe and serviceable conditions with the implementation of the appropriate monitoring and management strategies.

Yours sincerely

Peter DeBono

Mine Subsidence Engineering Consultants

Attachments:

Drawing No. MSEC1059-08 – Longwall 305 to 307 – RMS

**msec**  
mine subsidence  
ENGINEERING CONSULTANTS

Suite 402, 13 Spring Street, Chatswood NSW 2067  
PO Box 302, Chatswood NSW 2057  
Tel +61 2 9413 3777  
www.minesubsidence.com

**METROPOLITAN COAL**  
METROPOLITAN COLLIERY  
LONGWALL 305  
RMS

DATE: 16 Jul 2019	SCALE: 1:12500	DRAWING No: MSEC1059-08	Rev No 01
----------------------	-------------------	----------------------------	--------------

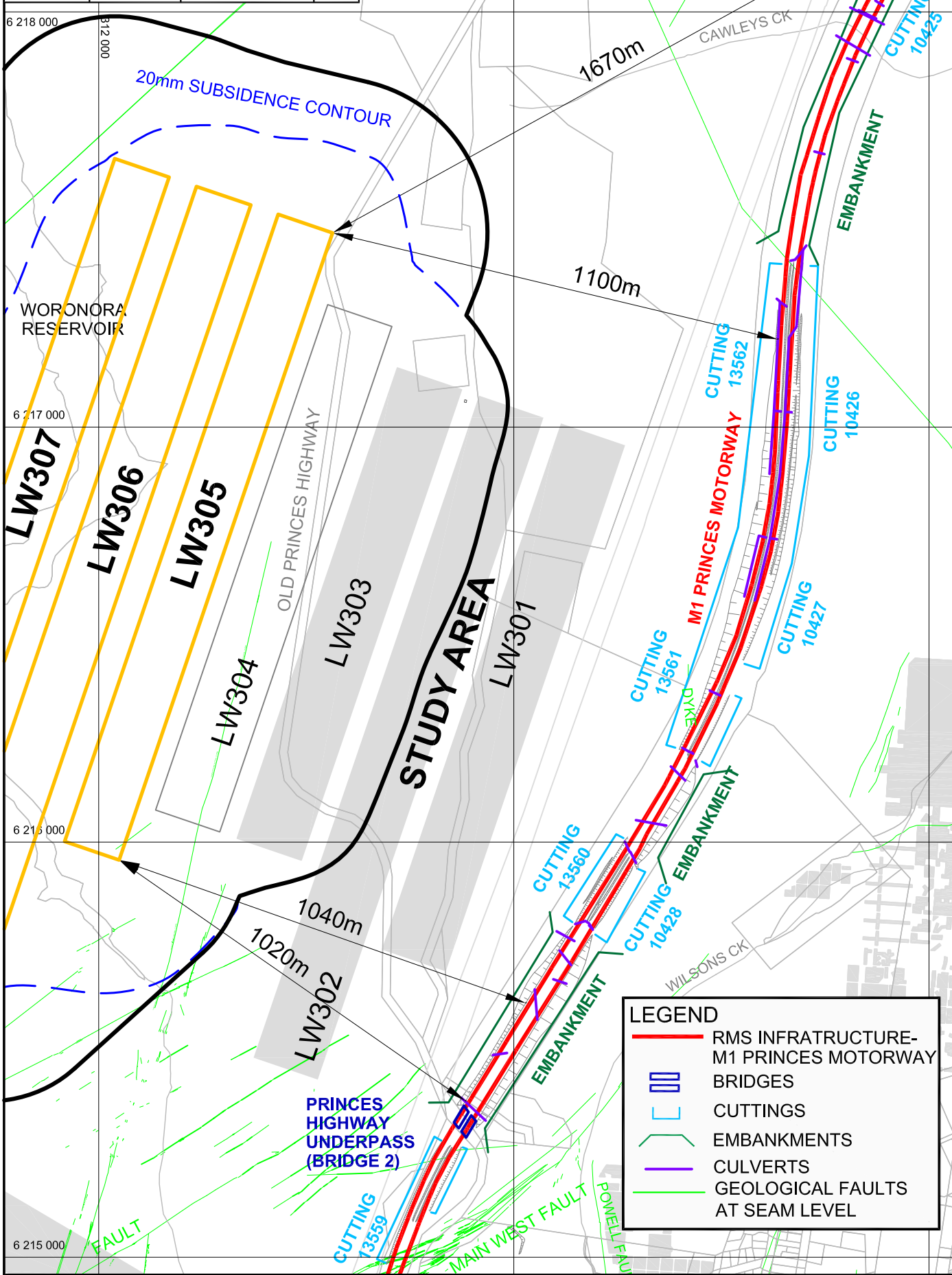

**LEGEND**

- RMS INFRASTRUCTURE- M1 PRINCES MOTORWAY
- BRIDGES
- CUTTINGS
- EMBANKMENTS
- CULVERTS
- GEOLOGICAL FAULTS AT SEAM LEVEL

APPENDIX 8

BUILT FEATURES MANAGEMENT PLAN - SUBSIDENCE IMPACT REGISTER

Metropolitan Coal – LW305-307 Built Features Management Plan – Roads and Maritime Services		
Revision No. BFMP_TFNSW-R01-D		
Document ID: Built Features Management Plan - TFNSW		



**Built Features Management Plan – Subsidence Impact Register  
Assessment Form**

**Date:**

**Observer (Name and position):**

**Register Number (i.e. Number 1, 2, etc.):**

**Longwall Number and Chainage:**

**Location of Observed Impact:**  
(Examples: location of culvert, include GPS co-ordinates and a sketch)

**Description of Observed Impact:**  
(Examples: nature and extent of impact - cracks in road etc any relevant information, attach photographs)

**Person Notified:**      Manager - Technical Services     

**Description of Photographs:**

<b>Actions Required:</b>	Contingency Plan Initiated	<input type="checkbox"/>	
	Incident Notification	<input type="checkbox"/>	
	Safety Measures/Public Management Plan Requirements	<input type="checkbox"/>	Safety

**Management or Contingency Measures Implemented:**

**Effectiveness of Management or Contingency Measures:**

APPENDIX 9

CONTINGENCY PLAN PROCEDURE AND DECISION TREES

Metropolitan Coal – Built Features Management Plan – Roads and Maritime Services		
Revision No. BFMP_TFNSW-R01-D	ME-TSE-MNP-0088	
Document ID: Built Features Management Plan - TFNSW		

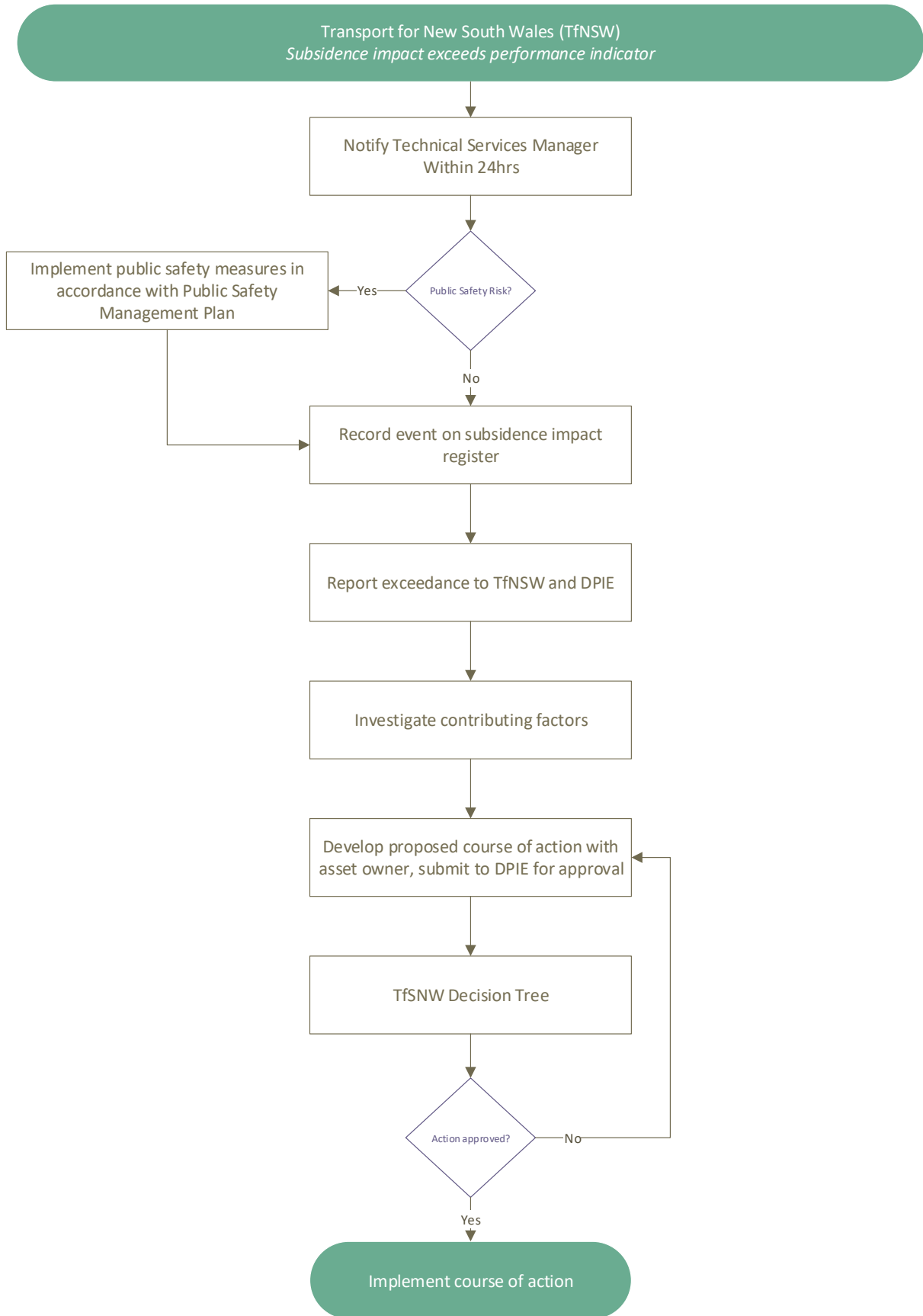

Metropolitan Coal – LW305-307 Built Features Management Plan – Roads and Maritime Services		
Revision No. BFMP_TFNSW-R01-D	ME-TSE-MNP-0088	
Document ID: Built Features Management Plan - TFNSW		

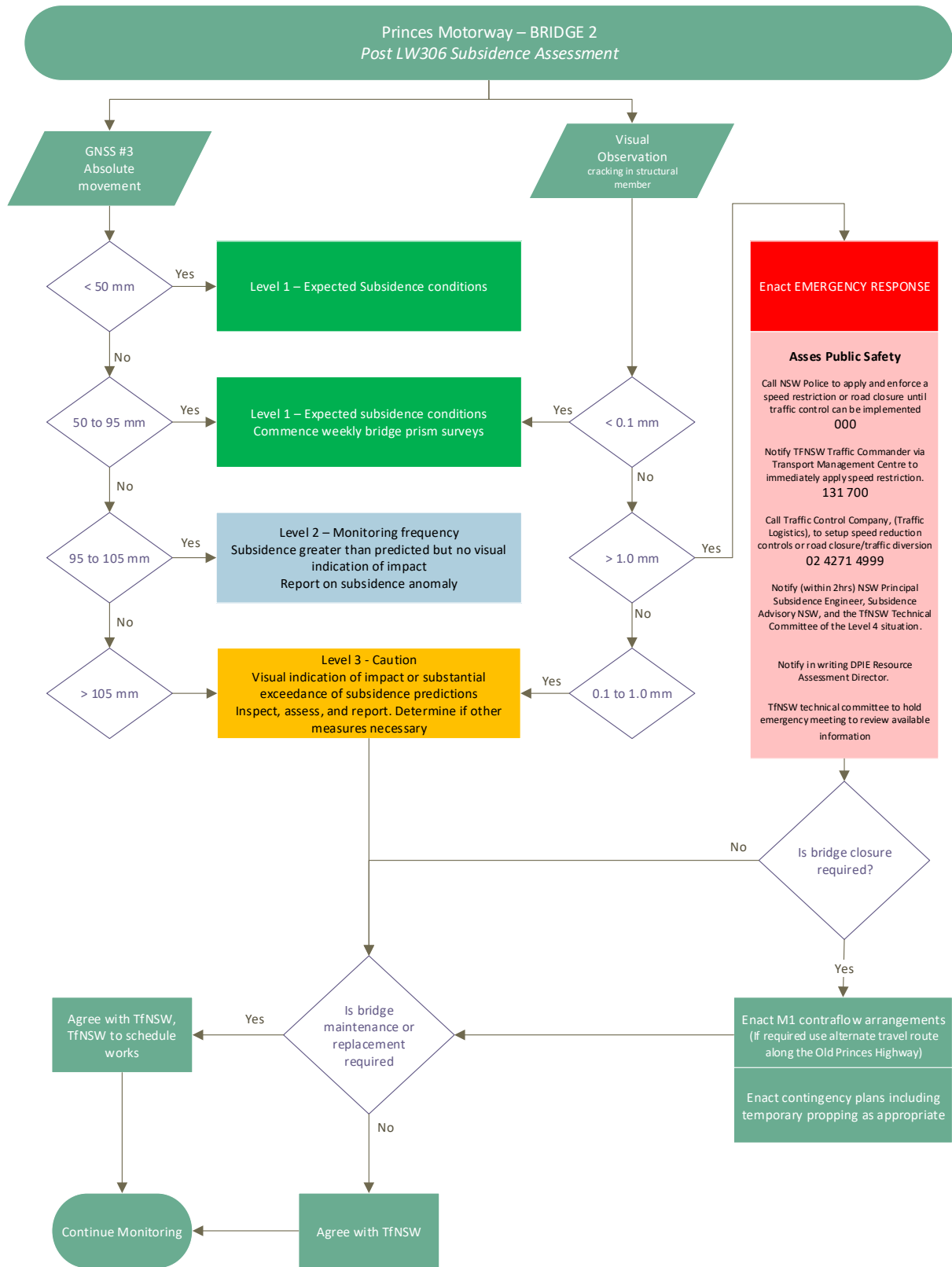

Metropolitan Coal – LW305-307 Built Features Management Plan – Roads and Maritime Services		
Revision No. BFMP_TFNSW-R01-D	ME-TSE-MNP-0088	
Document ID: Built Features Management Plan - TFNSW		

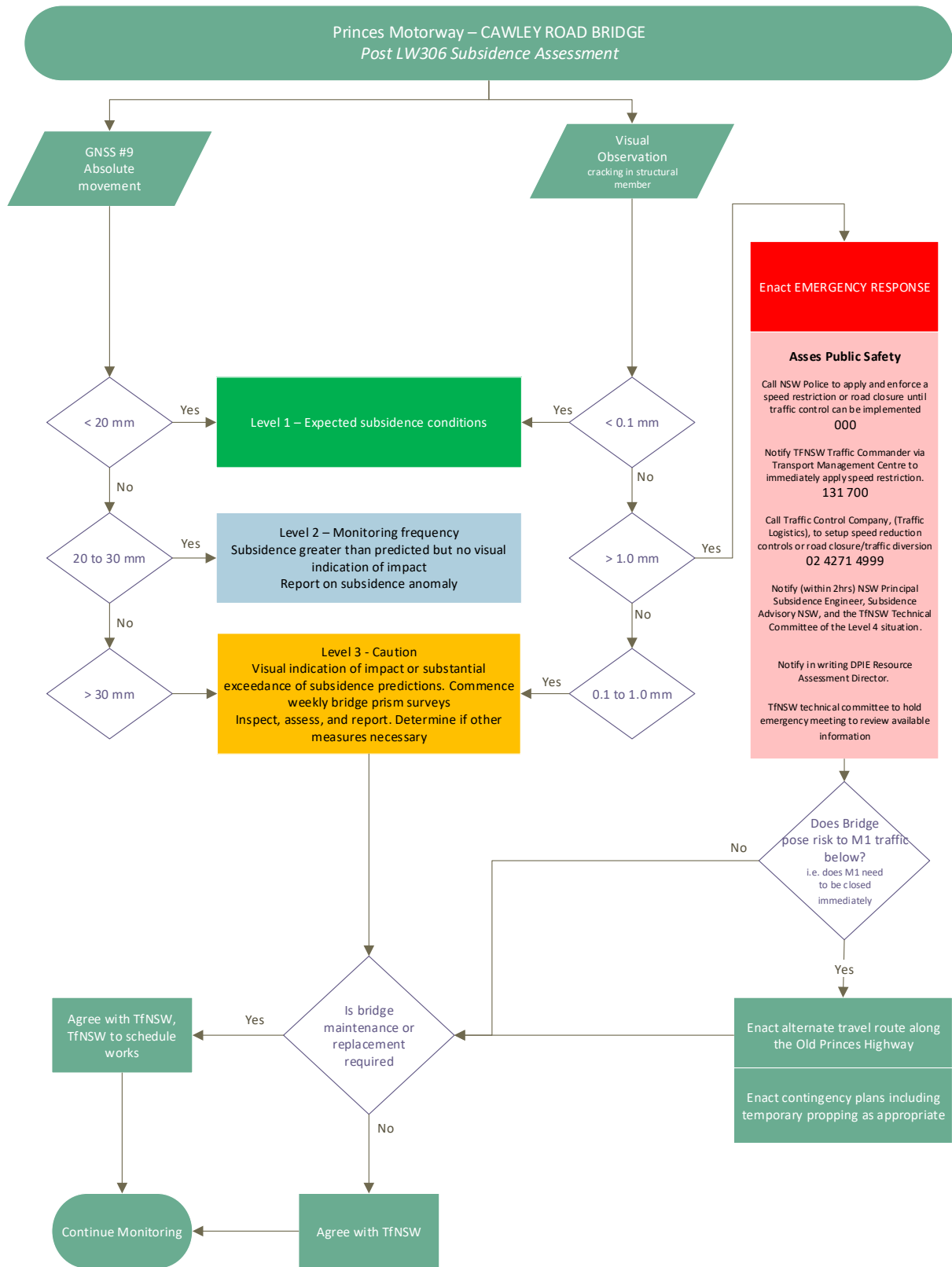

Metropolitan Coal – LW305-307 Built Features Management Plan – Roads and Maritime Services		
Revision No. BFMP_TFNSW-R01-D	ME-TSE-MNP-0088	
Document ID: Built Features Management Plan - TFNSW		

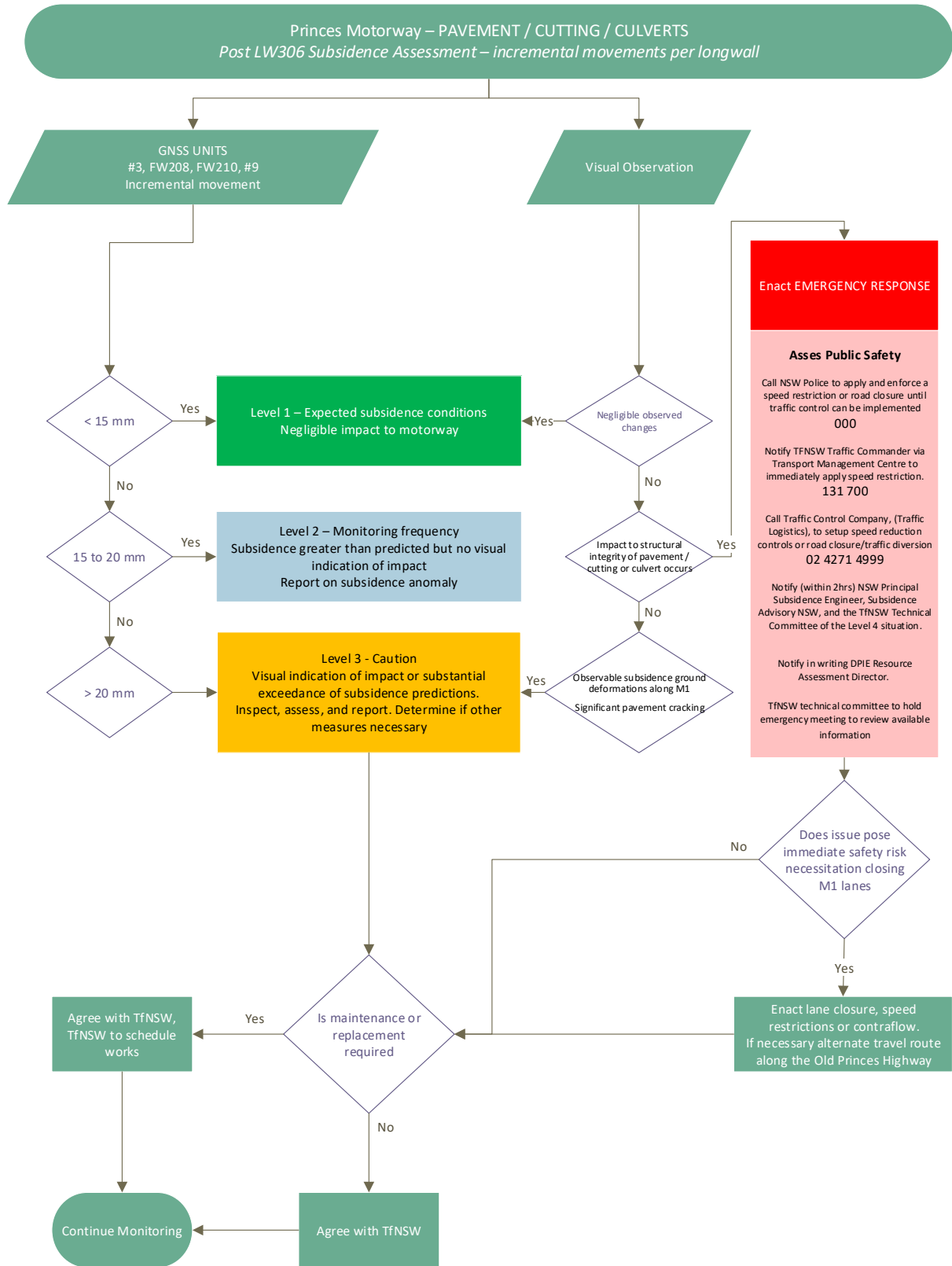

Metropolitan Coal – LW305-307 Built Features Management Plan – Roads and Maritime Services		
Revision No. BFMP_TFNSW-R01-D	ME-TSE-MNP-0088	
Document ID: Built Features Management Plan - TFNSW		

APPENDIX 10

AECOM MEMORANDUM – METROPOLITAN COAL LW304 BRIDGE 2 TRIGGER REVIEW

Metropolitan Coal – LW305-307 Built Features Management Plan – Roads and Maritime Services		
Revision No. BFMP_TFNSW-R01-D	ME-TSE-MNP-0088	
Document ID: Built Features Management Plan - TFNSW		

Memorandum

To	Dick Lee Shoy	Page	9
CC	Technical Committee		
Subject	Metropolitan Coal – LW304 – Bridge 2 Trigger review		
From	Henk Buys		
File/Ref No.	60546746	Date	20 Aug 2019

1.0 Introduction

1.1 Background

Metropolitan Coal has been extracting coal west of the M1 Princes Motorway at Helensburgh and has to date extracted longwalls LW301 to 303. Extraction of LW304 has now commenced. The location of the M1 Princes Motorway and the longwalls, extracted from Ref 1, is shown in Figure 1.

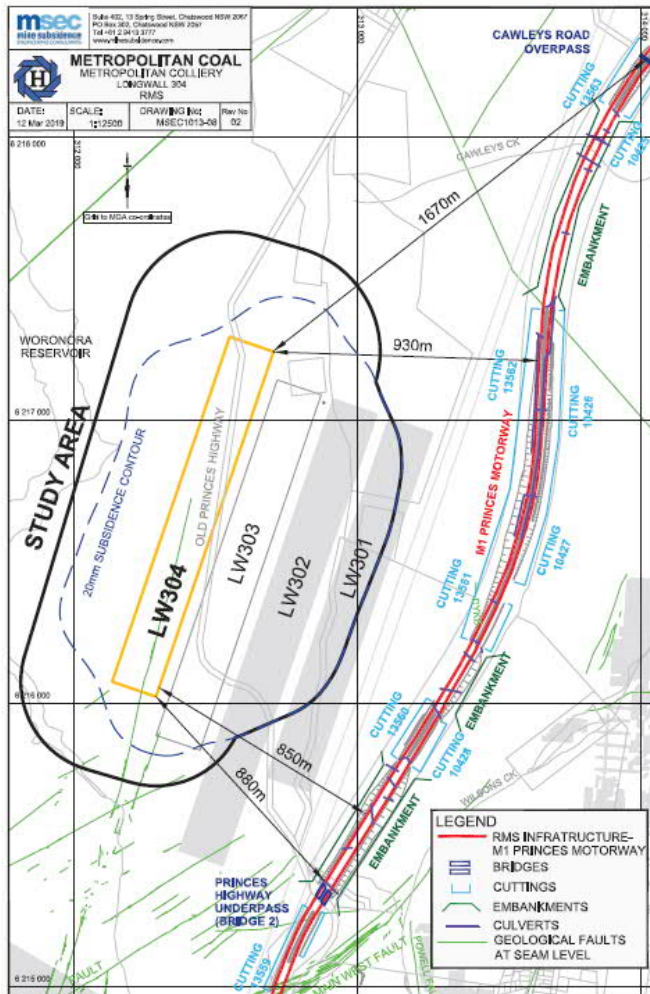

Figure 1: Metropolitan Coal longwall layout

The Built Features Management Plans (BFMPs) for successive longwalls have included Trigger Action Response Plans (TARPs) which describe responses at various trigger levels for RMS infrastructure potentially impacted by the mining operation. For Highway Underpass 2 (Bridge 2), the TARP requires that weekly surveys commence at the bridge once absolute horizontal ground movements at the bridge exceed 30mm, based on ground survey data.

During the course of mining high accuracy GNSS units were installed at the Ausgrid transmission line towers. These units provide continuous, real time positional data to accuracies significantly greater than the periodic manual surveys. The Technical Committee considered locating a GNSS unit at the bridge, but the idea was discarded due to the high vandalism risk in the area. The Technical Committee therefore determined that using the GNSS unit closest to Bridge 2 to trigger local 3D bridge surveys should be assessed. An appropriate trigger level should also be assessed.

## 1.2 Purpose

The purpose of this memo is to:

- Provide an analysis of the GNSS data
- Make recommendations for their inclusion in the monitoring plan and TARP
- Determine appropriate trigger levels and responses for these units.

## 2.0 Review of GNSS data

### 2.1 GNSS unit locations and longwall finish lines

The Ausgrid transmission line towers run parallel to the longwalls and the GNSS units are located on the bases of these towers. Figure 2 shows the location of the GNSS units, the longwalls, the M1 and Bridge 2.

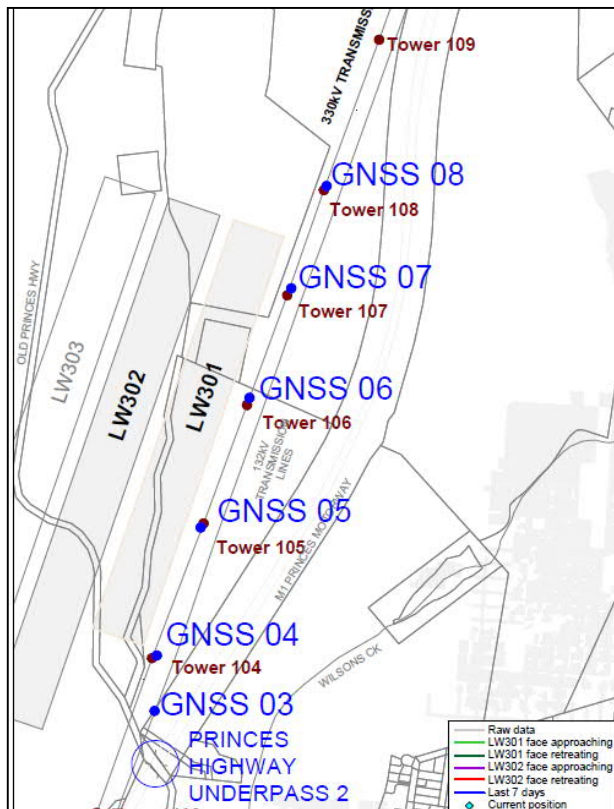

**Figure 2: GNSS unit locations**

**2.2 Analysis methodology**

**2.2.1 General**

Northings and Eastings are approximately parallel and transverse to the longwall respectively and hence in these analyses Northings and Eastings have been used to approximate parallel and transverse movement without adjustment to the data.

Ground movements parallel to and transverse to the longwalls differ for the various GNSS units. This is generally due to the location of the unit in relation to the longwall finish line. Those units beyond the finish line will generally have subdued transverse movements due to the absence of a goaf to move into. The direction of longitudinal ground movements reverses at units above the longwall finish line as the longwall passes the unit. Recorded movements along Northings and Eastings have therefore been assessed separately.

**2.2.2 Determine GNSS units for analysis**

The ground movement plots for north-south and east-west movements differ and these have therefore been assessed separately.

The incremental ground movement data provided by MSEC is presented in Figure 3 below. The plot is for total movement and does not differentiate between longitudinal and transverse movement. However, the plot does indicate that incremental ground movements generally fall within a reasonably narrow band for distances greater than 300m for GNSS03 and GNSS04.

Ground movements at GNSS05, GNSS06, GNSS08 and GNSS09 are not consistent with the above units as they are located too far north for full development of the subsidence bowl.

Also, because of their locations north of the longwall finish lines GNSS05, GNSS06, GNSS08 and GNSS09 have a significantly larger transverse component than GNSS03 and GNSS04.

Hence the GNSS units used for further assessment are GNSS03 and GNSS04.

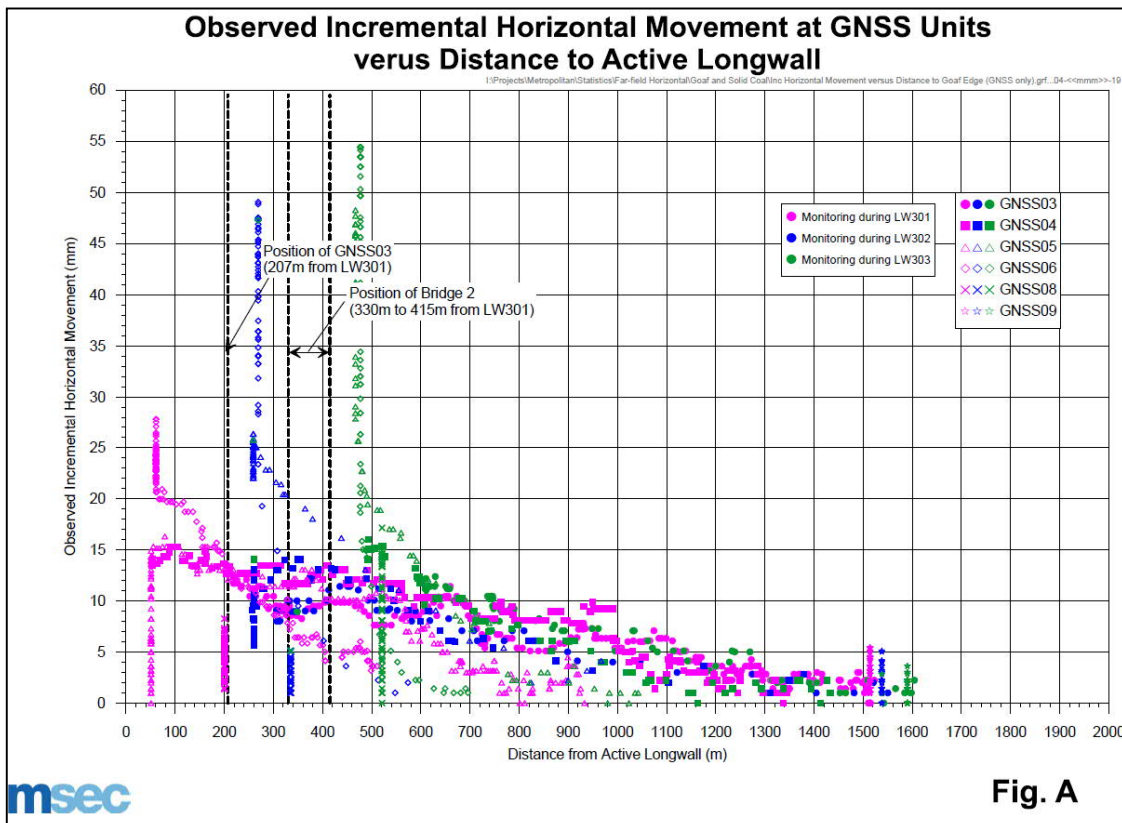
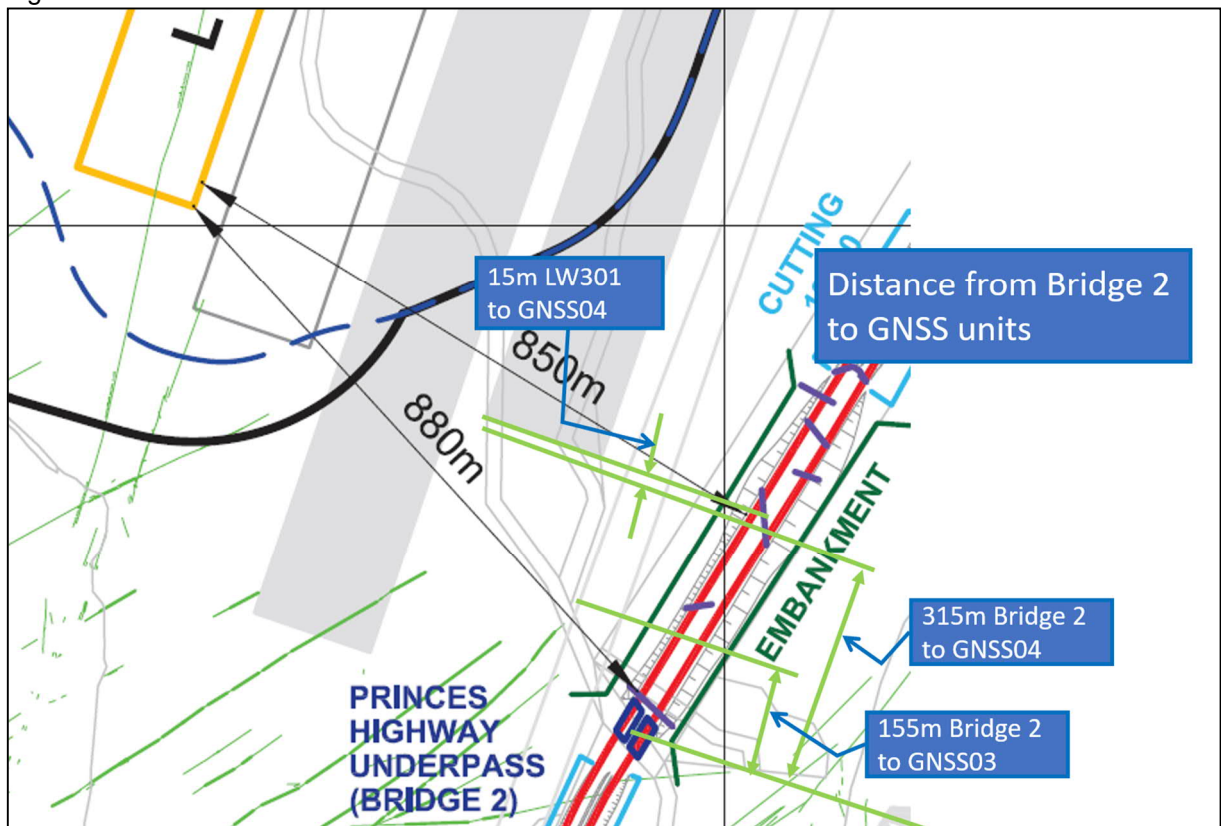

**Figure 3: Incremental ground movement data**

## 2.2.3 Estimate absolute ground movement at Bridge2

GNSS03 and GNSS04 were used to estimate likely ground movements at Bridge 2, adopting the following process separately for each unit:

- Determine the offset from the finish line to Bridge 2 for each longwall (L1). These offsets are presented in
- Figure 4.

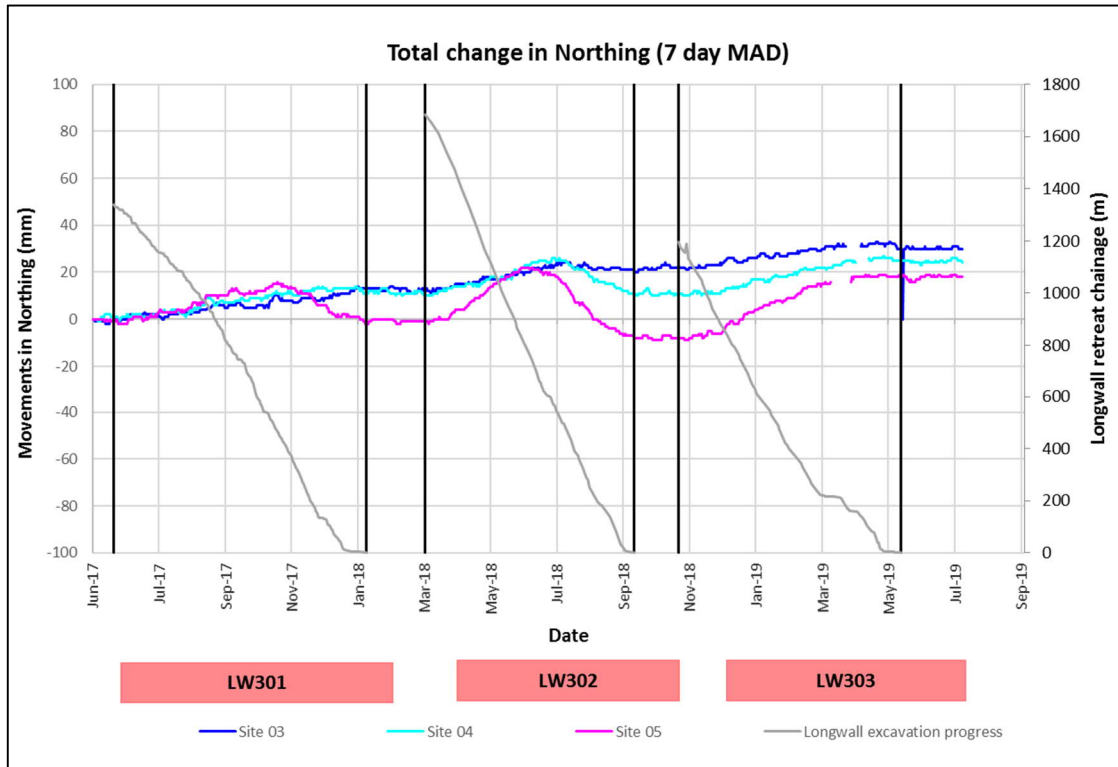

**Figure 4: Distance from Bridge 2 to GNSS units**

- Determine the longwall chainage a distance L1 north of the GNSS unit. This is the equivalent chainage of the longwall finish line for the bridge.
- Read off the ground movement from the longwall commencement line to this chainage. This is the incremental ground movement at the bridge due to this longwall.
- Repeat the above step for successive longwalls.
- Add the incremental movements from each longwall to estimate the total movement at the bridge due to extraction of LW301, LW302 and LW303.

## 2.3 Results of analysis

GNSS movement data for units GNSS03 and GNSS04, provided by MSEC have been plotted against time together with the longwall retreat chainage in Figure 5 (Northings) and Figure 6 (Eastings). It can be seen that there is generally good agreement between GNSS03 and GNSS04 movements.



**Figure 5: Movements – Northing at Sites GNSS03, GNSS04 and GNSS05**

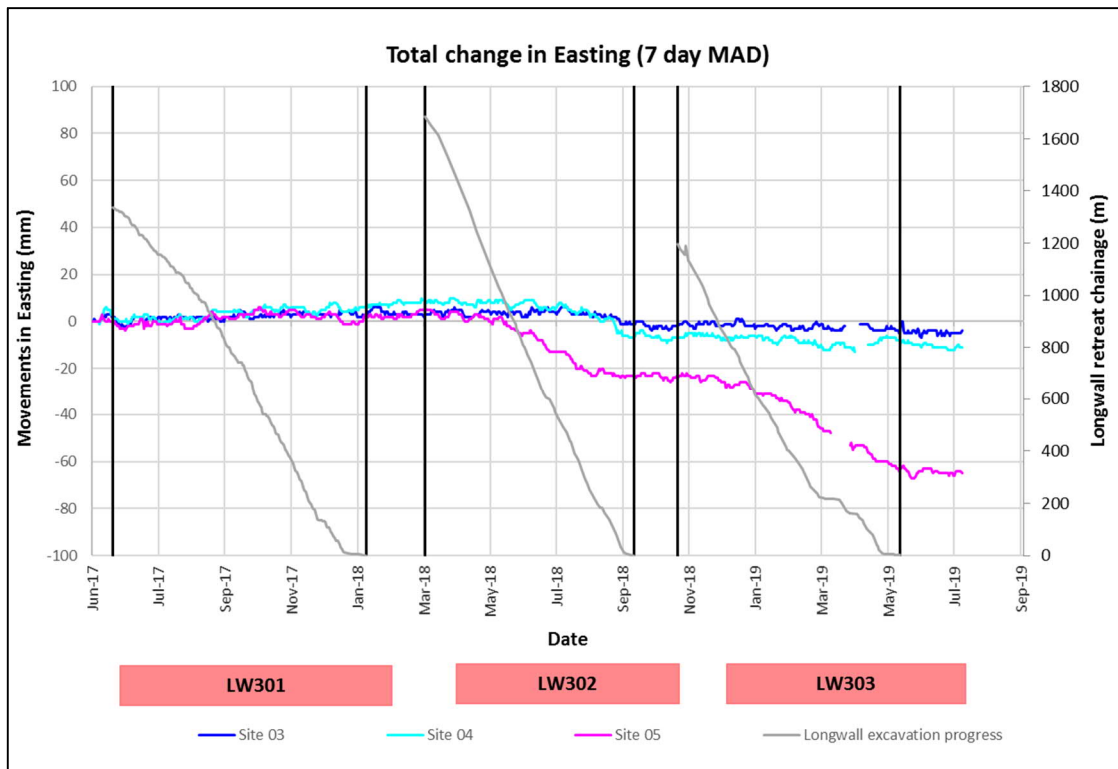

**Figure 6: Movements in Easting at Sites GNSS03, GNSS04 and GNSS05**

Movements at the bridge have been estimated using these plots and the longwall offset of 330m from the bridge. The results of these assessments are presented in Table 1.

**Table 1: Estimated absolute ground movements at Bridge 2 from assessment of GNSS03 and GNSS04 (northings)**

LW	Distance L1 (m)		Estimated Movements Northing (mm)		Estimated Movements Easting (mm)	
	GNSS03	GNSS04	GNSS 3	GNSS 4	GNSS 3	GNSS 4
LW301	155	315	10	11	3	5
LW302	155	315	6	9	2	1
LW303	155	315	9	8	2	3
Total estimated movement =			25	28	7	9

Averaging the above estimated ground movements at the bridge gives total estimated movements of 26.5mm (north) and 8mm (west) or a total estimated movement of 27mm to date. This is less than the current trigger level.

## 2.4 FBG monitoring data

The latest FBG monitoring graphs (30-07-2019), attached, have been reviewed. The graphs indicate seasonal movement variations in both the north-south and east-west directions of up to 5mm. There is also an underlying movement trend towards the north and east in the data, although both the seasonal and trend movements are very small. As the northern abutment is the reference line, the trend data imply compression in the north-south direction and possibly westward movement of the north abutment relative to the south abutment. Both are counter to the total movements recorded by the GNSS units and expected movements. Hence it is considered that there is insufficient movement to provide reliable trend data that can be used to establish a relationship between GNSS and FBG monitoring data.

## 3.0 Bridge survey triggers

### 3.1 General

Currently absolute ground movement in excess of 30mm at Bridge 2 triggers the requirement for a relative 3D survey of the bridge. These movements have been exceeded at GNSS03 but the above assessment indicates that this trigger has not yet been exceeded at the bridge. However, it could be exceeded during extraction of LW304.

Maximum recorded total movements to date at GNSS03 are 33mm and maximum estimated total movements at the bridge are 26.5mm. Using this data and simple proportionality, ground movements at the bridge can be expected reach 30mm when recorded ground movements at GNSS03 reach 37mm.

In addition, with no more than 1mm or 2mm of potential trend movement in the FBGs over a period of two years, it is considered that the 30mm trigger at the bridge is too sensitive, and that an increase to 40mm would be appropriate. This would be the equivalent of 50mm ground movement at GNSS03, and it is proposed that this value be adopted as the value that would trigger a relative 3D survey at the bridge.

It should be noted that the GNSS triggers have not been set because of concerns regarding structural movements at the bridges, but simply to trigger a relative 3D survey at the bridges. The relative 3D surveys are considered appropriate at these triggers for the following reasons:

- At Bridge 2:
  - The FBGs essentially measure movements in the deck and not in the substructure. The relative 3D terrestrial survey will provide additional monitoring points particularly at ground level and the piers.
  - The survey provides additional data to assess movements at the low movement levels recorded by the FBGs at Bridge 2.
- At Cawley Road
  - There are no other relative 3D bridge monitoring systems in place.

## 3.2 New Triggers – Bridge 2

Whilst it is not possible to establish a relationship between the two monitoring data sets, they both provide very accurate movement data, the GNSS units absolute movement, and the FBGs relative movement, and it is considered that these data sets should be used to provide triggers for carrying out a relative 3D survey of the bridge.

### GNSS03 trigger

Trigger: It is proposed to set a new trigger of 50mm total movement at GNSS03.

Action: If trigger is exceeded, carry out review of FBG monitoring data and carry out relative 3D survey of the bridge. The 3D survey would be carried out to verify the FBG monitoring data, and would therefore be carried out regardless of FBG monitoring results. If the relative 3D survey verifies the FBG monitoring data, review of the FBG data can be used to determine the need for a relative 3D survey for subsequent GNSS03 trigger exceedances.

### FBG Trigger

Trigger: The need for a relative 3D survey will be determined by the Bridge Engineer based on review of the FBG monitoring data.

Action: Carry out a relative 3D survey if required by the Bridge Engineer. Bridge Engineer to assess survey results and determine any actions required.

## 3.3 New Triggers – Cawley Road Bridge

For consistency in the GNSS triggers, the trigger at the Cawley Road will also be modified in line with the trigger at Bridge 2. As GNSS09 is located at rather than some distance from the bridge, the trigger would be set at 40mm absolute movement.

### GNSS09 trigger

Trigger: It is proposed to set a new trigger of 40mm total movement at GNSS09.

Action: If trigger is exceeded, carry out review of FBG monitoring data and carry out relative 3D survey of the bridge. The 3D survey would be carried out to record the amount of relative movement that has occurred at the bridge. The need for subsequent relative 3D surveys or adjustment of the GNSS09 trigger is to be determined by evaluation of the survey data by the Bridge Engineer and agreement of the Technical Committee.

## 4.0 Conclusions

Estimated absolute ground movements at Bridge 2 to date are 27mm, less than the current trigger level of 30mm.

Ground movements at Bridge 2 during extraction of LW304 can be estimated during mining by continuing the above analysis method using ground movements at GNSS03 and GNSS04.

It is proposed that total ground movements of 50mm at GNSS03 would trigger the requirement for a relative 3D survey.

It should be noted that a proposal to raise the GNSS03 trigger level to 50mm has been made by MSEC through separate, independent analysis and is in line with the changes proposed in this memo.

Incremental ground movements at Bridge 2 during extraction of LW304 are likely to be less than those recorded during LW303 extraction due to the greater distance of this longwall to the west, the shorter finish line and the masking effect of the completed longwalls.

## 5.0 References

1. Metropolitan Coal - Built Features Management Plan Roads and Maritime Services, MSEC, April 2019

## 6.0 Important information about this report

### Client details, scope and reliance

AECOM has prepared this report for the sole use of the Client and for a specific purpose, each as expressly stated in the report. No other party should rely on this report without the prior written consent of AECOM. AECOM undertakes no duty, nor accepts any responsibility, to any third party who may rely upon or use this report. This report has been prepared based on the Client's description of its requirements and AECOM's experience, having regard to assumptions that AECOM can reasonably be expected to make in accordance with sound professional principles. AECOM's findings represent its reasonable judgment within the time and budget context of its commission and utilising the information available to it at the time.

No section or element of this report may be removed, reproduced, electronically stored or transmitted in any form by parties other than those for whom the report has been prepared without the written permission of AECOM. All sections in this report must be viewed in the context of the entire report/document including, without limitation, any assumptions made and disclaimers provided. No section in this report may be excised from the body of the report without AECOM's prior written consent.

Unless explicitly stated in the scope of work, this report does not provide data or advice on the contamination status of the site or adjacent sites.

### Standard of care

AECOM has prepared this report using the standard of reasonable skill, care and diligence required of a consultant performing the same or similar Services. The report should be read in full. No warranty, expressed or implied, is made as to the professional advice included in this report.

### Data sources

AECOM may have relied on information provided by the Client and third parties (Information Providers) to produce this report and arrive at its conclusions. AECOM has not verified information provided by the Information Providers (unless specifically agreed as part of AECOM's scope of work) and we assume no responsibility and make no representations with respect to the adequacy, accuracy or completeness of such information. AECOM assumes no responsibility for inaccuracies in reporting by the Information Providers including, without limitation, by the Client's employees or representatives or for inaccuracies in any other data source whether provided in writing or orally used in preparing or presenting the report.

### Variability in conditions and limitations of data

Subsurface conditions are formed through a variety of natural processes and can be altered by human activities. The behaviour of the ground, groundwater and contaminants are complex and conditions can vary across a particular site. As a result, subsurface conditions cannot be exhaustively defined by investigations at discrete locations. Therefore, it is unlikely that the results and assessments expressed in this report will represent conditions at any location removed from the specific points of sampling. The precision with which conditions can be inferred depends largely on the uniformity of subsurface conditions and on the frequency and method of sampling as constrained by factors such as project budget and time limitations and physical constraints.

Furthermore, subsurface conditions can change over time, which should be considered when interpreting or using the data within this report.

## **Verification of opinions and recommendations**

The opinions and recommendations in this report apply to the proposed development and the site existing at the time of our investigation and cannot necessarily apply to changes in the proposed development or site changes of which AECOM is not aware and has not had the opportunity to evaluate. Our recommendations should be considered to be preliminary and subject to verification during project implementation. If conditions encountered at the site are subsequently found to differ significantly from those anticipated, AECOM must be notified and be provided with an opportunity to review the recommendations.

## **Henk Buys**

Technical Director- Ground Engineering  
D +61 2 8934 0127 M +61 448 997 500  
[Henk.Buys@aecom.com](mailto:Henk.Buys@aecom.com)

## **AECOM**

Level 21, 420 George Street, Sydney, NSW 2000  
PO Box Q410, QVB PO, Sydney, NSW, 1230  
T +61 2 8934 0000 F +61 2 8934 0001  
[www.aecom.com](http://www.aecom.com)